

# **DX190W**

Operation and Maintenance Manual

K1024512E

Serial Number 5001 and Up

September 2006

*DOOSAN* reserves the right to improve our products in a continuing process to provide the best possible product to the market place. These improvements can be implemented at any time with no obligation to change materials on previously sold products. It is recommended that consumers periodically contact their distributors for recent documentation on purchased equipment.

This documentation may include attachments and optional equipment that is not available in your machine's package. Please call your distributor for additional items that you may require.

Illustrations used throughout this manual are used only as a representation of the actual piece of equipment, and may vary from the actual item.



# Table of Contents

<b>Safety</b> .....	<b>1-1</b>
To the Operator of a Excavator.....	1-1
Location of Safety Labels.....	1-5
Summary of Safety Precautions for Lifting in Digging Mode.....	1-13
Unauthorized Modifications.....	1-14
General Hazard Information.....	1-14
Before Starting Engine .....	1-23
Machine Operation.....	1-27
Maintenance .....	1-33
Battery.....	1-41
Towing .....	1-43
Shipping and Transportation.....	1-44
Excavator Rated Lift Capacity Tables.....	1-45
<b>Operating Controls</b> .....	<b>2-1</b>
Component Locations .....	2-4
Operator's Area.....	2-6
Operational Controls and Panels .....	2-8
Instrument Panel.....	2-26
Multifunction Gauge and Graphic Information .....	2-32
Mode Selector Buttons.....	2-38
Setting Main Menu .....	2-40
Flow Control.....	2-49
Operation Selection Display.....	2-51
Heater and Air Conditioner Control Panel.....	2-53
Stereo .....	2-59
Miscellaneous Electrical Devices.....	2-61
Seat Adjustment.....	2-63

Ceiling Cover .....	2-67
Front Windows .....	2-68
Door Side Latch .....	2-70
Cabin Storage Compartments .....	2-71
Ashtray .....	2-71
Sun Visor .....	2-72
Hanger .....	2-72
Cup Holder.....	2-73
Door Window Holder.....	2-73
Emergency Glass Breaking Tool .....	2-73
Miscellaneous Access Covers and Doors.....	2-74
Swing Lock Pin and Mechanism .....	2-76
Wheel Chocks.....	2-76
<b>Operation.....</b>	<b>3-1</b>
To Handle a New Excavator .....	3-1
Starting and Stopping the Engine .....	3-2
Safety Lever.....	3-14
Travel.....	3-15
Operating Instructions.....	3-23
Operating Precautions .....	3-30
Parking Excavator.....	3-35
Towing Procedure.....	3-36
Hydraulic Breaker .....	3-38
Adjusting the Pump Flow .....	3-43
Operating Techniques.....	3-46
Operation Under Unusual Conditions .....	3-48
<b>Inspection, Maintenance and Adjustment.....</b>	<b>4-1</b>
Preventive Maintenance .....	4-1
Preliminary Work Machine Setup for Maintenance.....	4-4
Table of Recommended Lubricants .....	4-6
Fluid Capacities .....	4-8

Lubrication and Service Chart.....	4-8
Maintenance Intervals.....	4-12
10 Hour / Daily Service .....	4-15
50 Hour / Weekly Service .....	4-25
250 Hour Service .....	4-29
500 Hour / 3 Month Service .....	4-35
1,000 Hour / 6 Month Service .....	4-46
2,000 Hour / Yearly Service .....	4-53
4,000 Hour / Biennial Service .....	4-61
12,000 Hour / Six Year Service.....	4-62
Air-Conditioning System .....	4-63
Inspection of Bolt And Nut Tightening Elements.....	4-64
Bucket.....	4-72
Electrical System .....	4-75
Engine Cooling System.....	4-79
Fuel Transfer Pump (Option) .....	4-81
Handling of Accumulator.....	4-84
Tires and Wheels .....	4-86
Venting and Priming Hydraulic System.....	4-91
Maintenance in Special Conditions.....	4-94
Long Term Storage .....	4-95
<b>Transportation .....</b>	<b>5-1</b>
Short Distance Self-powered Travel .....	5-2
Trailer Loading/Unloading Procedures .....	5-3
<b>Troubleshooting .....</b>	<b>6-1</b>
Engine.....	6-1
Hydraulic System .....	6-3
Swing System .....	6-4
Electrical System .....	6-4
Travel System .....	6-5
Steering.....	6-6

Brakes.....	6-7
<b>Specification .....</b>	<b>7-1</b>
Specification.....	7-1
Overall Dimensions.....	7-3
Working Range .....	7-5
<b>Index .....</b>	<b>8-1</b>

# Safety

## TO THE OPERATOR OF A EXCAVATOR

---



---

**Unsafe use of the excavator could lead to serious injury or death. Operating procedures, maintenance and equipment practices or traveling or shipping methods that do not follow the safety guidelines on the following pages could cause serious, potentially fatal injuries or extensive damage to the machine or nearby property.**

---

Please respect the importance of taking responsibility for your own safety, and that of other people who may be affected by your actions.

The safety information on the following pages is organized into the following sections:

1. "Location of Safety Labels" on page 1-5
2. "Summary of Safety Precautions for Lifting in Digging Mode" on page 1-13
3. "Unauthorized Modifications" on page 1-14
4. "General Hazard Information" on page 1-14
5. "Before Starting Engine" on page 1-23
6. "Machine Operation" on page 1-27
7. "Maintenance" on page 1-33
8. "Battery" on page 1-41
9. "Towing" on page 1-43
10. "Shipping and Transportation" on page 1-44
11. "Excavator Rated Lift Capacity Tables" on page 1-45



## **WARNING!**

---

Improper operation and maintenance of this machine can be hazardous and could result in serious injury or death.

Operator and maintenance personnel should read this manual thoroughly before beginning operation or maintenance.

Keep this manual in the storage compartment to the rear of the operator's seat, and have all personnel involved in working on the machine read the manual periodically.

Some actions involved in operation and maintenance of the machine can cause a serious accident, if they are not done in a manner described in this manual.

The procedures and precautions given in this manual apply only to intended uses of the machine.

If you use your machine for any unintended uses that are not specifically prohibited, you must be sure that it is safe for any others. In no event should you or others engage in prohibited uses or actions as described in this manual.

*DOOSAN* delivers machines that comply with all applicable regulations and standards of the country to which it has been shipped. If this machine has been purchased in another country or purchased from someone in another country, it may lack certain safety devices and specifications that are necessary for use in your country. If there is any question about whether your product complies with the applicable standards and regulations of your country, consult *DOOSAN* or your *DOOSAN* distributor before operating the machine.

---

---

 **SAFETY ALERT SYMBOL** 

---

**Be Prepared - Get to Know All Operating and Safety Instructions.**

**This is the Safety Alert Symbol. Wherever it appears in this manual or on safety signs on the machine you should be alert to the potential for personal injury or accidents. Always observe safety precautions and follow recommended procedures.**

---

## **Learn the Signal Words Used with the Safety Alert Symbol**

The words "CAUTION," "Warning," and "DANGER" used throughout this manual and on decals on the machine indicate degree of risk of hazards or unsafe practices. All three degrees of risk indicate that safety is involved. Observe precautions indicated whenever you see the Safety Alert "Triangle," no matter which signal word appears next to the "Exclamation Point" symbol.

---

 **CAUTION!**

---

**This word is used on safety messages and safety labels and indicates potential of a hazardous situation that, if not avoided, could result in minor or moderate injury. It may also be used to alert against a generally unsafe practice.**

---

 **WARNING!**

---

**This word is used on safety messages and safety labels and indicates potential of a hazardous situation that, if not avoided, could result in serious injury or death. It may also be used to alert against a highly unsafe practice.**

---

 **DANGER!**

---

**This word is used on safety messages and safety labels and indicates an imminent hazard of a situation that, if not avoided, is very likely to cause death or extremely serious injury. It may also be used to alert against equipment that may explode or detonate if handled or treated carelessly.**

---

Safety precautions are described in SAFETY from page 1-5 on.

*DOOSAN* cannot predict every circumstance that might involve a potential hazard in operation and maintenance. Therefore the safety messages in this manual and on the machine may not include all possible safety precautions. If any procedures or actions not specifically recommended or allowed in this manual are used, you must be sure that you and others can do such procedures and actions safely and without damaging the machine. If you are unsure about the safety of some procedures, contact a *DOOSAN* distributor.

# LOCATION OF SAFETY LABELS

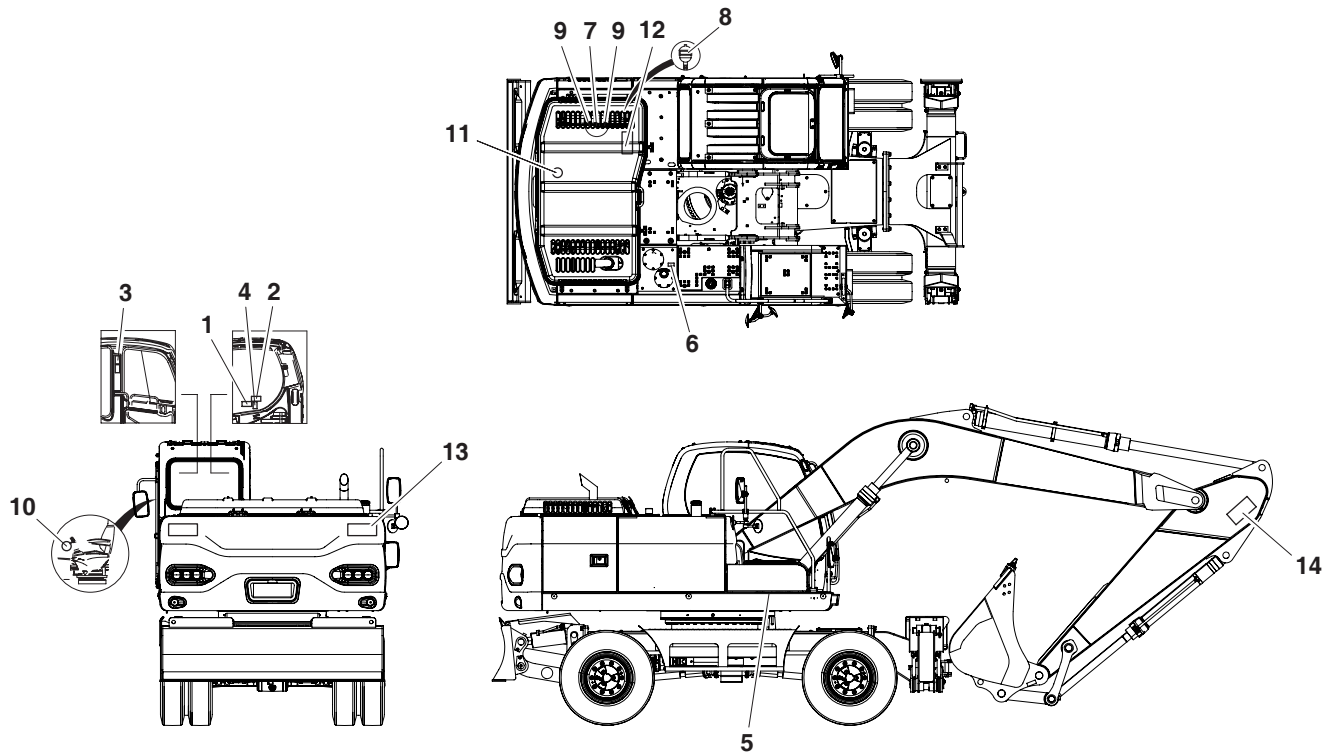

FG008689

**Figure 1**

There are several specific warning signs on this machine. The exact location of hazards and the description of the hazards are reviewed in this section.



Please become familiarized with all warning signs.

Make sure that all of the warning signs are legible. Clean the warning signs or replace the warning signs if you cannot read the words. Replace the illustrations if the illustrations are not visible. When you clean the warning signs, use a cloth, water and soap. Do not use solvent, gasoline, or other harsh chemicals to clean the safety signs.



Solvents, gasoline, or other harsh chemicals could loosen the adhesive that secures the warning sign. Loose adhesive will allow the warning sign to fall off.

Replace any safety sign that is damaged, or missing. If a safety sign is attached to a part that is replaced, install a safety sign on the replacement part.

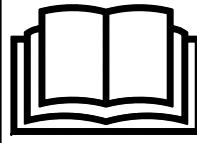
# 1. Warnings for Operation, Inspection and Maintenance (190-00742, 190-00092)

 <b>WARNING</b>	  190-00092
<ul style="list-style-type: none"> <li>• AVOID DEATH OR SERIOUS INJURY. - READ AND UNDERSTAND OPERATION MANUAL AND SAFETY LABELS prior to operating this machine.</li> <li>• Never get in under the machine while it is being jacked up with boom and arm.</li> <li>• Sound the horn to alert the people nearby before operating, and make sure that all persons are clear of area.</li> <li>• Controls may be changed for attachments or operator preference. Try control pattern before operating.</li> </ul>	
190-00742	FG007284

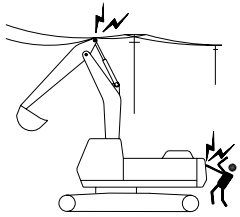
# 2. Warnings for High Voltage (190-00689, 190-00096)

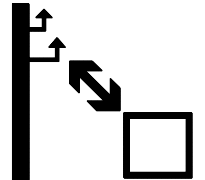
	 <b>DANGER</b>	  190-00096						
	<p>SERIOUS INJURY OR DEATH BY ELECTROUTION can occur if machine or attachments are not a safe distance from electrical power lines.</p> <table border="1"> <thead> <tr> <th>Line voltage</th> <th>Safe Distance</th> </tr> </thead> <tbody> <tr> <td>6.6 kv</td> <td>At least 3m(10ft)</td> </tr> <tr> <td>66.6 kv</td> <td>At least 5m(16ft)</td> </tr> <tr> <td>275.0 kv</td> <td>At least 10m(33ft)</td> </tr> </tbody> </table>		Line voltage	Safe Distance	6.6 kv	At least 3m(10ft)	66.6 kv	At least 5m(16ft)
Line voltage	Safe Distance							
6.6 kv	At least 3m(10ft)							
66.6 kv	At least 5m(16ft)							
275.0 kv	At least 10m(33ft)							
	190-00689	ARO1090L						

### 3. Warnings When Opening a Front Window (2190-3388, 190-00093)

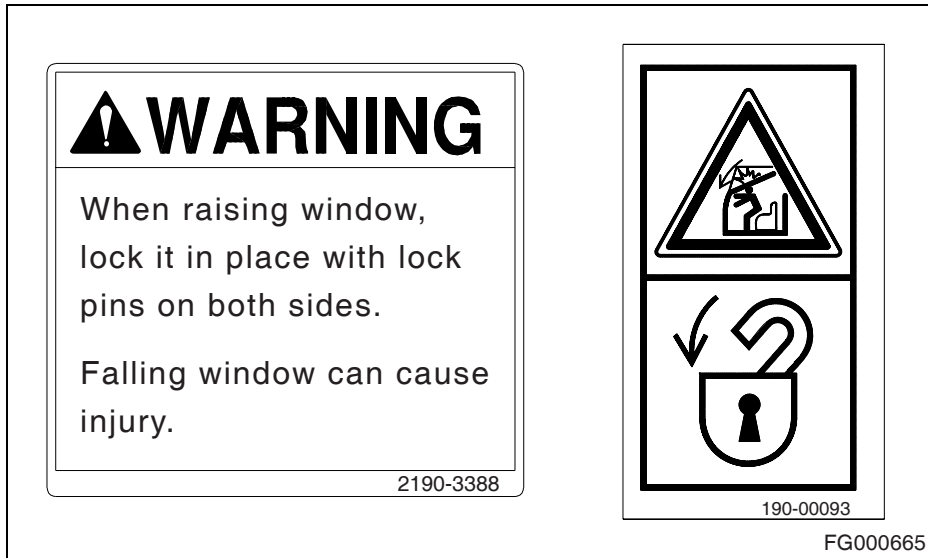

### 4. Warnings for Leaving Operator's Seat (190-00693, 190-00094)

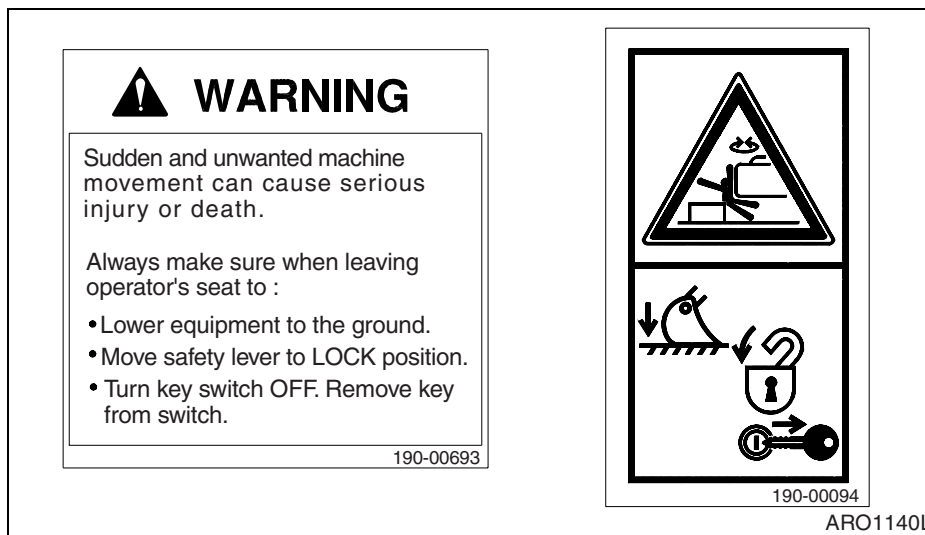

## 5. Warnings for Batteries Maintenance (2190-2533A, 190-00100)

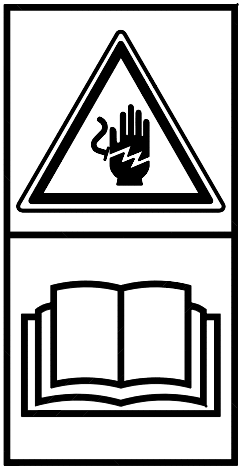
<p style="text-align: center;"><b>▲ DANGER</b></p> <ul style="list-style-type: none"><li>• Battery fumes can explode. Keep sparks and flames away from batteries.</li><li>• Always avoid storing metals like tools or flammable materials around or on the batteries. Explosion or fire can be caused by shortcircuiting batteries.</li><li>• Sulfuric acid in battery is poisonous. It is strong enough burn skin, eat holes in clothing, and cause blindness if splashed eyes.</li></ul> <p>If you spill acid on yourself;</p> <ol style="list-style-type: none"><li>1. Flush your skin with water.</li><li>2. Apply baking soda or lime to help neutralize the acid.</li><li>3. Flush your eyes with water for 10-15 minutes.</li></ol> <p style="text-align: center;">Get medical attention immediately.</p> <p style="text-align: right;">2190-2533A</p>	 <p style="text-align: center;">190-00100</p>
---	--

ARO1150L

## 6. Warnings for High Temperature Hydraulic Oil (190-00691, 190-00097)

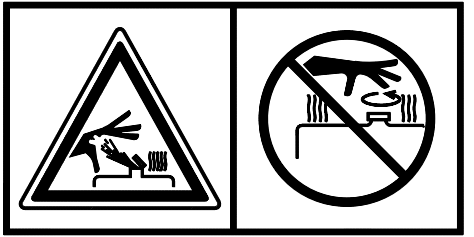
<p style="text-align: center;"><b>▲ WARNING</b></p> <p style="text-align: center;"><b>HYDRAULIC OIL</b></p> <p>HOT OIL CAN CAUSE INJURY OR BLINDNESS.</p> <p>To prevent hot oil from spurting out:</p> <ul style="list-style-type: none"><li>• Turn engine off</li><li>• Allow oil to cool</li><li>• Slowly loosen cap to relieve pressure</li></ul> <p style="text-align: right;">190-00691</p>	 <p style="text-align: center;">190-00097</p>
--	---

ARO1160L

## 7. Warnings for Hot Coolant (190-00692, 190-00097)

<p><b>⚠ WARNING</b></p> <p>HOT COOLANT CAN CAUSE INJURY OR BLINDNESS.</p> <p>Never loosen or open radiator cap when coolant is hot and under pressure.</p> <p>To open cap, stop engine, wait until radiator is cool. Then loosen cap slowly to relieve the pressure.</p> <p>190-00692</p>	 <p>190-00097</p>
---	---

ARO1170L

## 8. Warnings for Handling an Accumulator (190-00703, 190-00099)

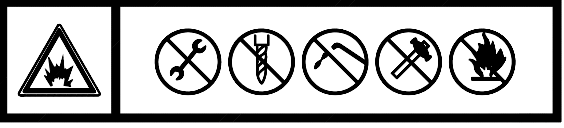
<p><b>⚠ WARNING</b></p> <p>EXPLOSION HAZARD</p> <ul style="list-style-type: none"><li>• Keep away from flame.</li><li>• Do not weld on, or drill into the accumulator.</li></ul> <p>190-00703</p>	 <p>190-00099</p>
---	---

ARO1180L

**9. Warnings for Rotating Parts  
(190-00694, 190-00095, 190-00557)**

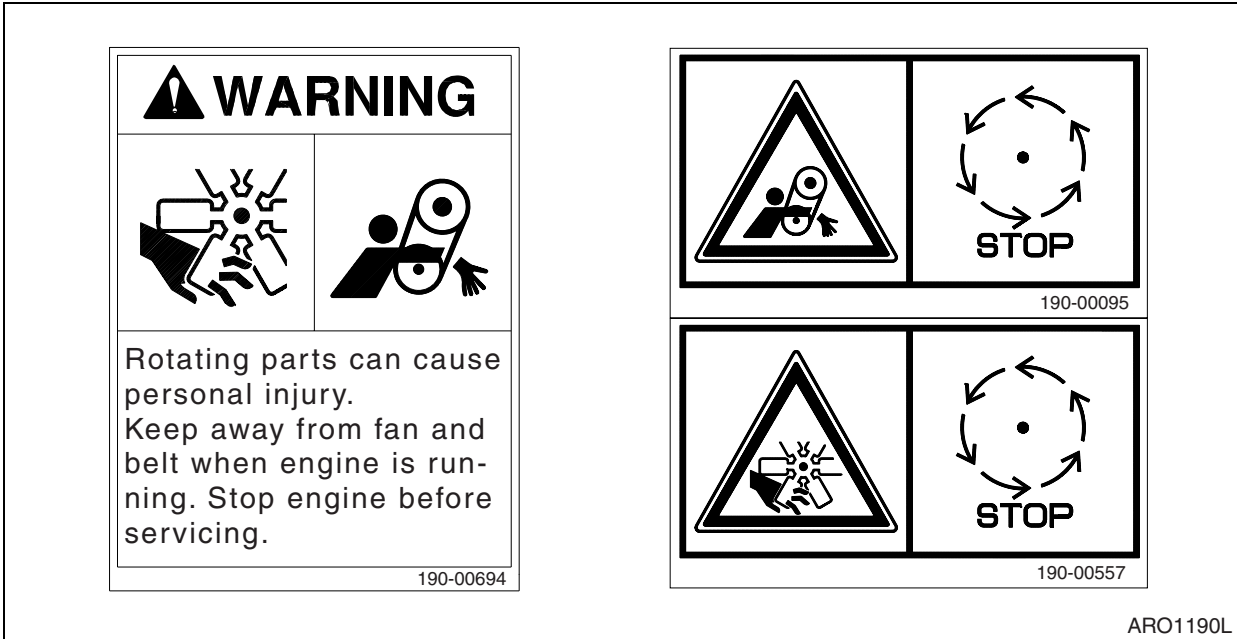

**10. Warning Tag - Used When Inspection  
and Maintenance (190-00695,  
190-00098)**

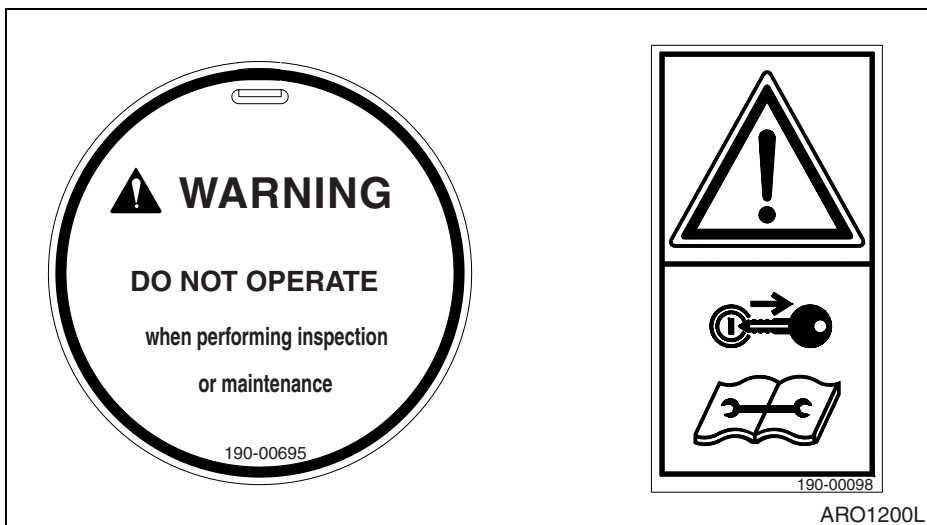

**11. Warning for a Hot Surface  
(190-00648A)**

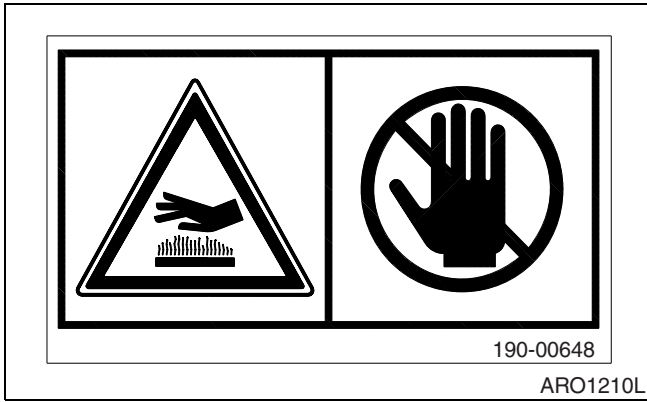

**12. Caution for Hood (190-00522)**

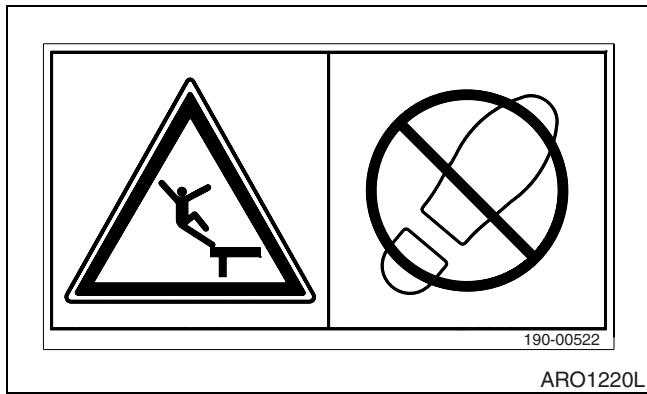

**13. Keep Out of the Swing Area  
(2190-3379, K1008571)**

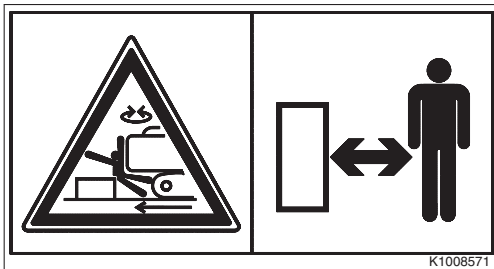

FG000180

**14. Warnings for Front Attachments  
(190-00652)**



# SUMMARY OF SAFETY PRECAUTIONS FOR LIFTING IN DIGGING MODE

---

## **DANGER!**

---

Unsafe use of the excavator while making rated lifts could cause serious, potentially fatal injuries or extensive damage to the machine or nearby property. Do not let anyone operate the machine unless they've been properly trained and understand the information in the Operation and Maintenance Manual.

---

To lift safely while in Digging Mode, the following items must be evaluated by the operator and the work site crew.

- Condition of ground support.
- Excavator configuration and attachments.
- Weight, lifting height and lifting radius.
- Safe rigging of the load.
- Proper handling of the suspended load.

Tag lines on opposite sides of the load can be very helpful in keeping a suspended load secure, if they are anchored safely to control points on the ground.

---

## **WARNING!**

---

**NEVER** wrap a tag line around your hands or body.

**NEVER** rely on tag lines or make rated lifts when wind gusts are more than 48.3 km/h (30 MPH). Be prepared for any type of wind gust when working with loads that have a large surface area.

---

Always engage the "Digging Mode" control on the Instrument Panel before using the excavator for lifting work.

---

## **WARNING!**

---

If you need more information or have any questions or concerns about safe operating procedures or working the excavator correctly in a particular application or in the specific conditions of your individual operating environment, please consult your local *DOOSAN* representative.

---

# UNAUTHORIZED MODIFICATIONS

Any modification made without authorization or written approval from *DOOSAN* can create a safety hazard, for which the machine owner must be held responsible.

For safety's sake, replace all OEM parts with the correct authorized or genuine *DOOSAN* part. For example, not taking the time to replace fasteners, bolts or nuts with the correct replacement parts could lead to a condition in which the safety of critical assemblies is dangerously compromised.

## GENERAL HAZARD INFORMATION

### Safety Rules

Only trained and authorized personnel can operate and maintain the machine.

Follow all safety rules, precautions and instructions when operating or performing maintenance on the machine.

Do not operate the machine if you are not feeling well, if you are taking medication that makes you feel sleepy, if you have been drinking, or if you are suffering from emotional problems. These problems will interfere with your sense of judgement in emergencies and may cause accidents.

When working with another operator or with a person on work site traffic duty, be sure that all personnel know the nature of the work and understand all hand signals that are to be used.

Always observe strictly any other rules related to safety.

### Safety Features

Be sure that all guards and covers are installed in their proper position. Have guards and covers repaired immediately if damaged.

Be sure that you understand the method of use of safety features such as safety lock lever and the seat belt, and use them properly.

Never remove any safety features. Always keep them in good operating condition.

Failure to use safety features according to the instructions in the Operation and Maintenance Manual could result in serious bodily injury.

## Inside Operator's Compartment

When entering the operator's compartment, always remove all mud and oil from the soles of your shoes. If you operate the travel pedal with mud or oil stuck to your shoes, your foot may slip and this may cause a serious accident.

After using the ashtray, make sure that any matches or cigarettes are properly extinguished, and be sure to close the ashtray. If the ashtray is left open, there is danger of fire.

Do not stick suction pads to the window glass. Suction pads act as a lens and may cause fire.

Do not leave lighters laying around the operator's compartment. If the temperature inside the operator's compartment becomes high, there is danger that the lighter may explode.

Do not use cellular telephones inside the operator's compartment when driving or operating the machine. There is danger that this may lead to an unexpected accident.

Never bring any dangerous objects such as flammable or explosive items into the operator's cabin.

To ensure safety, do not use the radio or music headphones when operating the machine. There is danger that this may lead to a serious accident.

When operating the machine, do not put your hands or head out of the window.

When standing up from the operator's seat, always place safety lock lever securely in the "LOCK" position. If you accidentally touch the work equipment levers when they are not locked, the machine may suddenly move and cause serious injury or damage.

When leaving the machine, lower the work equipment completely to the ground, set safety lock lever to the "LOCK" position and shut down engine. Use the key to lock all the equipment. Always remove the key and take it with you.

## Clothing and Personal Protective Items

Contain long hair, and avoid loose clothing and jewelry. They can catch on controls or in protruding parts and cause serious injury or death.

Do not wear oily clothes. They are highly flammable.

Full eye protection, a hard hat, safety shoes and gloves may be required at the work site.

While working on the machine, never use inadequate tools. They could break or slip, causing injury, or they may not adequately perform intended functions.

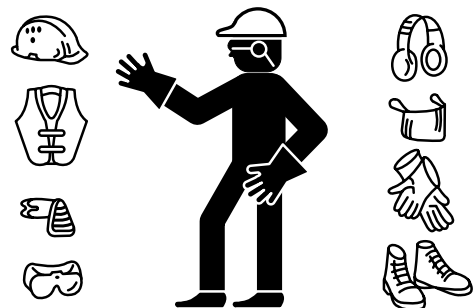

Figure 2

HAOA020L

## Breathing Masks, Ear Protection May Be Required

Do not forget that some risks to your health may not be immediately apparent. Exhaust gases and noise pollution may not be visible, but these hazards can cause disabling or permanent injuries.

**NOTE:** *The equivalent continuous A-weighted sound pressure level at the workstation for this machine is 75 dB (A).*

*Measurement is obtained on a dynamic machine following the procedures and cabin conditions as described in ISO 6396.*

**NOTE:** *The guaranteed sound power level emitted by the machinery for this machine is 101 dB (A).*

*Measurement is obtained on a dynamic machine with the procedures as described in 2000/14/EC.*

## Vibration Level Information

Hands/Arms: The weighted root mean square acceleration to which the hands/arms are subjected, is less than 2.5 m/s<sup>2</sup>.

Whole body: The weighted root mean square acceleration to which the whole body is subjected, is less than 0.5 m/s<sup>2</sup>.

Measurements are obtained on a representative machine, using measuring procedures as described in the following standard: ISO 2631/1, ISO 5349, and SAE J1166.

## Recommendations for Limiting Vibrations

1. Select the right machine, equipment and attachments for a particular application.
2. Replace any damaged seat by a *DOOSAN* genuine part. Keep the seat maintained and adjusted.
  - Adjust the seat and suspension for the weight and size of the operator.
  - Inspect and maintain the suspension and adjustment mechanisms of the seat regularly.
3. Check that the machine is properly maintained.
  - Tire pressure, brakes, steering, linkages, etc.
4. Steer, brake, accelerate, shift gears, move the attachments and load the attachments smoothly.
5. Adjust the machine speed and travel path to reduce the vibration level.
  - Slow down if it is necessary when passing rough terrain.

- Drive around obstacles and excessive rough terrain conditions.
6. Keep the terrain on work sites where the machine is working and traveling in good condition.
    - Remove any large rocks or obstacles.
    - Fill any ditches and holes.
    - Provide machines for and schedule time to maintain the terrain conditions.
  7. Travel over longer distance (e.g. on public roads) at adjusted (medium) speed.
    - Always adjust the speed for preventing bouncing.

## Mounting and Dismounting

Before getting on or off the machine, if there is any oil, grease, or mud on the handrails, steps, wipe it off immediately. Always keep these parts clean. Repair any damage and tighten any loose bolts.

Never jump on or off the machine. In particular, never get on or off a moving machine. These actions may lead to serious injury.

When getting on or off the machine, always face the machine, and maintain three-point contact (both feet and one hand or one foot and both hands) with the handrails and steps to ensure that you support yourself securely.

Never hold any control levers when getting on or off the machine.

Apply the door lock securely. If you grip the handrail inside the door when moving on top of the steps, and the door lock is not applied securely, the door may move and cause you to fall.

Use the points marked by arrows in the diagram when getting on or off the machine.

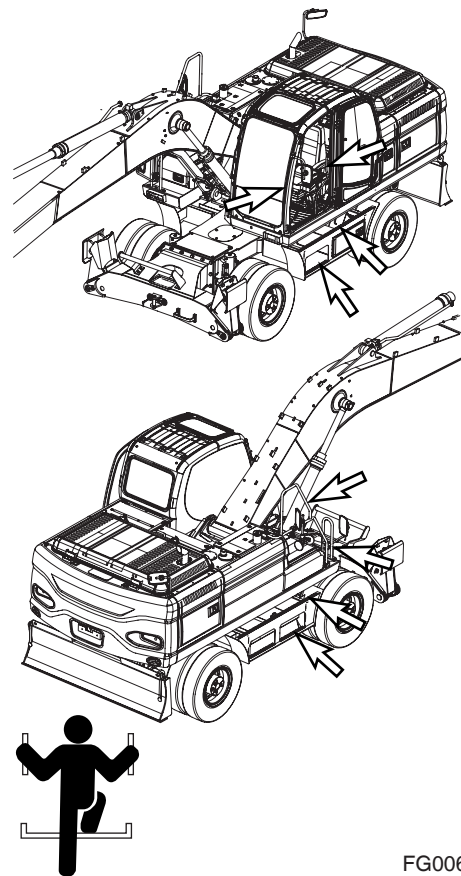

Figure 3

FG006532

## Fuel, Oil and Hydraulic Fluid Fire Hazards

Fuel, oil and antifreeze will catch fire if it is brought close to a flame. Fuel is particularly flammable and can be hazardous.

Always strictly observe the following.

Add fuel, oil, antifreeze and hydraulic fluid to the machine only in a well ventilated area. The machine must be parked with controls, lights and switches turned "OFF." The engine must be "OFF" and any flames, glowing embers, auxiliary heating units or spark causing equipment must be doused, turned "OFF" and/or kept well clear of the machine.

Static electricity can produce dangerous sparks at the fuel filling nozzle. In very cold, dry weather or other conditions that could produce a static discharge, keep the tip of the fuel nozzle in constant contact with the neck of the fuel filling nozzle, to provide a ground.

Keep fuel and other fluid reservoir caps tight and do not start the engine until caps have been secured.

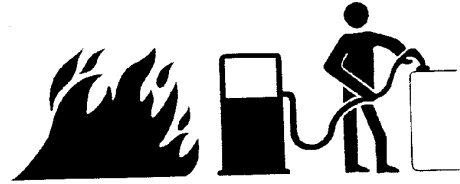

ARO1050S

Figure 4

## Precautions When Handling Fluids at High Temperature

Immediately after operations are stopped, the coolant, engine oil, and hydraulic oil are at high temperature and the radiator and hydraulic tank are still under pressure. Attempting to remove the cap, drain the oil or coolant, or replace the filters may lead to serious burns. Always wait for the temperature to go down, and follow the specified procedures when carrying out these operations.

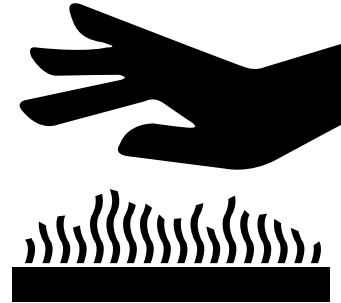

HAOA050L

Figure 5

To prevent hot coolant from spurting out, shut down engine, wait for the coolant to cool, then loosen the cap slowly to relieve the pressure.

To prevent hot oil from spurting out, shut down engine, wait for the oil to cool, then loosen the cap slowly to relieve the pressure.



HAOA060L

Figure 6

## Asbestos Dust Hazard Prevention

Asbestos dust can be HAZARDOUS to your health if it is inhaled. Materials containing asbestos fiber can be present on work site. Breathing air that contains asbestos fiber can ultimately cause serious or fatal lung damage. To prevent lung damage from asbestos fiber, observe following precautions;

- Use a respirator that is approved for use in an asbestos-laden atmosphere.
- Never use compressed air for cleaning.
- Use water for cleaning to keep down the dust.
- Work on the machine or component with the wind at your back whenever possible.
- Always observe any rules and regulations related to the work site and working environment.



ARO1770L

Figure 7

## Injury from Work Equipment

Do not enter or put your hand, arm or any other part of your body between movable parts, such as between the work equipment and cylinders, or between the machine and work equipment.

If the control levers are operated, the clearance between the machine and the work equipment will change and this may lead to serious damage or personal injury.

If going between movable parts is necessary, always position and secure the work equipment so that it cannot move.



HDO1010L

Figure 8

## Fire Extinguisher and First Aid Kit

As a precaution if any injury or fire should occur, always do the following.

- Be sure that fire extinguishers have been provided and read the labels to ensure that you know how to use them. It is recommended that an appropriately sized (2.27 kg [5 lb] or larger) multipurpose "A/B/C" fire extinguisher be mounted in the cabin. Check and service the fire extinguisher at regular intervals and make sure that all work site crew members are adequately trained in its use.
- Provide a first aid kit in the storage compartment and keep another at the work site. Check the kit periodically and make any additions if necessary.
- Know what to do in case of injury from fire.
- Keep emergency numbers for doctor, ambulance service, hospital and fire department near your telephone.

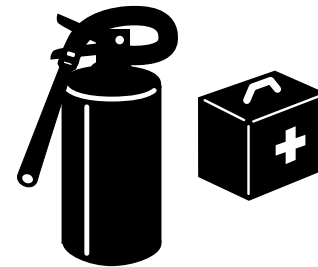

HDO1009L

Figure 9

If the machine catches fire, it may lead to serious personal injury or death. If a fire occurs during operation, escape from the machine as follows;

- Turn the starter switch to the "O" (OFF) position and shut down engine.
- If there is time, use the fire extinguisher to extinguish as much of the fire as possible.
- Use the handrails and steps to escape from the machine.

The above is the basic method for escaping from the machine, but changing the method may be necessary according to the conditions, so carry out practice drills at the work site.

## Protection from Falling or Flying Objects

On work sites where there is danger that falling objects or flying objects may hit the operator's cabin select a guard to match the operating conditions to protect the operator.

Working in mines, tunnels, deep pits or on loose or wet surfaces could produce danger of falling rock or hazardous flying objects. Additional protection for the operator's cabin could be required in the form of a FOPS (Falling Object Protective Structure) or window guards.

Never attempt to alter or modify any type of protective structure reinforcement system, by drilling holes, welding, remounting or relocating fasteners. Any serious impact or damage to the system requires a complete integrity reevaluation. Reinstallation, recertification and/or replacement of the system may be necessary.

Contact your *DOOSAN* distributor for available safety guards and/or recommendations if there is any danger of getting hit by objects that could strike the operator's cabin. Make sure that all other work site crew members are kept well away from the excavator and safe from possible hazards.

For breaker operation, install a front guard and apply a laminated coating sheet to the front glass. Contact your *DOOSAN* distributor for recommendations.

When carrying out demolition or cutting operation, install a front guard and top guard, and apply a laminated coating sheet to the front glass.

When working in mines or quarries where there is danger of falling rock, install FOPS (Falling Objects Protective Structure) and apply a laminated coating sheet to the front glass.

If any glass on the machine is broken, replace it with new glass immediately.

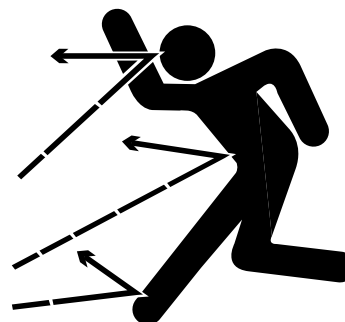

HAOA110L

Figure 10



HAOA100L

Figure 11

## Attachment Precautions

Option kits are available through your dealer. Contact *DOOSAN* for information on available one-way (single-acting) and two-way (double-acting) piping / valving / auxiliary control kits. Because *DOOSAN* cannot anticipate, identify or test all of the attachments that owners may wish to install on their machines, please contact *DOOSAN* for authorization and approval of attachments, and their compatibility with options kits.

## Accumulator

The pilot control system is equipped with an accumulator. For a brief period of time after the engine has been shut down, the accumulator will store a pressure charge that may enable hydraulic controls to be activated. Activation of any controls may enable the selected function to operate under force of gravity.

When performing maintenance on the pilot control system, the hydraulic pressure in the system must be released as describe in "Handling of Accumulator" on page 4-84.

The accumulator is charged with high-pressure nitrogen gas, so it is extremely dangerous if it is handled in the wrong way. Always observe the following precautions;

- Do not drill or make any holes in the accumulator or expose it any flame, fire or heat source.
- Do not weld on the accumulator, or try attaching anything to it.
- When carrying out disassembly or maintenance of the accumulator, or when disposing of the accumulator, the charged gas must be properly released. Contact your *DOOSAN* distributor.
- Wear safety goggles and protective gloves when working on an accumulator. Hydraulic oil under pressure can penetrate the skin and cause serious injuries.

## Indoor Ventilation

Engine exhaust gases can cause fatal accidents, and unconsciousness, loss of alertness, judgement and motor control and serious injury.

Make sure there is adequate ventilation before starting the engine in any enclosed area.

You should also be aware of open windows, doors or ductwork into which exhaust may be carried, or blown by the wind, exposing others to danger.



ARO1770L

Figure 12

## Emergency Exit

This machine is equipped with a glass breaking tool. It is behind the operator seat in the upper right corner of the cabin. This tool can be used in case of an emergency situation that requires the breaking of glass to exit from the operator's cabin. Grip the handle firmly and use the sharp point to break the glass.



**WARNING!**

---

**Protect your eyes when breaking the glass.**

---

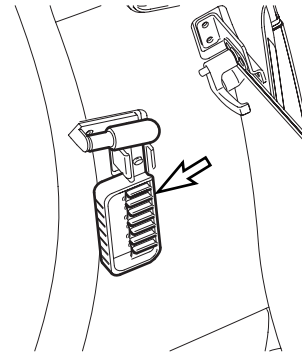

FG000178

**Figure 13**

# BEFORE STARTING ENGINE

## Work Site Precautions

Before starting operations, thoroughly check the area for any unusual conditions that could be dangerous.

Check the terrain and condition of the ground at the work site, and determine the best and safest method of operation.

Make the ground surface as hard and horizontal as possible before carrying out operations. If there is a lot of dust and sand on the work site, spray water before starting operations.

If you need to operate on a street, protect pedestrians and cars by designating a person for work site traffic duty or by erecting fences and posting "No Entry" signs around the work site.

Erect fences, post "No Entry" signs, and take other steps to prevent people from coming close to or entering the work site. If people come close to a moving machine, they may be hit or caught by the machine, and this may lead to serious personal injury or death.

Water lines, gas lines, phone lines and high voltage electrical lines may be buried under the work site. Contact each utility and identify their locations. Be careful not to damage or cut any of these lines.

Check the condition of the river bed, and the depth and flow of the water before operating in water or crossing a river. NEVER be in water that is in excess of the permissible water depth.

Any type of object in the vicinity of the boom could represent a potential hazard, or cause the operator to react suddenly and cause an accident. Use a spotter or signal person working near bridges, phone lines, work site scaffolds, or other obstructions.

Minimum levels of insurance coverage, work permits or certification, physical barriers around the work site or restricted hours of operation may be mandated by governing authorities. There may also be regulations, guidelines, standards or restrictions on equipment that may have to be followed for local requirements. There may also be regulations related to performing certain kinds of work. If there is any question about whether your machine and work site complies with the applicable standards and regulations contact your local authorities and agencies.

Avoid entering soft ground. It will be difficult for the machine to escape.

Avoid operating your machine too close to the edge of cliffs, overhangs, and deep ditches. The ground may be weak in such

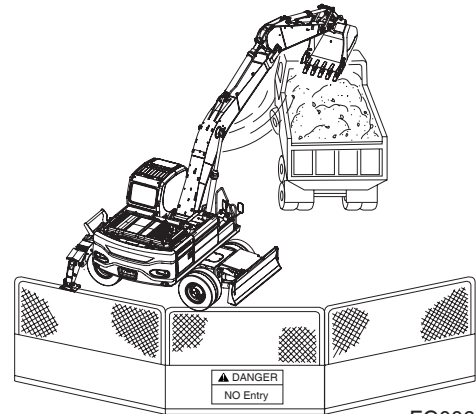

Figure 14

FG006533

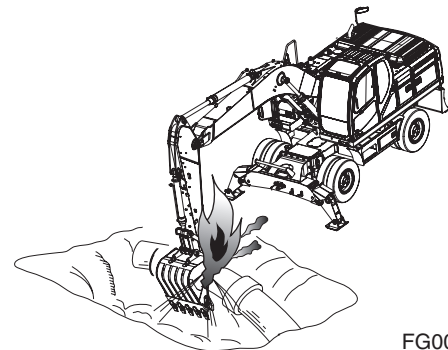

Figure 15

FG006534

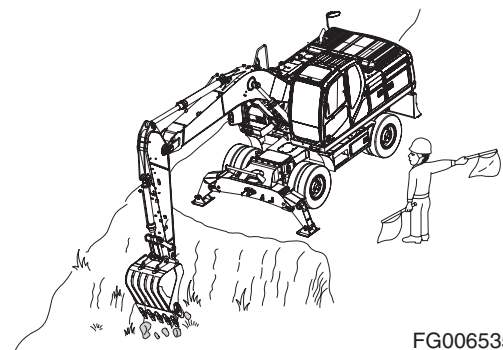

Figure 16

FG006535

areas. If the ground should collapse, the machine could fall or tip over and this could result in serious injury or death.

Remember that the soil after heavy rain, blasting or after earthquakes, is weakened in these areas.

Earth laid on the ground and the soil near ditches is loose. It can collapse under the weight of vibration of your machine and cause your machine to tip over.

Install the head guard (FOPS) if working in areas where there is danger of falling rocks.

## **Checks Before Starting Engine**

Every day before starting the engine for the first time, carry out the following checks. If these checks are not carried out properly, there is danger of serious injury.

Completely remove all wood chips, leaves, grass, paper and other flammable materials accumulated in the engine compartment and around the battery. They could cause a fire. Remove any dirt from the window glass, mirrors, handrails, and steps.

Do not leave tools or spare parts laying around in the operator's compartment. The vibration of the machine when traveling or during operations may cause them to fall and damage or break the control levers or switches. They may also get caught in the gap of the control levers and cause the work equipment to malfunction or move dangerously. This may lead to unexpected accidents.

Check the coolant level, fuel level, and hydraulic tank oil level, and check for clogged air cleaner and damage to the electrical wiring.

Adjust the operator's seat to a position where it is easy to operate the machine, and check the seat belt and mounts for damage and wear.

Check the operation of the gauges and the angle of the mirrors, and check that the safety lever is in "LOCKED" position.

If any abnormalities are found in the above checks, carry out repairs immediately.

## Engine Starting

Walk around your machine before getting in the operator's cabin. Look for evidence of leaking fluid, loose fasteners, misaligned assemblies or any other indications of possible equipment hazard.

All equipment covers and machinery safety guards must be in place, to protect against injury while the machine is being operated.

Look around the work site area for potential hazards, people or property that could be at risk while operation is in progress.

NEVER start the engine if there is any indication that maintenance or service work is in progress, or if a warning tag is attached to controls in the cabin.

A machine that has not been used recently, or is being operated in extremely cold temperatures, could require a warm-up or maintenance service before start-up.

Check gauges and monitor displays for normal operation before starting the engine. Listen for unusual noises and remain alert for other potentially hazardous conditions at the start of the work cycle.

Do not short circuit the starting motor to start the engine. This is not only dangerous, but may also damage the machine.

When starting the engine, sound the horn as an alert.

Start and operate the machine only while seated.

## Before Operating Machine

If checks are not carried out properly after starting the engine, it may result in a delay in discovering abnormalities in the machine, and this may lead to personal injury or damage to the machine.

Carry out the checks in an open area where there are no obstructions. Do not let anyone near the machine when carrying out the checks.

- Check the operating condition of the equipment, and the actuation of the bucket, arm, boom, travel, and swing systems.
- Check the machine for any abnormal noise, vibration, heat, smell, or abnormality with the gauges. Check also for leakage of air, oil, and fuel.
- If any abnormality is found, repair the problem immediately. If the machine is used without repairing the problems, it may lead to unexpected injury or failure.
- Clear all personnel from directly around machine and from the area.
- Clear all obstacles from the machine's path. Beware of hazards.
- Be sure that all windows are clean. Secure the doors and the windows in the open position or in the shut position.
- Adjust the rear view mirrors for best visibility close to the machine. Make sure that the horn, the travel alarm (if equipped), and all other warning devices are working properly.
- Fasten the seat belt securely.
- Warm up the engine and hydraulic oil before operating machine.
- Before moving the machine, check the position of undercarriage. The normal travel position is with idler wheels to the front under the cabin and the drive sprockets to the rear. When the undercarriage is in the reversed position, the travel controls must be operated in opposite directions.

# MACHINE OPERATION

## When Swinging or Changing Direction of Travel

Before operating the machine or the work equipment, always observe the following precautions to prevent serious injury or death.

- Start and operate the machine only while seated.
- When changing the direction of travel from forward to reverse or from reverse to forward, reduce speed early and stop the machine before changing the direction of travel.
- Sound the horn to warn people in the area.
- Check that there is no one in the area around the machine. There are blind spots behind the machine, so if necessary, swing the upper structure to check that there is no one behind the machine before traveling in reverse.
- When operating in areas that may be hazardous or have poor visibility, designate a person to direct work site traffic.
- Ensure that no unauthorized person can come within the turning radius or direction of travel.

Be sure to observe the above precautions even if a travel alarm or mirrors are installed.

## Travel Precautions

Never turn the starting switch to the "O" (OFF) position when traveling. It is dangerous if the engine stops when the machine is traveling. It will be impossible to operate the steering.

Attachment control levers should not be operated while traveling.

Do not change selected travel mode (FAST/SLOW/CLEEP) while traveling.

Fold in work equipment so that the outer end of the boom is as close to the machine as possible, and is 40 ~ 50 cm (16 ~ 20 in) above ground.

Never travel over obstacles or slopes that will cause the machine to tilt severely. Travel around any slope or obstacle that causes the machine to tilt 10 degrees or more to the right or left, or 30 degrees or more from front to rear.

Do not operate the steering suddenly. The work equipment may hit the ground and cause the machine to lose its balance, and this may damage the machine or structures in the area.

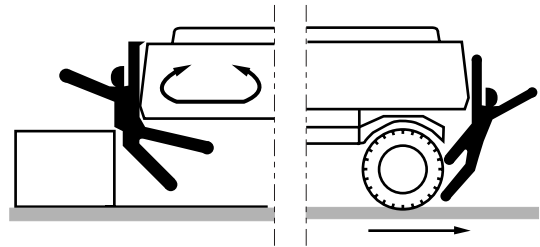

HGB1014L-1

Figure 17

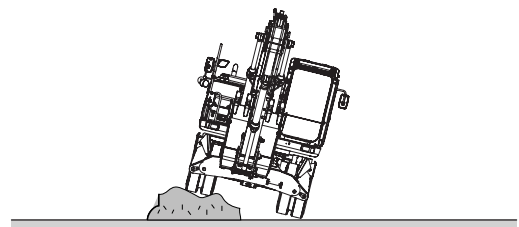
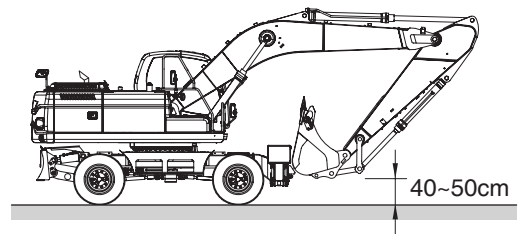

FG006536

Figure 18

When traveling on rough ground, travel at low speed, and avoid sudden changes in direction.

Always keep to the permissible water depth. Permissible water depth is to the center line of the axles.

When traveling over bridges or structures on private land, check first that the bridge or structure can withstand the weight of the machine. When traveling on public roads, check with the local authorities and follow their instructions.

## Traveling on Slopes

Never jump onto a machine that is running away to stop it. There is danger of serious injury.

Traveling on slopes could result in the machine tipping over or slipping.

On hills, banks or slopes, carry the bucket approximately 20 - 30 cm (8 - 12 in) above the ground. In case of an emergency, quickly lower the bucket to the ground to help stop the machine.

Do not travel on grass, fallen leaves, or wet steel plates. Even slight slopes may cause the machine to slip to the side, so travel at low speed and make sure that the machine is always traveling directly up or down the slope.

Avoid changing the direction of travel on a slope. This could result in tipping or side slipping of the machine.

When possible, operate the machine up slopes and down slopes. Avoid operating the machine across the slope, when possible.

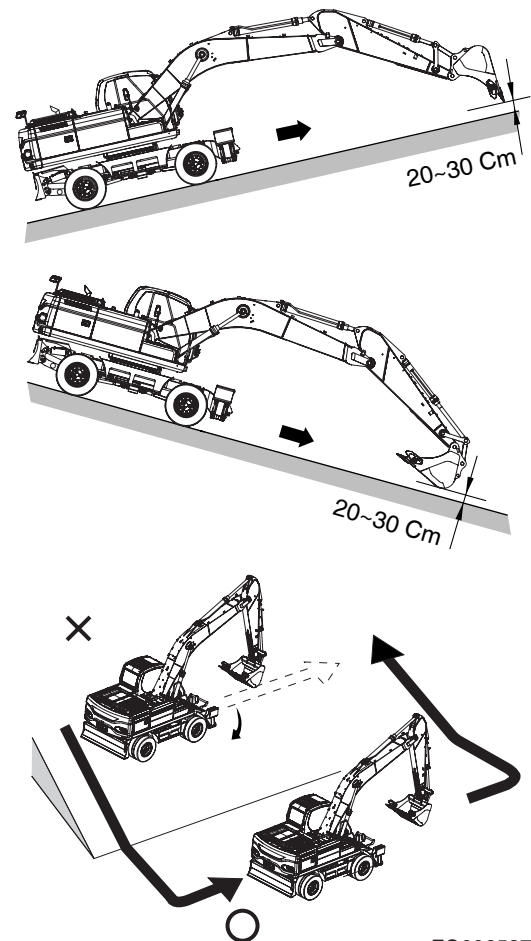

Figure 19

FG006537

## Prohibited Operations

Do not dig the work face under an overhang. This may cause the overhang to collapse and fall on top of the machine.

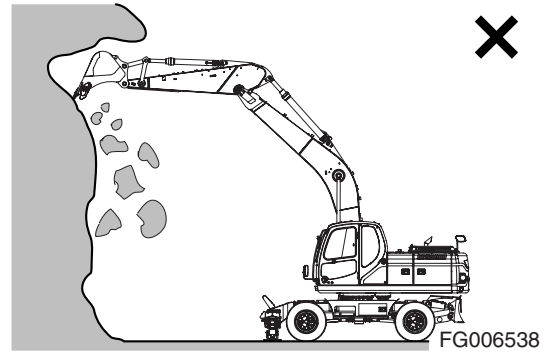

Figure 20

Do not carry out deep digging under the front of the machine. The ground under the machine may collapse and cause the machine to fall.

Working heavy loads over loose, soft ground or uneven, broken terrain can cause dangerous side load conditions and possible tipover and injury. Travel without a load or a balanced load may also be hazardous.

Never rely on lift jacks or other inadequate supports when work is being done. Block tires fore and aft to prevent any movement.

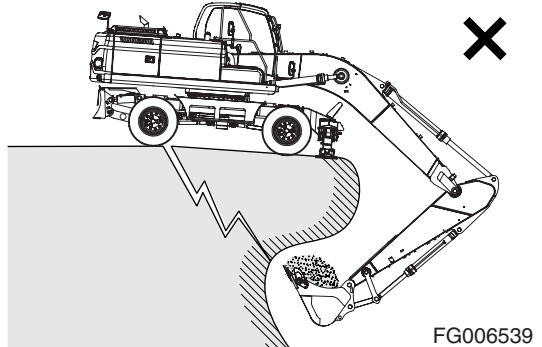

Figure 21

When using the machine, to prevent accidents caused by damage to the work equipment and overturning because of an excessive load, do not use the machine in excess of its ability (in terms of the maximum load and stability determined by the structure of the machine).

When working at the edge of an excavation or on a road shoulder, the machine could tip over, possibly resulting in serious injury or death. Investigate the configuration and ground conditions of the work site beforehand to prevent the machine from falling and to prevent the ground, stockpiles, or banks from collapsing.

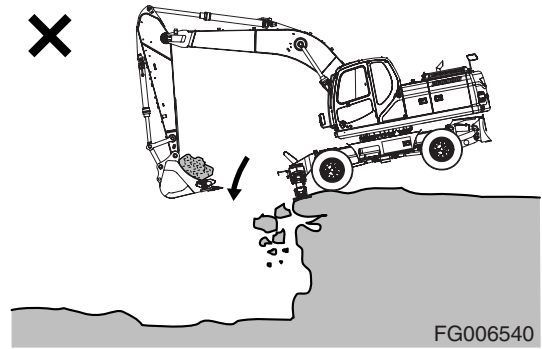

Figure 22

## Precautions for Operation

Be careful not to go close to the edge of a cliff by mistake.

Use the machine only for its main purpose. Using it for other purposes will cause failures.

To ensure an ample view, do as follows:

- When working in dark areas, attach working lights and front lights to the machine. If necessary, set up lighting at the work site.
- Stop operations when the visibility is poor, such as in fog, mist, snow, and rain. Wait for the visibility to improve to a level which causes no problems for the operation.

To avoid hitting the work equipment, always do the following;

- When working in tunnels, on bridges, under electric wires, or when parking the machine or carrying out other operations in places with limited height, be extremely careful not to hit the bucket or other parts.
- To prevent collisions, operate the machine at a safe speed when working in confined spaces, indoors, or in crowded areas.
- Do not pass the bucket over the heads of workers or over the operator's compartment of dump truck.

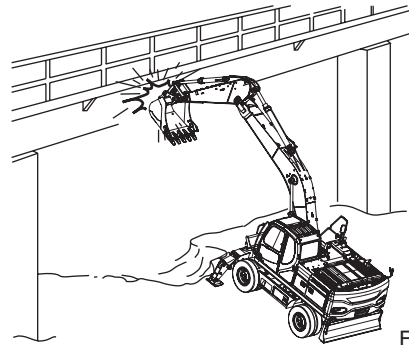

FG006541

Figure 23

## Avoid High Voltage Cables

Serious injury or death can result from contact or proximity to high voltage electric lines. The bucket does not have to make physical contact with power lines for current to be transmitted.

Use a spotter and hand signals to stay away from power lines not clearly visible to the operator.

Voltage	Minimum Safe Distance
6.6 kV	3 m (9' 10")
33.0 kV	4 m (13' 1")
66.0 kV	5 m (16' 5")
154.0 kV	8 m (26' 3")
275.0 kV	10 m (32' 10")

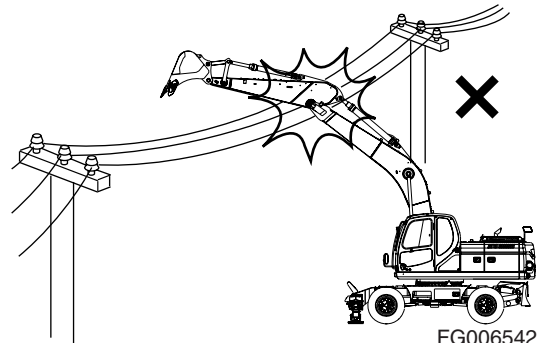

FG006542

Figure 24

Use these minimum distances as a guideline only. Depending upon the voltage in the line and atmospheric conditions, strong current shocks can occur with the boom or bucket as far away as 4 - 6 m (13 - 20 ft.) from the power line. Very high voltage and rainy weather could further decrease that safety margin.

**NOTE:** Before starting any type of operation near power lines (either above ground or buried cable type), you should always contact the power utility directly and work out a safety plan with them.

## Protecting Cabin from Falling Object (Optional)

In a work site where falling objects or flying objects are expected, be sure to install adequate protective devices for covering the cabin.

When using a breaker, be sure to install the front window protection guard (Figure 25).

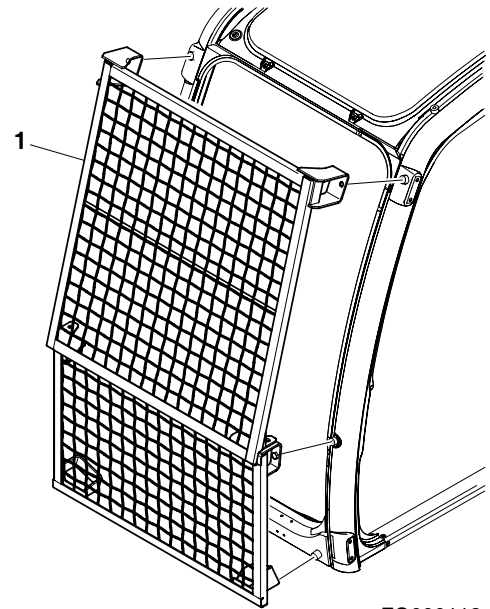

Figure 25

FG000112

In a work site where falling rocks can cause damage and possibly crush personnel, or in a mining operation, be sure to install the falling object protective structure (Figure 26).

Be sure to install any other additional protective structures required for work site conditions.

When the falling object protective structure is installed, and the front window needs to be cleaned, loosen the bolts marked with an arrow. Be sure to tighten bolts when done.

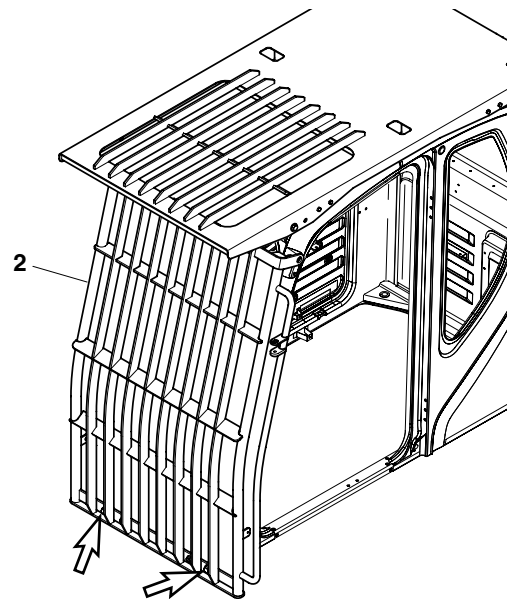

Figure 26

FG000113

## Operate Carefully on Snow, Ice and in Very Cold Temperatures

In icy cold weather avoid sudden travel movements and stay away from even slight slopes. The machine could skid off to one side very easily.

Snow accumulation could hide or obscure potential hazards. Use care while operating or while using the machine to clear snow.

Warming up the engine for a short period may be necessary, to avoid operating with sluggish or reduced working capacity. The jolting shocks and impact loads caused by bumping or bottoming the boom or attachment are more likely to cause severe stress in very cold temperatures. Reducing work cycle rate and work load may be necessary.

When the temperature rises, frozen road surfaces become soft, so the machine travel becomes unstable.

In cold weather, do not touch metal surfaces with your bare hands. If you touch a metal surface in extremely cold weather, your skin may freeze to the metal surface.

## Operations on Slopes

When working on slopes, there is danger that the machine may lose its balance and turn over, when swinging, or when work equipment is operated. Always carry out these operations carefully.

Do not swing the work equipment from the uphill side to the downhill side when the bucket is loaded. This operation is dangerous.

If the machine has to be used on a slope, pile the soil to make a platform that will keep the machine as horizontal as possible.

In addition, lower the bucket as far as possible, keep it pulled into the front, and keep the swing speed as low as possible.

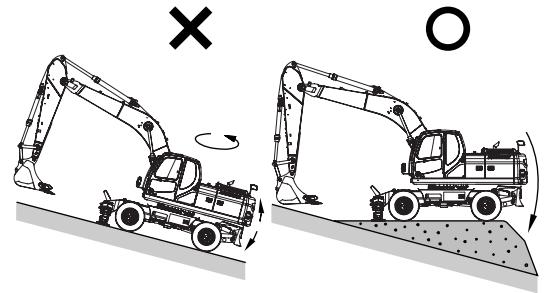

FG006543

Figure 27

## Parking Machine

Avoid making sudden stops, or parking the machine wherever it happens to be at the end of the work day. Plan ahead so that the excavator will be on firm, level ground away from traffic and away from high walls, cliff edges and any area of potential water accumulation or runoff. If parking on inclines is unavoidable, block the wheels to prevent movement. Lower the bucket or other working attachment completely to the ground, or to an overnight support saddle. There should be no possibility of unintended or accidental movement.

When parking on public roads, provide fences, signs, flags, or lights, and put up any other necessary signs to ensure that passing traffic can see the machine clearly, and park the machine so that the machine, flags, and fences do not obstruct traffic.

After the front attachment has been lowered to an overnight storage position and all switches and operating controls are in the "OFF" position, the safety lock lever must be set to the "LOCKED" position. This will disable all pilot circuit control functions.

Always close the door of the operator's compartment.

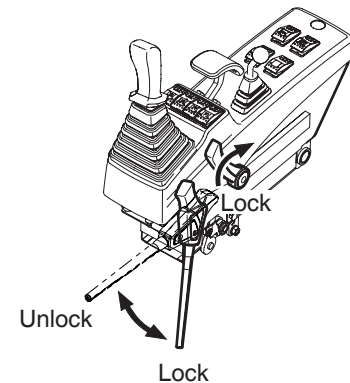
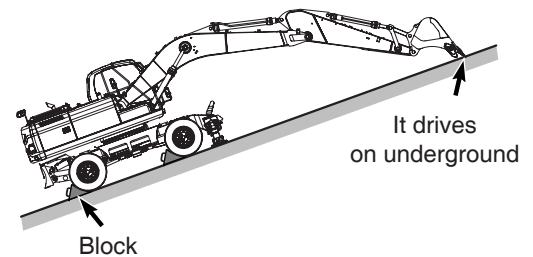

FG006544

Figure 28

## Never Let Anyone Ride on Attachment

Never let anyone ride on any work attachment, such as the bucket, crusher, grapple, or clamshell (grab bucket). There is a danger of the person falling and suffering serious injury.

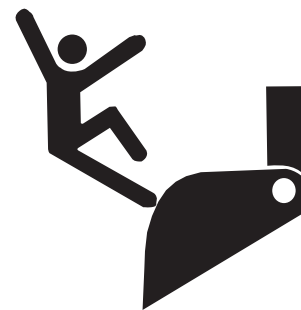

ARO1310L

Figure 29

# MAINTENANCE

## Warning Tag

Alert others that service or maintenance is being performed and tag operator's cabin controls – and other machine areas if required – with a warning notice. OSHA mandated control lever lockout can be made with any OSHA certified lockout device and a length of chain or cable to keep the safety lever in the fully lowered, nonactive position.

Warning tags, for controls are available from *DOOSAN* distributors.



ARO1320L

Figure 30

## Clean Before Inspection or Maintenance

Clean the machine before carrying out inspection and maintenance. This prevents dirt from getting into the machine and also ensures safety during maintenance.

If inspection and maintenance are carried out when the machine is dirty, it will become more difficult to locate the problems, and also there is danger that you may get dirt or mud in your eyes or that you may slip and injure yourself.

When washing the machine, do the following;

- Wear shoes with nonslip soles to prevent yourself from slipping and falling on wet places.
- Wear safety glasses and protective clothing when washing the machine with high-pressure steam.
- Take action to prevent touching high-pressure water and cutting your skin or having mud fly into your eyes.
- Do not spray water directly on electrical components (sensors, connector). If water gets into the electrical system, there is danger that it will cause defective operation and malfunction.

Pick up any tools or hammers that are laying in the work place, wipe up any grease or oil or any other slippery substances, and clean the area to make it possible to carry out the operation in safety. If the work place is left untidy, you may trip or slip and suffer injury.

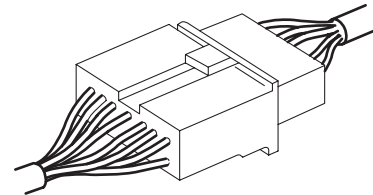
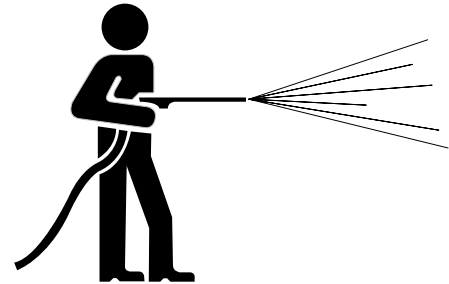

ARO1330L

Figure 31

## Proper Tools

Use only tools suited to the task. Using damaged, low quality, faulty, or makeshift tools could cause personal injury. There is danger that pieces from, chisels with crushed heads, or hammers, may get into your eyes and cause blindness.

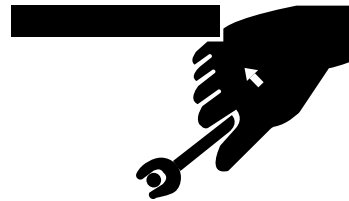

HDO1037L

Figure 32

## Use of Lighting

When checking fuel, oil, battery electrolyte, or window washing fluid, always use lighting with antiexplosion specifications. If such lighting equipment is not used, there is danger of an explosion.

If work is carried out in dark places without using lighting, it may lead to injury, so always use proper lighting.

Even if the place is dark, never use a lighter or flame instead of lighting. There is danger of fire. There is also danger that the battery gas may catch fire and cause an explosion.



HDO1040L

Figure 33

## Fire Prevention and Explosion Prevention

All fuels, most lubricants and some coolant mixtures are flammable. Leaking fuel or fuel that is spilled onto hot surfaces or onto electrical components can cause a fire.

Store all fuels and all lubricants in properly marked containers and away from all unauthorized persons.

Store oily rags and other flammable material in a protective container.

Do not smoke while you refuel the machine or while you are in a refueling area.

Do not smoke in battery charging areas or in areas that contain flammable material.

Clean all electrical connections and tighten all electrical connections. Check the electrical wires daily for wires that are loose or frayed. Tighten all loose electrical wires before you operate the machine. Repair all frayed electrical wires before you operate the machine.

Remove all flammable materials before they accumulate on the machine.

Do not weld on pipes or on tubes that contain flammable fluids. Do not flame cut on pipes or on tubes that contain flammable



HDO1015I

Figure 34

fluids. Before you weld on pipes or on tubes or before you flame cut on pipes or on tubes, clean the pipes or tubes thoroughly with a nonflammable solvent.

## Burn Prevention

When checking the radiator coolant level, shut down engine, let the engine and radiator cool down, then check the coolant recovery tank. If the coolant level in the coolant recovery tank is near the upper limit, there is enough coolant in the radiator.

Loosen the radiator cap gradually to release the internal pressure before removing the radiator cap.

If the coolant level in the coolant recovery tank is below the lower limit, add coolant.

Cooling system conditioner contains alkali. Alkali can cause personal injury. Do not allow alkali to contact the skin, the eyes, or the mouth.

Allow cooling system components to cool before you drain the cooling system.

Hot oil and hot components can cause personal injury. Do not allow hot oil or hot components to contact the skin.

Remove the hydraulic tank filter plug only after the engine has been stopped. Make sure that the hydraulic tank filter plug is cool before you remove it with your bare hand. Remove the hydraulic tank filter plug slowly to relieve pressure.

Relieve all pressure in the hydraulic oil system, in the fuel system, or in the cooling system before you disconnect any lines, fittings, or related items.

Batteries give off flammable fumes that can explode.

Do not smoke while you are checking the battery electrolyte levels.

Electrolyte is an acid. Electrolyte can cause personal injury. Do not allow electrolyte to contact the skin or the eyes.

Always wear protective glasses when you work on batteries.

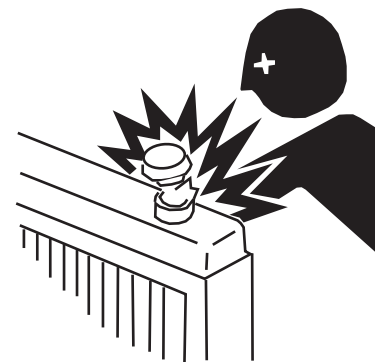
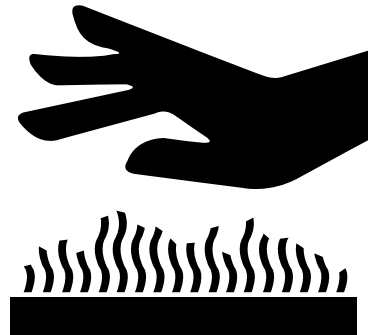

HAAE1980

Figure 35

## Welding Repairs



---

**When you connect or disconnect connectors between ECU and Engine or connector between ECU and the machine, always disconnect the source power to protect damage of the ECU.**

**If you don't observe this procedure, the ECU would be damaged or the engine would operate abnormally.**

---

When carrying out welding repairs, carry out the welding in a properly equipped place. The welding should be performed by a qualified worker. During welding operations, there is the danger of, generation of gas, fire, or electric shock, so never let an unqualified worker do welding.

The qualified welder must do the following;

- To prevent explosion of the battery, disconnect the battery terminals and remove batteries.
- To prevent generation of gas, remove the paint from the location of the weld.
- If hydraulic equipment, piping or places close to them are heated, a flammable gas or mist will be generated and there is danger of it catching fire. To avoid this, never subject these places to heat.
- Do not weld on pipes or on tubes that contain flammable fluids. Do not flame cut on pipes or on tubes that contain flammable fluids. Before you weld on pipes or on tubes or before you flame cut on pipes or on tubes, clean the pipes or tubes thoroughly with a nonflammable solvent.
- If heat is applied directly to rubber hoses or piping under pressure, they may suddenly break so cover them with a fireproof covering.
- Wear protective clothing.
- Make sure there is good ventilation.
- Remove all flammable objects and provide a fire extinguisher.

#### Treatment for Electrical Welding to the Body Structure

To prevent damage to ECU by electrical welding, please observe the following procedures:

1. Open the door of the battery cover.
2. Detach the cover after loosening the bolts on the battery.
3. Detach the positive and negative terminal cables from the battery.
4. Detach the undercover, and after that detach the connector (1) from the ECU that are installed at the engine.
5. Proceed with welding.

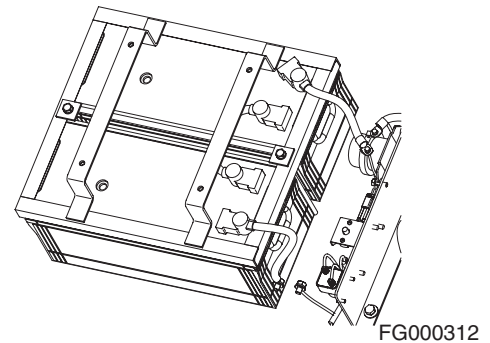

**Figure 36**

6. After welding, carefully reassemble the connector.
7. Connect the battery terminal cables.
8. Reassemble the undercover under the engine.
9. Reassemble the cover over the battery.
10. Close the cover of the battery.

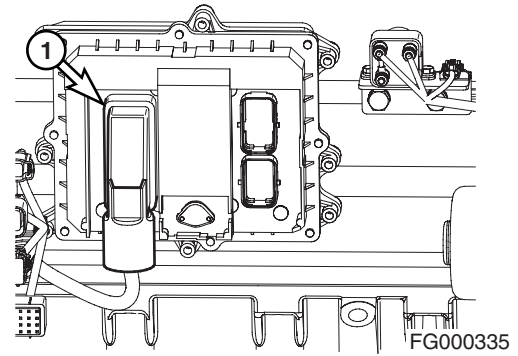

Figure 37

## Warning for Counterweight and Front Attachment Removal



*DOOSAN* warns any user, that the removal of the counterweight from the machine, front attachment or any other part, may affect the stability of the machine. This could cause unexpected movement, resulting in death or serious injuries. *DOOSAN* is not liable for any misuse.

Never remove the counterweight or front attachment unless the upper structure is in-line with the lower structure.

Never rotate the upper structure once the counterweight or front attachment has been removed.

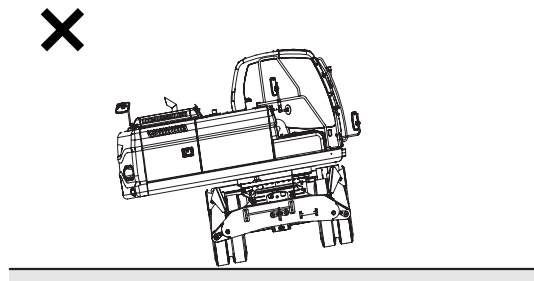
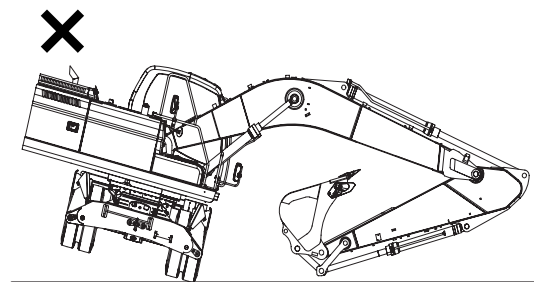

Figure 38

FG006545

## Precautions for Removal, Installation, and Storage of Attachments

Before starting removal and installation of attachments, decide the team leader.

Do not allow anyone except the authorized workers close to the machine or attachment.

Place attachments that have been removed from the machine in a safe place so that they do not fall. Put up a fence around the attachments and take other measures to prevent unauthorized persons from entering.



Figure 39

HDO1041L

## Precautions When Working on Machine

When carrying out maintenance operations on the machine, keep the area around your feet clean and tidy to prevent you from falling. Always do the following;

- Do not spill oil or grease.
- Do not leave tools laying about.
- Watch your step when walking.

Never jump down from the machine. When getting on or off the machine, use the steps and handrails, and maintain a three-point contact (both feet and one hand or both hands and one foot) to support yourself securely.

If the job requires it, wear protective clothing.

To prevent injury from slipping or falling, when working on the hood or covers, never use any part except the inspection passage fitted with nonslip pads.



ARO1380L

Figure 40

## Lock Inspection Covers

When carrying out maintenance with the inspection cover open, lock the cover securely in position with the lock bar.

If maintenance work is carried out with the inspection cover open but not locked, there is danger that it may suddenly close and cause injury if there is a gust of wind.

## Crushing Prevention and Cutting Prevention

You should always have at least two people working together if the engine must be run during service. One person needs to remain in the operator's seat, ready to work the controls or stop the machine and shut off the engine.

Unless you are instructed otherwise, never attempt adjustments while the machine is moving or while the engine is running.

Stay clear of all rotating parts and moving parts.

Keep objects away from moving fan blades. The fan blades will throw objects and the fan blades can cut objects.

Do not use a wire rope cable that is kinked or flayed. Wear gloves when you handle a wire rope cable.

When you strike a retainer pin, the retainer pin might fly out. The loose retainer pin can injure personnel. Make sure that the area is clear of people when you strike a retainer pin. To avoid injury to your eyes, wear protective glasses when you strike a retainer pin.

## Supports and Blocking for Work Equipment

Do not allow weight or equipment loads to remain suspended.

Lower everything to the ground before leaving the operator's seat.

Do not use hollow, cracked or unsteady wobbling supports.

Do not work under any equipment supported only by a lifting jack.

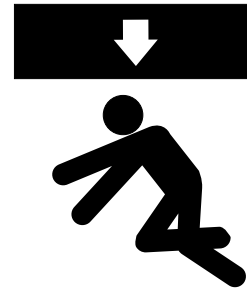

HDO1042L

Figure 41

## Action When Abnormality Is Found During Inspection

If any abnormality is found during inspection, always carry out repairs. In particular, if the machine is used when there are still problems with the brake or work equipment systems, it may lead to serious injury.

If necessary depending on the type of failure, please contact your *DOOSAN* distributor for repairs.

## Precautions with High-pressure Lines, Tubes and Hoses

When inspecting or replacing high-pressure piping or hoses, check that the pressure has been released from the circuit. Failure to release the pressure may lead to serious injury. Always do the following;

- Wear protective glasses and leather gloves.
- Fluid leaks from hydraulic hoses or pressurized components can be difficult to see but pressurized oil has enough force to pierce the skin and cause serious injury. Always use a piece of wood or cardboard to check for suspected hydraulic leaks. Never use your hands or expose your fingers.
- Do not bend high-pressure lines. Do not strike high-pressure lines. Do not install lines, tubes or hoses that are bent or damaged.
- Make sure that all clamps, guards and heat shields are installed correctly to prevent vibration, rubbing against other parts, and excessive heat during operation.
  - If any of the following conditions are found, replace the part.
  - Damage or leakage from hose end.
  - Wear, damage, cutting of covering, or exposure of strengthening wire layer.
  - Cover portion is swollen in places.

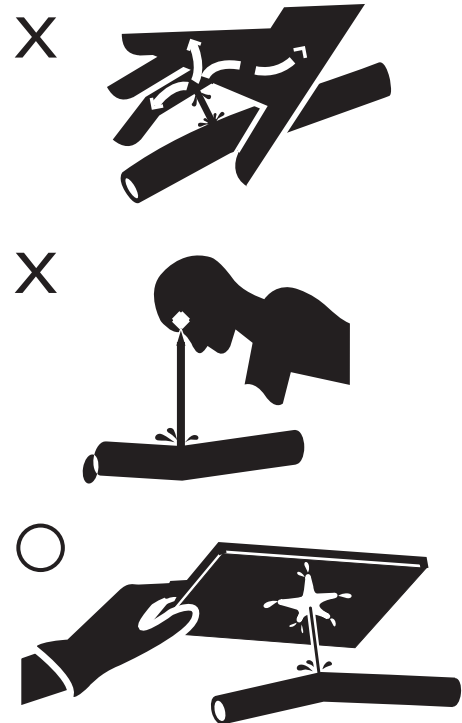

HDO1045I

Figure 42

- There is twisting or crushing at movable parts of hose.
- Foreign material is embedded in the covering.
- Hose end is deformed.

**NOTE:** Refer to “Hose In-service Lifetime Limit (European Standard ISO 8331 and EN982 CEN)” on page 4-62, for additional European regulations.

## Waste Materials

Physical contact with used motor oil may pose a health risk. Wipe oil from your hands promptly and wash off any remaining residue.

Used motor oil is an environmental contaminant and may only be disposed of at approved collection facilities. To prevent pollution of the environment, always do the following;

- Never dump waste oil in a sewer system, rivers, etc.
- Always put oil drained from your machine in containers. Never drain oil directly onto the ground.
- Obey appropriate laws and regulations when disposing of harmful materials such as oil, fuel, solvent, filters, and batteries.

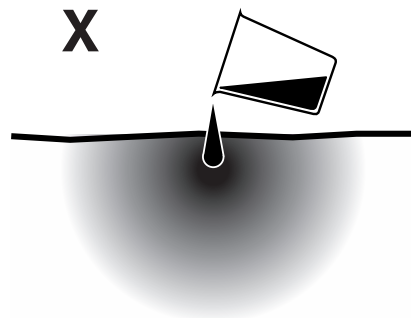

**Figure 43**

HAOA470L

# BATTERY

## Battery Hazard Prevention

Battery electrolyte contains diluted sulfuric acid and batteries generate hydrogen gas. Hydrogen gas is highly explosive, and mistakes in handling them can cause serious injury or fire. To prevent problems, always do the following;

- Do not smoke or bring any flame near the battery.
- When working with batteries, ALWAYS wear safety glasses and rubber gloves.
- If you spill battery electrolyte on yourself or your clothes, immediately flush the area with water.
- If battery electrolyte gets into your eyes, flush them immediately with large quantities of water and see a doctor at once.
- If you accidentally drink battery electrolyte, drink a large quantity of water or milk, raw egg or vegetable oil. Call a doctor or poison prevention center immediately.
- When cleaning the top surface of the battery, wipe it with a clean, damp cloth. Never use gasoline, thinner, or any other organic solvent or detergent.
- Tighten the battery caps securely.
- If the battery electrolyte is frozen, do not charge the battery or start the engine with power from another source. There is danger that the battery may catch fire.
- When charging the battery or starting with power from another source, let the battery electrolyte melt and check that there is no leakage of battery electrolyte before starting the operation.
- Always remove the battery from the machine before charging.

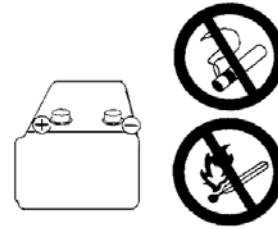

Figure 44

HAAE2100

## Boost Starting or Charging Engine Batteries

If any mistake is made in the method of connecting the booster cables, it may cause an explosion or fire. Always do the following;

- Turn off all electrical equipment before connecting leads to the battery. This includes electrical switches on the battery charger or boost starting equipment.
- When boost starting from another machine or vehicle do not allow the two machines to touch. Wear safety glasses or goggles while required battery connections are made.
- 24 volt battery units consisting of two series connected twelve volt batteries have a cable connecting one positive terminal on one of the 12 volt batteries to a negative terminal on the other battery. Booster or charger cable connections must be made between the nonseries connected positive terminals and between the negative terminal of the booster battery and the metal frame of the machine being boosted or charged. Refer to the procedure and illustration in "Starting Engine With a Booster Cable" on page 3-8 of this manual.
- Connect positive cable first when installing cables and disconnect the negative cable first when removing them. The final cable connection, at the metal frame of the machine being charged or boost started, should be as far away from the batteries as possible.

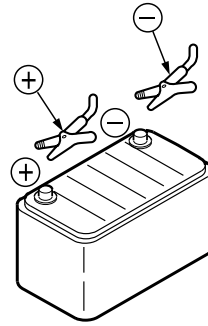

Figure 45

HAOA310L

# TOWING

## Precautions When Towing

If any mistake is made in the method of selecting or inspecting the towing wire or in the method of towing, it may lead to serious personal injury. Always do the following;

- Always use the method of towing given in this Operation and Maintenance Manual. Do not use any other method.
- Use leather gloves when handling the wire rope.
- When carrying out the preparation work for towing with two or more workers, determine the signals to use and follow these signals correctly.
- If the engine on the problem machine will not start or there is a failure in the brake system. always contact your *DOOSAN* distributor.
- Never go between the towing machine and the towed machine during the towing operation.
- It is dangerous to carry out towing on slopes, so select a place where the slope is gradual. If there is no place where the slope is gradual, carry out operations to reduce the angle of the slope before starting the towing operation.
- When towing a problem machine, always use a wire rope with a sufficient towing capacity.
- Do not use a frayed, kinked rope or a rope with any loss of diameter.
- Do not use the lightweight towing hook for towing another machine.
- Between machine and wire rope the thick piece of cloth put in and prevent the damage of equipment and wire rope.
- Towing speed must be below 10.0 km/h (6.21 MPH) and towing distance must not exceed 5.0 km/h (3.11 MPH). When towing distance is over 5.0 km/h (3.11 MPH) use a trailer.

# SHIPPING AND TRANSPORTATION

## Obey State and Local Over-the-Road Regulations

Check state and local restrictions regarding weight, width and length of a load before making any other preparation for transport.

The hauling vehicle, trailer and load must all be in compliance with local regulations governing the intended shipping route.

Partial disassembly or teardown of the excavator may be necessary to meet travel restrictions or particular conditions at the work site. See the Shop Manual for information on partial disassembly.

Refer to the Transportation and Shipping section of this Operation and Maintenance Manual for information on loading, unloading and towing.

# EXCAVATOR RATED LIFT CAPACITY TABLES

---

## WARNING!

Let everybody be away from the boom cylinder. While lifting operation, boom, arm, bucket hoses might burst and then high-pressure oil will be ejected at high speed.

If that failure mode takes place, handling weight or front structure might fall by its gravity to the ground to cause fatal injury to the person.

When changing the hoses record the part numbers of the hoses to factory log book.

Do the service job under the company's serviceman.

---

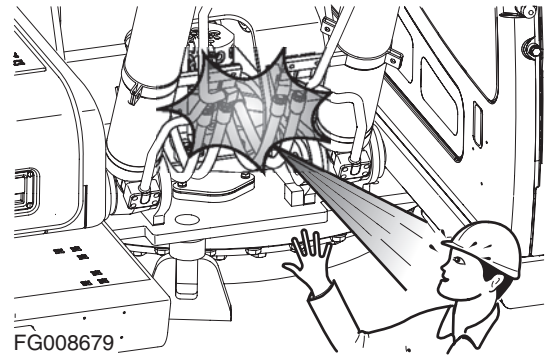

Figure 46

---

## WARNING!

All rated lift capacities are based on the machine and the load both remaining level at all times. **DO NOT EXCEED THE RATED LIFT CAPACITY.** Lifting loads greater than those shown in the rated capacity tables can cause catastrophic equipment failure and/or structural collapse of the machine.

---

To operate safely the excavator should be on a firm, level and uniformly supporting surface. The operator is expected to make due allowance for all specific work site and lift related conditions, and respond to changes in those conditions that could pose a hazard. The following could all cause hazardous conditions and accidents or injuries:

- Soft or uneven ground.
- Unlevel terrain.
- Side loads.
- Modifications or poor maintenance of the excavator.
- Failure to lift squarely over the end or over the side of the machine.

When a load is in the air, the operator must remain alert.

- Avoid side loads that may be caused by uneven slings, traveling with the load or swinging too quickly.
- The load can become unbalanced if the hook line is twisted and starts to rotate. If the surface area of the load is large enough, wind gusts can create side loads.
- Keep the bucket hook point directly over the load. Tag lines on opposite sides of the load can help

maintain greater stability against side loads and wind gusts.

Avoid traveling with a suspended load. Before swinging (or if required, traveling), bring the load into an arm position (radius and height) that has a safer weight capacity rating and adequate movement clearance. The operator and all work site personnel should be thoroughly familiar with safety instructions and procedures within this Operation and Maintenance Manual.

The following weight loads are in compliance with SAE (J1097) and ISO applicable, recommended standards for hydraulic excavators performing lifting operation on a firm supporting surface. An asterisk (\*) next to the lift rating indicates rated load does not exceed 87% of hydraulic capacity. All other ratings have been determined not to exceed 75% of tipping capacity.

Do not attempt to lift or hold any load that exceeds rated load capacity at the specified distances (from the machine's rotation center line and height - see "lift radius" and "lift height" in the reference drawing, Figure 47).

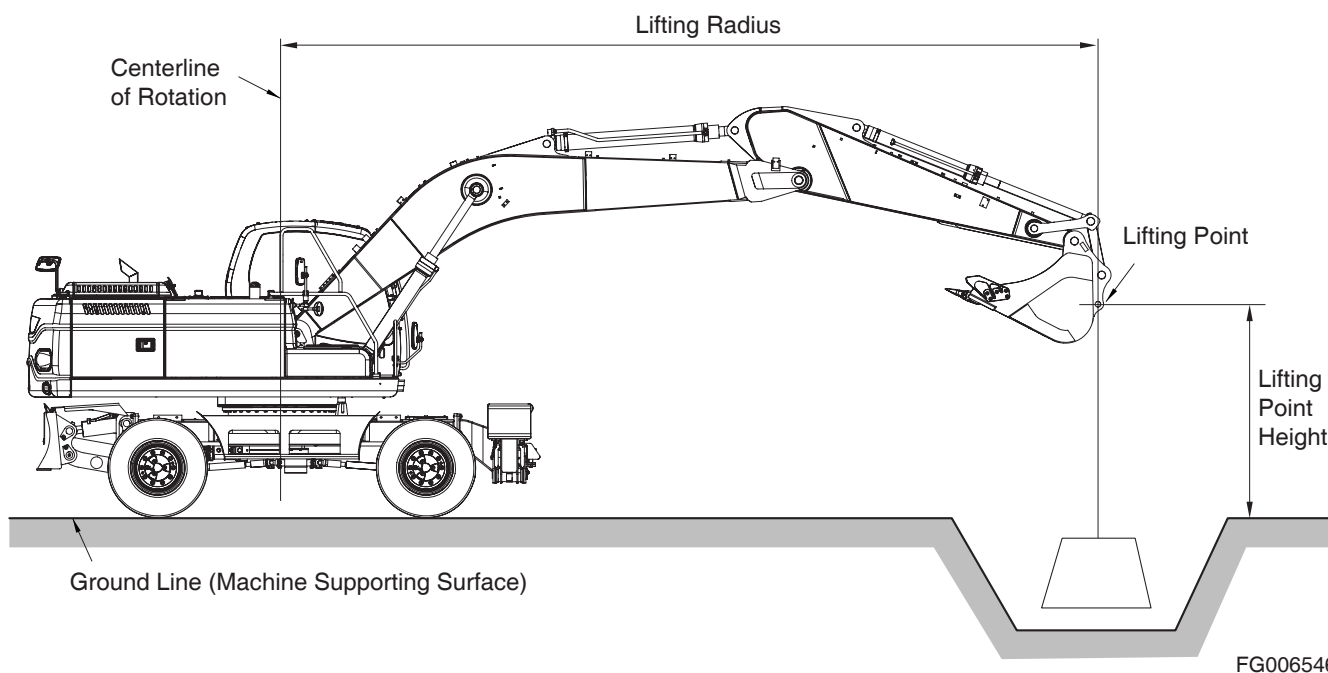

**Figure 47**

The weight of slings and any auxiliary lifting device (and/or the weight difference of any attachment heavier than standard configuration) must be deducted from the rated lift capacity to determine allowable net lifting load. The lift point should be on the back of the bucket, as shown in Figure 47.

---

## **IMPORTANT**

---

Select the Digging Mode switch on the Instrument Panel before using the excavator for lifting work. Engine and hydraulic oil should both be fully warmed up to operating temperature before starting a lift.

---

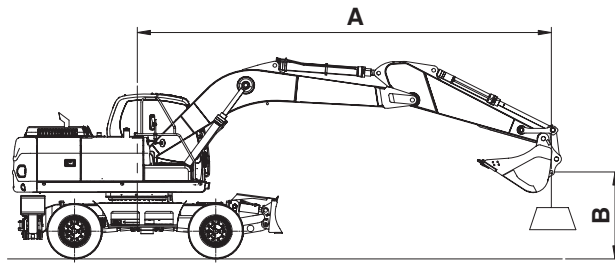















Boom : 5.2 m (17' 1") One-Piece Boom  
 Arm : 2.6 m (8' 6")  
 Bucket : Without Bucket  
 UNIT : 1000 kg (1000 lb)  
 : Rated lift capacity - over front  
 (Free on wheel /  
 Dozer and outrigger on ground)  
 : Rated lift capacity - over side  
 (Free on wheel /  
 Dozer and outrigger on ground)

FG008826











Figure 48

**METRIC (5.2 m One-Piece Boom, 2.6 m Arm)**

A (m) B (m)	Chassis Frame Attachment	2		3		4		5		6		7		Max. Reach		
																A
8	R-Rear Dozer Only Up													*3.84	*3.84	4.72
	R-Rear Dozer Only Down													*3.84	*3.84	4.72
	R-Outrigger Only Down													*3.84	*3.84	4.72
	F-Dozer + R-Outrigger Down													*3.84	*3.84	4.72
7	R-Rear Dozer Only Up													*3.51	3.29	5.83
	R-Rear Dozer Only Down													*3.51	*3.51	5.83
	R-Outrigger Only Down													*3.51	*3.51	5.83
	F-Dozer + R-Outrigger Down													*3.51	*3.51	5.83
6	R-Rear Dozer Only Up									*5.09	3.17			*3.37	2.72	6.59
	R-Rear Dozer Only Down									*5.09	4.09			*3.37	*3.37	6.59
	R-Outrigger Only Down									5.00	*5.09			*3.37	*3.37	6.59
	F-Dozer + R-Outrigger Down									*5.09	*5.09			*3.37	*3.37	6.59
5	R-Rear Dozer Only Up							*5.84	4.12	5.23	3.14	*4.03	2.47	*3.33	2.39	7.13
	R-Rear Dozer Only Down							*5.84	5.36	5.12	4.06	*4.03	3.20	*3.33	3.10	7.13
	R-Outrigger Only Down							*5.84	*5.84	4.97	*5.57	3.90	*4.03	*3.33	*3.33	7.13
	F-Dozer + R-Outrigger Down							*5.84	*5.84	*5.57	*5.57	*4.03	*4.03	*3.33	*3.33	7.13
4	R-Rear Dozer Only Up			*9.56	8.52	*7.57	5.53	*6.54	4.01	5.17	3.08	4.10	2.45	*3.36	2.20	7.50
	R-Rear Dozer Only Down			*9.56	*9.56	*7.57	7.37	*6.54	5.24	5.06	4.00	4.01	3.18	*3.36	2.86	7.50
	R-Outrigger Only Down			*9.56	*9.56	*7.57	*7.57	6.49	*6.54	4.90	5.79	3.88	4.56	*3.36	*3.36	7.50
	F-Dozer + R-Outrigger Down			*9.56	*9.56	*7.57	*7.57	*6.54	*6.54	*5.94	5.79	*5.45	4.56	*3.36	*3.36	7.50
3	R-Rear Dozer Only Up					*9.11	5.28	6.68	3.88	5.09	3.00	4.06	2.41	*3.44	2.08	7.71
	R-Rear Dozer Only Down					*9.11	7.09	6.54	5.10	4.97	3.92	3.96	3.14	3.43	2.72	7.71
	R-Outrigger Only Down					9.03	*9.11	6.34	*7.39	4.82	5.70	3.83	4.51	3.32	*3.44	7.71
	F-Dozer + R-Outrigger Down					*9.11	*9.11	*7.39	*7.39	*6.42	5.70	*5.83	4.51	*3.44	*3.44	7.71
2	R-Rear Dozer Only Up					9.24	5.06	6.54	3.75	5.00	2.93	4.01	2.37	3.44	2.03	7.79
	R-Rear Dozer Only Down					9.04	6.85	6.39	4.96	4.89	3.84	3.92	3.09	3.35	2.65	7.79
	R-Outrigger Only Down					8.75	*10.50	6.19	7.43	4.73	5.61	3.79	4.46	3.24	*3.59	7.79
	F-Dozer + R-Outrigger Down					*10.50	*10.50	*8.20	7.43	*6.90	5.61	*6.09	4.46	*3.59	*3.59	7.79
1	R-Rear Dozer Only Up					9.06	4.91	6.42	3.65	4.93	2.86	3.97	2.33	3.45	2.03	7.74
	R-Rear Dozer Only Down					8.86	6.68	6.28	4.86	4.82	3.77	3.87	3.05	3.37	2.66	7.74
	R-Outrigger Only Down					8.57	10.56	6.07	7.30	4.66	5.54	3.74	4.42	3.25	*3.80	7.74
	F-Dozer + R-Outrigger Down					*11.35	10.56	*8.81	7.30	*7.29	5.54	*6.30	4.42	*3.80	*3.80	7.74



A (m) B (m)	Chassis Frame Attachment	2		3		4		5		6		7		Max. Reach		A
																
0	R-Rear Dozer Only Up			*5.74	*5.74	8.97	4.84	6.35	3.58	4.88	2.82	3.94	2.30	3.55	2.08	7.55
	R-Rear Dozer Only Down			*5.74	*5.74	8.77	6.60	6.20	4.79	4.77	3.72	3.85	3.02	3.47	2.73	7.55
	R-Outrigger Only Down			*5.74	*5.74	8.48	10.47	6.00	7.23	4.61	5.48	3.72	4.39	3.35	3.95	7.55
	F-Dozer + R-Outrigger Down			*5.74	*5.74	*11.61	10.47	*9.11	7.23	*7.50	5.48	*6.36	4.39	*4.12	3.95	7.55
-1	R-Rear Dozer Only Up	*5.29	*5.29	*8.62	7.35	8.94	4.82	6.32	3.56	4.86	2.80	3.93	2.30	3.78	2.21	7.22
	R-Rear Dozer Only Down	*5.29	*5.29	*8.62	*8.62	8.74	6.58	6.17	4.76	4.74	3.70	3.84	3.02	3.69	2.9	7.22
	R-Outrigger Only Down	*5.29	*5.29	*8.62	*8.62	8.46	10.44	5.97	7.19	4.59	5.46	3.71	4.38	3.56	4.21	7.22
	F-Dozer + R-Outrigger Down	*5.29	*5.29	*8.62	*8.62	*11.40	10.44	*9.07	7.19	*7.45	5.46	*6.17	4.38	*4.60	4.21	7.22
2	R-Rear Dozer Only Up	*8.48	*8.48	*12.39	7.40	8.97	4.83	6.32	3.56	4.87	2.81			4.18	2.44	6.72
	R-Rear Dozer Only Down	*8.48	*8.48	*12.39	10.59	8.77	6.60	6.18	4.76	4.75	3.71			4.08	3.21	6.72
	R-Outrigger Only Down	*8.48	*8.48	*12.39	*12.39	8.48	10.46	5.98	7.2	4.6	5.47			3.95	4.67	6.72
	F-Dozer + R-Outrigger Down	*8.48	*8.48	*12.39	*12.39	*10.74	10.46	*8.63	7.2	*7.03	5.47			*5.36	4.67	6.72
-3	R-Rear Dozer Only Up	*12.31	*12.31	*11.96	7.50	9.04	4.89	6.37	3.61	4.93	2.86			4.93	2.86	6.00
	R-Rear Dozer Only Down	*12.31	*12.31	*11.96	10.69	8.83	6.66	6.23	4.81	4.81	3.77			4.81	3.77	6.00
	R-Outrigger Only Down	*12.31	*12.31	*11.96	*11.96	8.55	*9.54	6.03	7.25	4.66	5.53			4.66	5.53	6.00
	F-Dozer + R-Outrigger Down	*12.31	*12.31	*11.96	*11.96	*9.54	*9.54	*7.66	7.25	*5.85	5.53			*5.85	5.53	6.00
-4	R-Rear Dozer Only Up			*9.33	7.65	*7.46	5.00							*5.50	3.73	4.98
	R-Rear Dozer Only Down			*9.33	*9.33	*7.46	6.78							*5.50	4.96	4.98
	R-Outrigger Only Down			*9.33	*9.33	*7.46	*7.46							*5.50	*5.50	4.98
	F-Dozer + R-Outrigger Down			*9.33	*9.33	*7.46	*7.46							*5.50	*5.50	4.98

## FEET (17' 1" One-Piece Boom, 8' 6" Arm)

A (ft) B (ft)	Chassis Frame Attachment	10		15		20		25		Max. Reach		
												A
25	R-Rear Dozer Only Up									*8.12	*8.12	17.04
	R-Rear Dozer Only Down									*8.12	*8.12	17.04
	R-Outrigger Only Down									*8.12	*8.12	17.04
	F-Dozer + R-Outrigger									*8.12	*8.12	17.04
20	R-Rear Dozer Only Up					*10.62	6.81			*7.45	6.08	21.42
	R-Rear Dozer Only Down					*10.62	8.80			*7.45	*7.45	21.42
	R-Outrigger Only Down					*10.62	*10.62			*7.45	*7.45	21.42
	F-Dozer + R-Outrigger					*10.62	*10.62			*7.45	*7.45	21.42
15	R-Rear Dozer Only Up			*14.02	10.23	11.21	6.71			*7.35	5.06	23.97
	R-Rear Dozer Only Down			*14.02	13.42	10.97	8.69			*7.35	6.58	23.97
	R-Outrigger Only Down			*14.02	*14.02	10.63	*12.51			*7.35	*7.35	23.97
	F-Dozer + R-Outrigger			*14.02	*14.02	*12.51	*12.51			*7.35	*7.35	23.97
10	R-Rear Dozer Only Up	*27.19	17.16	16.94	9.69	10.96	6.48	7.89	4.68	*7.57	4.60	25.28
	R-Rear Dozer Only Down	*27.19	24.12	16.58	12.83	10.72	8.46	7.70	6.10	*7.57	6.00	25.28
	R-Outrigger Only Down	*27.19	*27.19	16.07	*17.51	10.38	12.27	7.45	8.75	7.32	*7.57	25.28
	F-Dozer + R-Outrigger	*27.19	*27.19	*17.51	*17.51	*13.95	12.27	*8.89	8.75	*7.57	*7.57	25.28
5	R-Rear Dozer Only Up			16.34	9.18	10.7	6.25	7.79	4.59	7.56	4.46	25.53
	R-Rear Dozer Only Down			15.98	12.28	10.46	8.21	7.61	6.01	7.38	5.83	25.53
	R-Outrigger Only Down			15.47	18.74	10.12	12.00	7.36	8.66	7.14	*8.11	25.53
	F-Dozer + R-Outrigger			*20.72	18.74	*15.44	12.00	*10.90	8.66	*8.11	*8.11	25.53
0 (GND)	R-Rear Dozer Only Up	*13.23	*13.23	16.01	8.90	10.52	6.09			7.83	4.60	24.77
	R-Rear Dozer Only Down	*13.23	*13.23	15.65	11.98	10.28	8.04			7.65	6.03	24.77
	R-Outrigger Only Down	*13.23	*13.23	15.14	18.38	9.94	11.81			7.39	8.71	24.77
	F-Dozer + R-Outrigger	*13.23	*13.23	*22.14	18.38	*16.25	11.81			*9.09	8.71	24.77
-5	R-Rear Dozer Only Up	*23.63	15.86	15.94	8.84	10.47	6.05			8.73	5.1	22.89
	R-Rear Dozer Only Down	*23.63	22.62	15.58	11.91	10.23	7.99			8.52	6.71	22.89
	R-Outrigger Only Down	*23.63	*23.63	15.07	18.31	9.89	11.76			8.24	9.74	22.89
	F-Dozer + R-Outrigger	*23.63	*23.63	*21.49	18.31	*15.76	11.76			*10.91	9.74	22.89
-10	R-Rear Dozer Only Up	*25.85	16.13	16.09	8.97					10.97	6.37	19.55
	R-Rear Dozer Only Down	*25.85	22.94	15.73	12.05					10.72	8.39	19.55
	R-Outrigger Only Down	*25.85	*25.85	15.22	*18.42					10.37	12.32	19.55
	F-Dozer + R-Outrigger	*25.85	*25.85	*18.42	*18.42					*12.88	12.32	19.55

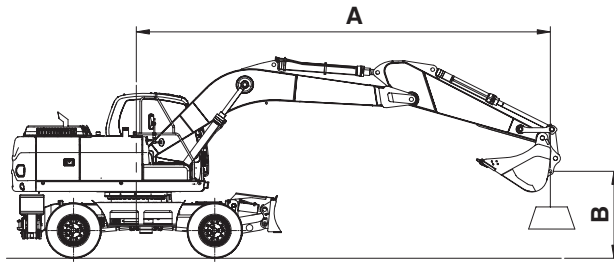
1. Ratings are based on SAE J1097.
2. Load point is the hook on the back of the bucket.
3. \* Rated loads are based on hydraulic capacity.
4. Rated loads do not exceed 87% of hyd. Capacity or 75% of tipping capacity.































Boom : 5.2 m (17' 1") One-Piece Boom  
 Arm : 2.2 m (7' 3")  
 Bucket : Without Bucket  
 UNIT : 1000 kg (1000 lb)  
 : Rated lift capacity - over front  
 (Free on wheel /  
 Dozer and outrigger on ground)  
 : Rated lift capacity - over side  
 (Free on wheel /  
 Dozer and outrigger on ground)

FG008693









Figure 49

**METRIC (5.2 m One-Piece Boom, 2.2 m Arm)**

A (m) B (m)	Chassis Frame Attachment	2		3		4		5		6		7		Max. Reach		A
																
8	R-Rear Dozer Only Up															
	R-Rear Dozer Only Down															
	R-Outrigger Only Down															
	F-Dozer + R-Outrigger Down															
7	R-Rear Dozer Only Up							*6.00	4.14					*5.02	3.76	5.31
	R-Rear Dozer Only Down							*6.00	5.39					*5.02	4.88	5.31
	R-Outrigger Only Down							*6.00	*6.00					*5.02	*5.02	5.31
	F-Dozer + R-Outrigger Down							*6.00	*6.00					*5.02	*5.02	5.31
6	R-Rear Dozer Only Up							*5.91	4.15	5.22	3.13			*4.77	3.01	6.14
	R-Rear Dozer Only Down							*5.91	5.39	5.11	4.05			*4.77	3.90	6.14
	R-Outrigger Only Down							*5.91	*5.91	4.95	*5.54			4.77	*4.77	6.14
	F-Dozer + R-Outrigger Down							*5.91	*5.91	*5.54	*5.54			*4.77	*4.77	6.14
5	R-Rear Dozer Only Up							*6.30	4.08	5.21	3.11			4.37	2.61	6.72
	R-Rear Dozer Only Down							*6.30	5.32	5.09	4.04			4.27	3.39	6.72
	R-Outrigger Only Down							*6.30	*6.30	4.94	5.83			4.13	*4.69	6.72
	F-Dozer + R-Outrigger Down							*6.30	*6.30	*5.94	5.83			*4.69	*4.69	6.72
4	R-Rear Dozer Only Up					*8.23	5.45	6.79	3.97	5.15	3.06	4.08	2.43	3.99	2.38	7.10
	R-Rear Dozer Only Down					*8.23	7.28	6.64	5.20	5.03	3.98	3.99	3.16	3.90	3.09	7.10
	R-Outrigger Only Down					*8.23	*8.23	6.44	*6.97	4.88	5.76	3.86	4.54	3.77	4.43	7.10
	F-Dozer + R-Outrigger Down					*8.23	*8.23	*6.97	*6.97	*6.26	5.76	*5.53	4.54	*4.72	4.43	7.10
3	R-Rear Dozer Only Up					9.41	5.20	6.64	3.84	5.07	2.99	4.05	2.40	3.78	2.24	7.33
	R-Rear Dozer Only Down					9.20	7.00	6.50	5.06	4.96	3.90	3.96	3.13	3.69	2.92	7.33
	R-Outrigger Only Down					8.92	*9.73	6.29	7.54	4.80	5.68	3.83	4.50	3.57	4.20	7.33
	F-Dozer + R-Outrigger Down					*9.73	*9.73	*7.77	7.54	*6.69	5.68	*6.06	4.50	*4.84	4.20	7.33
2	R-Rear Dozer Only Up					9.16	4.99	6.50	3.72	4.99	2.92	4.01	2.37	3.69	2.18	7.42
	R-Rear Dozer Only Down					8.95	6.77	6.36	4.93	4.88	3.83	3.91	3.09	3.61	2.85	7.42
	R-Outrigger Only Down					8.67	10.67	6.16	7.39	4.72	5.60	3.79	4.46	3.49	4.10	7.42
	F-Dozer + R-Outrigger Down					*10.96	10.67	*8.50	7.39	*7.12	5.60	*6.26	4.46	*5.05	4.10	7.42
1	R-Rear Dozer Only Up					9.01	4.87	6.40	3.63	4.93	2.86	3.97	2.34	3.71	2.18	7.36
	R-Rear Dozer Only Down					8.81	6.64	6.26	4.84	4.81	3.77	3.88	3.06	3.62	2.86	7.36
	R-Outrigger Only Down					8.53	10.51	6.05	7.28	4.66	5.53	3.75	4.43	3.50	4.12	7.36
	F-Dozer + R-Outrigger Down					*11.56	10.51	*8.99	7.28	*7.43	5.53	*6.38	4.43	*5.38	4.12	7.36
0	R-Rear Dozer Only Up					8.96	4.83	6.34	3.58	4.89	2.83	3.96	2.32	3.84	2.25	7.16
	R-Rear Dozer Only Down					8.76	6.59	6.20	4.79	4.77	3.73	3.86	3.04	3.75	2.95	7.16
	R-Outrigger Only Down					8.47	10.45	6.00	7.22	4.62	5.49	3.73	4.41	3.62	4.27	7.16
	F-Dozer + R-Outrigger Down					*11.58	10.45	*9.15	7.22	*7.53	5.49	*6.33	4.41	*5.87	4.27	7.16



A (m) B (m)	Chassis Frame Attachment	2		3		4		5		6		7		Max. Reach		A
																
-1	R-Rear Dozer Only Up			*8.80	7.39	8.96	4.83	6.33	3.57	4.88	2.82			4.11	2.41	6.81
	R-Rear Dozer Only Down			*8.80	*8.80	8.76	6.59	6.18	4.77	4.76	3.72			4.02	3.16	6.81
	R-Outrigger Only Down			*8.80	*8.80	8.47	10.45	5.98	7.21	4.61	5.48			3.88	4.59	6.81
	F-Dozer + R-Outrigger Down			*8.80	*8.80	*11.15	10.45	*8.96	7.21	*7.35	5.48			*6.19	4.59	6.81
2	R-Rear Dozer Only Up	*9.45	*9.45	*12.76	7.46	9.00	4.87	6.35	3.59	4.90	2.84			4.62	2.70	6.27
	R-Rear Dozer Only Down	*9.45	*9.45	*12.76	10.65	8.80	6.63	6.21	4.79	4.79	3.75			4.52	3.55	6.27
	R-Outrigger Only Down	*9.45	*9.45	*12.76	*12.76	8.52	*10.30	6.01	7.23	4.63	5.51			4.37	5.18	6.27
	F-Dozer + R-Outrigger Down	*9.45	*9.45	*12.76	*12.76	*10.30	*10.30	*8.34	7.23	*6.69	5.51			*6.18	5.18	6.27
-3	R-Rear Dozer Only Up	*13.23	*13.23	*10.85	7.56	*8.84	4.94	6.43	3.66					5.62	3.25	5.50
	R-Rear Dozer Only Down	*13.23	*13.23	*10.85	10.77	*8.84	6.72	6.28	4.86					5.49	4.29	5.50
	R-Outrigger Only Down	*13.23	*13.23	*10.85	*10.85	8.61	*8.84	6.08	*7.04					5.32	*6.00	5.50
	F-Dozer + R-Outrigger Down	*13.23	*13.23	*10.85	*10.85	*8.84	*8.84	*7.04	*7.04					*6.00	*6.00	5.50
-4	R-Rear Dozer Only Up			*7.78	7.75	*6.14	5.09							*5.33	4.54	4.36
	R-Rear Dozer Only Down			*7.78	*7.78	*6.14	*6.14							*5.33	*5.33	4.36
	R-Outrigger Only Down			*7.78	*7.78	*6.14	*6.14							*5.33	*5.33	4.36
	F-Dozer + R-Outrigger Down			*7.78	*7.78	*6.14	*6.14							*5.33	*5.33	4.36

## FEET (17' 1" One-Piece Boom, 7' 3" Arm)

A (ft) B (ft)	Chassis Frame Attachment	10		15		20		Max. Reach		A
										
25	R-Rear Dozer Only Up							*11.75	10.27	15.10
	R-Rear Dozer Only Down							*11.75	*11.75	15.10
	R-Outrigger Only Down							*11.75	*11.75	15.10
	F-Dozer + R-Outrigger							*11.75	*11.75	15.10
20	R-Rear Dozer Only Up							*10.56	6.76	19.92
	R-Rear Dozer Only Down							*10.56	8.75	19.92
	R-Outrigger Only Down							*10.56	*10.56	19.92
	F-Dozer + R-Outrigger							*10.56	*10.56	19.92
15	R-Rear Dozer Only Up			*15.16	10.13	11.16	6.66	9.21	5.50	22.65
	R-Rear Dozer Only Down			*15.16	13.3	10.91	8.64	9.00	7.14	22.65
	R-Outrigger Only Down			*15.16	*15.16	10.57	12.48	8.72	10.25	22.65
	F-Dozer + R-Outrigger			*15.16	*15.16	*13.28	12.48	*10.35	10.25	22.65
10	R-Rear Dozer Only Up			16.80	9.58	10.92	6.45	8.35	4.96	24.03
	R-Rear Dozer Only Down			16.44	12.71	10.68	8.42	8.16	6.46	24.03
	R-Outrigger Only Down			15.93	*18.52	10.34	12.23	7.89	9.28	24.03
	F-Dozer + R-Outrigger			*18.52	*18.52	*14.54	12.23	*10.65	9.28	24.03
5	R-Rear Dozer Only Up			16.25	9.11	10.68	6.24	8.13	4.80	24.30
	R-Rear Dozer Only Down			15.89	12.2	10.44	8.19	7.94	6.27	24.30
	R-Outrigger Only Down			15.38	18.64	10.10	11.98	7.67	9.03	24.30
	F-Dozer + R-Outrigger			*21.34	18.64	*15.82	11.98	*11.45	9.03	24.30
0 (GND)	R-Rear Dozer Only Up			15.99	8.89	10.54	6.11	8.46	4.97	23.50
	R-Rear Dozer Only Down			15.63	11.96	10.29	8.05	8.26	6.51	23.50
	R-Outrigger Only Down			15.12	18.36	9.95	11.83	7.99	9.42	23.50
	F-Dozer + R-Outrigger			*22.20	18.36	*16.33	11.83	*12.95	9.42	23.50
-5	R-Rear Dozer Only Up	*25.67	15.96	15.99	8.89	10.54	6.11	9.57	5.60	21.50
	R-Rear Dozer Only Down	*25.67	22.73	15.63	11.96	10.30	8.06	9.35	7.35	21.50
	R-Outrigger Only Down	*25.67	*25.67	15.12	18.36	9.96	11.83	9.04	10.7	21.50
	F-Dozer + R-Outrigger	*25.67	*25.67	*20.97	18.36	*15.30	11.83	*13.65	10.7	21.50
-10	R-Rear Dozer Only Up	*23.44	16.28	16.21	9.08			12.55	7.25	17.90
	R-Rear Dozer Only Down	*23.44	23.10	15.85	12.17			12.26	9.57	17.90
	R-Outrigger Only Down	*23.44	*23.44	15.34	*17.01			11.87	*13.20	17.90
	F-Dozer + R-Outrigger	*23.44	*23.44	*17.01	*17.01			*13.20	*13.20	17.90

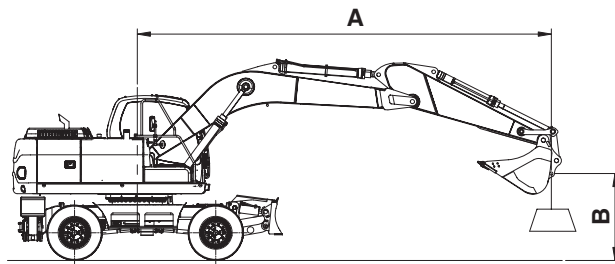
1. Ratings are based on SAE J1097.
2. Load point is the hook on the back of the bucket.
3. \* Rated loads are based on hydraulic capacity.
4. Rated loads do not exceed 87% of hyd. Capacity or 75% of tipping capacity.



































Boom : 5.2 m (17' 1") One-Piece Boom  
 Arm : 3.1 m (10' 2")  
 Bucket : Without Bucket  
 UNIT : 1000 kg (1000 lb)  
 : Rated lift capacity - over front  
 (Free on wheel / Dozer and outrigger on ground)  
 : Rated lift capacity - over side  
 (Free on wheel / Dozer and outrigger on ground)

FG008694











Figure 50

**METRIC (5.2 m One-Piece Boom, 3.1 m Arm)**

A (m)	B (m)	Chassis Frame Attachment	2		3		4		5		6		7		8		Max. Reach			
																			A	
8		R-Rear Dozer Only Up																*3.44	*3.44	5.30
		R-Rear Dozer Only Down																*3.44	*3.44	5.30
		R-Outrigger Only Down																*3.44	*3.44	5.30
		F-Dozer + R-Outrigger Down																*3.44	*3.44	5.30
7		R-Rear Dozer Only Up									*3.91	3.17						*3.24	2.93	6.30
		R-Rear Dozer Only Down									*3.91	*3.91						*3.24	*3.24	6.30
		R-Outrigger Only Down									*3.91	*3.91						*3.24	*3.24	6.30
		F-Dozer + R-Outrigger Down									*3.91	*3.91						*3.24	*3.24	6.30
6		R-Rear Dozer Only Up									*4.70	3.18	*3.19	2.47				*3.16	2.46	7.01
		R-Rear Dozer Only Down									*4.70	4.11	*3.19	*3.19				*3.16	*3.16	7.01
		R-Outrigger Only Down									*4.70	*4.70	*3.19	*3.19				*3.16	*3.16	7.01
		F-Dozer + R-Outrigger Down									*4.70	*4.70	*3.19	*3.19				*3.16	*3.16	7.01
5		R-Rear Dozer Only Up									*5.05	3.14	4.12	2.46				*3.15	2.18	7.52
		R-Rear Dozer Only Down									*5.05	4.06	4.03	3.20				*3.15	2.85	7.52
		R-Outrigger Only Down									4.97	*5.05	3.9	*4.44				*3.15	*3.15	7.52
		F-Dozer + R-Outrigger Down									*5.05	*5.05	*4.44	*4.44				*3.15	*3.15	7.52
4		R-Rear Dozer Only Up							*5.92	4.02	5.17	3.07	4.08	2.42				*3.20	2.01	7.87
		R-Rear Dozer Only Down							*5.92	5.26	5.05	3.99	3.99	3.16				*3.20	2.63	7.87
		R-Outrigger Only Down							*5.92	*5.92	4.90	*5.46	3.86	4.54				*3.20	*3.20	7.87
		F-Dozer + R-Outrigger Down							*5.92	*5.92	*5.46	*5.46	*5.18	4.54				*3.20	*3.20	7.87
3		R-Rear Dozer Only Up		*11.07	8.11	*8.20	5.32	6.69	3.87	5.07	2.98	4.03	2.37	3.29	1.93			3.25	1.90	8.07
		R-Rear Dozer Only Down		*11.07	*11.07	*8.20	7.14	6.54	5.10	4.95	3.90	3.93	3.10	3.22	2.54			3.17	2.50	8.07
		R-Outrigger Only Down		*11.07	*11.07	*8.20	*8.20	6.34	*6.80	4.80	5.69	3.81	4.49	3.11	*3.64	3.06		*3.31	*3.31	8.07
		F-Dozer + R-Outrigger Down		*11.07	*11.07	*8.20	*8.20	*6.80	*6.80	*5.99	5.69	*5.47	4.49	*3.64	*3.64	*3.31		*3.31	*3.31	8.07
2		R-Rear Dozer Only Up		*7.95	7.56	9.25	5.05	6.52	3.72	4.97	2.89	3.97	2.32	3.26	1.90			3.18	1.85	8.15
		R-Rear Dozer Only Down		*7.95	*7.95	9.05	6.85	6.37	4.94	4.85	3.80	3.87	3.05	3.19	2.51			3.10	2.44	8.15
		R-Outrigger Only Down		*7.95	*7.95	8.77	*9.73	6.17	7.41	4.70	5.58	3.74	4.42	3.08	3.63	2.99		*3.47	*3.47	8.15
		F-Dozer + R-Outrigger Down		*7.95	*7.95	*9.73	*9.73	*7.69	7.41	*6.53	5.58	*5.79	4.42	*4.19	3.63	*3.47		*3.47	*3.47	8.15
1		R-Rear Dozer Only Up		*5.99	*5.99	9.01	4.85	6.37	3.59	4.88	2.81	3.91	2.27	3.23	1.88			3.18	1.85	8.10
		R-Rear Dozer Only Down		*5.99	*5.99	8.81	6.63	6.23	4.80	4.76	3.72	3.82	2.99	3.16	2.48			3.10	2.44	8.10
		R-Outrigger Only Down		*5.99	*5.99	8.52	10.52	6.02	7.26	4.61	5.49	3.69	4.37	3.05	3.60	3.00		3.53	3.53	8.10
		F-Dozer + R-Outrigger Down		*5.99	*5.99	*10.84	10.52	*8.42	7.26	*7.00	5.49	*6.07	4.37	*4.27	3.60	*3.70		3.53	3.53	8.10



A (m) B (m)	Chassis Frame Attachment	2		3		4		5		6		7		8		Max. Reach		
																		
0	R-Rear Dozer Only Up			*6.94	*6.94	8.87	4.74	6.27	3.50	4.81	2.75	3.87	2.23			3.26	1.89	7.92
	R-Rear Dozer Only Down			*6.94	*6.94	8.67	6.50	6.13	4.71	4.70	3.65	3.78	2.95			3.18	2.50	7.92
	R-Outrigger Only Down			*6.94	*6.94	8.38	10.37	5.92	7.15	4.54	5.41	3.65	4.32			3.07	3.63	7.92
	F-Dozer + R-Outrigger Down			*6.94	*6.94	*11.39	10.37	*8.88	7.15	*7.31	5.41	*6.24	4.32			*4.04	3.63	7.92
-1	R-Rear Dozer Only Up	*5.59	*5.59	*8.94	7.15	8.81	4.69	6.22	3.46	4.77	2.71	3.85	2.21			3.44	1.99	7.60
	R-Rear Dozer Only Down	*5.59	*5.59	*8.94	*8.94	8.61	6.45	6.07	4.66	4.66	3.62	3.76	2.93			3.36	2.63	7.60
	R-Outrigger Only Down	*5.59	*5.59	*8.94	*8.94	8.32	10.3	5.87	7.09	4.50	5.37	3.63	4.30			3.24	3.84	7.60
	F-Dozer + R-Outrigger Down	*5.59	*5.59	*8.94	*8.94	*11.43	10.3	*9.01	7.09	*7.40	5.37	*6.23	4.30			*4.53	3.84	7.60
2	R-Rear Dozer Only Up	*8.07	*8.07	*11.79	7.18	8.81	4.69	6.20	3.45	4.76	2.71	3.85	2.22			3.77	2.17	7.13
	R-Rear Dozer Only Down	*8.07	*8.07	*11.79	10.35	8.61	6.45	6.06	4.65	4.65	3.61	3.76	2.94			3.68	2.88	7.13
	R-Outrigger Only Down	*8.07	*8.07	*11.79	*11.79	8.32	10.3	5.86	7.08	4.49	5.37	3.63	4.31			3.55	4.21	7.13
	F-Dozer + R-Outrigger Down	*8.07	*8.07	*11.79	*11.79	*11.02	10.3	*8.78	7.08	*7.19	5.37	*5.89	4.31			*5.30	4.21	7.13
-3	R-Rear Dozer Only Up	*11.05	*11.05	*12.98	7.26	8.86	4.73	6.24	3.47	4.79	2.73					4.34	2.49	6.46
	R-Rear Dozer Only Down	*11.05	*11.05	*12.98	10.44	8.66	6.50	6.09	4.68	4.68	3.64					4.24	3.31	6.46
	R-Outrigger Only Down	*11.05	*11.05	*12.98	*12.98	8.38	*10.12	5.89	7.11	4.52	5.40					4.09	4.87	6.46
	F-Dozer + R-Outrigger Down	*11.05	*11.05	*12.98	*12.98	*10.12	*10.12	*8.11	7.11	*6.53	5.40					*5.80	4.87	6.46
-4	R-Rear Dozer Only Up	*14.29	*14.29	*10.82	7.40	*8.54	4.82	6.32	3.55							5.47	3.12	5.53
	R-Rear Dozer Only Down	*14.29	*14.29	*10.82	10.6	*8.54	6.59	6.18	4.76							5.35	4.15	5.53
	R-Outrigger Only Down	*14.29	*14.29	*10.82	*10.82	8.48	*8.54	5.98	*6.73							5.17	*5.76	5.53
	F-Dozer + R-Outrigger Down	*14.29	*14.29	*10.82	*10.82	*8.54	*8.54	*6.73	*6.73							*5.76	*5.76	5.53
-5	R-Rear Dozer Only Up					*5.59	4.99									*5.29	4.75	4.15
	R-Rear Dozer Only Down					*5.59	*5.59									*5.29	*5.29	4.15
	R-Outrigger Only Down					*5.59	*5.59									*5.29	*5.29	4.15
	F-Dozer + R-Outrigger Down					*5.59	*5.59									*5.29	*5.29	4.15

## FEET (17' 1" One-Piece Boom, 10' 2" Arm)

A (ft) B (ft)	Chassis Frame Attachment	10		15		20		25		Max. Reach		
												A
25	R-Rear Dozer Only Up									*7.37	*7.37	18.77
	R-Rear Dozer Only Down									*7.37	*7.37	18.77
	R-Outrigger Only Down									*7.37	*7.37	18.77
	F-Dozer + R-Outrigger									*7.37	*7.37	18.77
20	R-Rear Dozer Only Up					*10.11	6.83			*6.96	5.50	22.81
	R-Rear Dozer Only Down					*10.11	8.84			*6.96	*6.96	22.81
	R-Outrigger Only Down					*10.11	*10.11			*6.96	*6.96	22.81
	F-Dozer + R-Outrigger					*10.11	*10.11			*6.96	*6.96	22.81
15	R-Rear Dozer Only Up					11.21	6.69	*7.54	4.70	*6.98	4.63	25.22
	R-Rear Dozer Only Down					10.97	8.68	*7.54	6.13	*6.98	6.04	25.22
	R-Outrigger Only Down					10.63	*11.44	7.49	*7.54	*6.98	*6.98	25.22
	F-Dozer + R-Outrigger					*11.44	*11.44	*7.54	*7.54	*6.98	*6.98	25.22
10	R-Rear Dozer Only Up	*23.62	17.52	*15.97	9.71	10.92	6.42	7.82	4.60	7.17	4.21	26.46
	R-Rear Dozer Only Down	*23.62	*23.62	*15.97	12.87	10.68	8.40	7.64	6.03	7.00	5.52	26.46
	R-Outrigger Only Down	*23.62	*23.62	*15.97	*15.97	10.34	12.24	7.38	8.70	6.77	*7.27	26.46
	F-Dozer + R-Outrigger	*23.62	*23.62	*15.97	*15.97	*13.01	12.24	*10.69	8.70	*7.27	*7.27	26.46
5	R-Rear Dozer Only Up	*15.04	*15.04	16.28	9.09	10.6	6.14	7.68	4.48	6.99	4.06	26.70
	R-Rear Dozer Only Down	*15.04	*15.04	15.91	12.20	10.36	8.10	7.50	5.90	6.82	5.36	26.70
	R-Outrigger Only Down	*15.04	*15.04	15.40	18.68	10.02	11.91	7.25	8.55	6.58	7.76	26.70
	F-Dozer + R-Outrigger	*15.04	*15.04	*19.55	18.68	*14.70	11.91	*12.25	8.55	*7.87	7.76	26.70
0 (GND)	R-Rear Dozer Only Up	*15.90	15.41	15.83	8.71	10.36	5.93	7.58	4.38	7.19	4.16	25.98
	R-Rear Dozer Only Down	*15.90	*15.90	15.46	11.79	10.12	7.88	7.40	5.80	7.02	5.50	25.98
	R-Outrigger Only Down	*15.90	*15.90	14.95	18.2	9.78	11.66	7.14	8.45	6.77	8.00	25.98
	F-Dozer + R-Outrigger	*15.90	*15.90	*21.60	18.2	*15.85	11.66	*12.61	8.45	*8.91	8.00	25.98
-5	R-Rear Dozer Only Up	*23.32	15.40	15.67	8.58	10.27	5.84			7.91	4.56	24.19
	R-Rear Dozer Only Down	*23.32	22.13	15.31	11.65	10.02	7.79			7.72	6.05	24.19
	R-Outrigger Only Down	*23.32	*23.32	14.80	18.04	9.68	11.56			7.46	8.83	24.19
	F-Dozer + R-Outrigger	*23.32	*23.32	*21.65	18.04	*15.88	11.56			*10.77	8.83	24.19
-10	R-Rear Dozer Only Up	*28.06	15.63	15.76	8.66	10.35	5.91			9.65	5.54	21.07
	R-Rear Dozer Only Down	*28.06	22.39	15.40	11.73	10.11	7.86			9.42	7.35	21.07
	R-Outrigger Only Down	*28.06	*28.06	14.89	18.13	9.77	11.64			9.10	10.82	21.07
	F-Dozer + R-Outrigger	*28.06	*28.06	*19.51	18.13	*13.95	11.64			*12.79	10.82	21.07
-15	R-Rear Dozer Only Up	*19.75	16.15	*13.41	9.00					*12.33	8.40	15.81
	R-Rear Dozer Only Down	*19.75	*19.75	*13.41	12.10					*12.33	11.25	15.81
	R-Outrigger Only Down	*19.75	*19.75	*13.41	*13.41					*12.33	*12.33	15.81
	F-Dozer + R-Outrigger	*19.75	*19.75	*13.41	*13.41					*12.33	*12.33	15.81

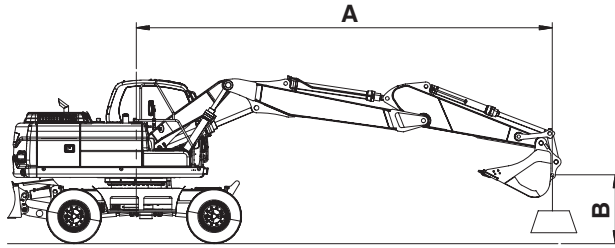
1. Ratings are based on SAE J1097.
2. Load point is the hook on the back of the bucket.
3. \* Rated loads are based on hydraulic capacity.
4. Rated loads do not exceed 87% of hyd. Capacity or 75% of tipping capacity.































Boom : 5.36 m (17' 7") Two-Piece Boom  
 Arm : 2.6 m (8' 6")  
 Bucket : Without Bucket  
 UNIT : 1000 kg (1000 lb)  
 : Rated lift capacity - over front  
 (Free on wheel /  
 Dozer and outrigger on ground)  
 : Rated lift capacity - over side  
 (Free on wheel /  
 Dozer and outrigger on ground)

FG008695











Figure 51

**METRIC (5.36 m Two-Piece Boom, 2.6 m Arm)**

A (m) \ B (m)	Chassis Frame Attachment	3		4		5		6		7		8		Max. Reach		A
																
9	R-Rear Dozer Only Up													*4.03	*4.03	3.67
	R-Rear Dozer Only Down													*4.03	*4.03	3.67
	R-Outrigger Only Down													*4.03	*4.03	3.67
	F-Dozer + R-Outrigger Down													*4.03	*4.03	3.67
8	R-Rear Dozer Only Up					*4.47	4.15							*3.22	*3.22	5.22
	R-Rear Dozer Only Down					*4.47	*4.47							*3.22	*3.22	5.22
	R-Outrigger Only Down					*4.47	*4.47							*3.22	*3.22	5.22
	F-Dozer + R-Outrigger Down					*4.47	*4.47							*3.22	*3.22	5.22
7	R-Rear Dozer Only Up					*4.18	*4.18	*4.31	3.16					*2.89	*2.89	6.23
	R-Rear Dozer Only Down					*4.18	*4.18	*4.31	4.09					*2.89	*2.89	6.23
	R-Outrigger Only Down					*4.18	*4.18	*4.31	*4.31					*2.89	*2.89	6.23
	F-Dozer + R-Outrigger Down					*4.18	*4.18	*4.31	*4.31					*2.89	*2.89	6.23
6	R-Rear Dozer Only Up					*4.29	4.19	*4.45	3.18					*2.72	2.50	6.95
	R-Rear Dozer Only Down					*4.29	*4.29	*4.45	4.11					*2.72	*2.72	6.95
	R-Outrigger Only Down					*4.29	*4.29	*4.45	*4.45					*2.72	*2.72	6.95
	F-Dozer + R-Outrigger Down					*4.29	*4.29	*4.45	*4.45					*2.72	*2.72	6.95
5	R-Rear Dozer Only Up			*5.00	*5.00	*4.78	4.11	*4.67	3.14	4.14	2.48			*2.63	2.23	7.47
	R-Rear Dozer Only Down			*5.00	*5.00	*4.78	*4.78	*4.67	4.07	4.05	3.22			*2.63	*2.63	7.47
	R-Outrigger Only Down			*5.00	*5.00	*4.78	*4.78	*4.67	*4.67	3.92	4.61			*2.63	*2.63	7.47
	F-Dozer + R-Outrigger Down			*5.00	*5.00	*4.78	*4.78	*4.67	*4.67	*4.72	4.61			*2.63	*2.63	7.47
4	R-Rear Dozer Only Up			*6.36	5.51	*5.54	4.00	*5.11	3.08	4.11	2.46			*2.60	2.06	7.81
	R-Rear Dozer Only Down			*6.36	*6.36	*5.54	5.24	5.07	4.01	4.02	3.19			*2.60	*2.60	7.81
	R-Outrigger Only Down			*6.36	*6.36	*5.54	*5.54	4.91	*5.11	3.89	4.58			*2.60	*2.60	7.81
	F-Dozer + R-Outrigger Down			*6.36	*6.36	*5.54	*5.54	*5.11	*5.11	*4.91	4.58			*2.60	*2.60	7.81
3	R-Rear Dozer Only Up			*8.04	5.26	*6.48	3.87	5.09	3.01	4.07	2.42	*2.91	1.98	*2.61	1.97	8.02
	R-Rear Dozer Only Down			*8.04	7.07	*6.48	5.10	4.98	3.92	3.98	3.15	*2.91	2.58	*2.61	2.57	8.02
	R-Outrigger Only Down			*8.04	*8.04	6.34	*6.48	4.82	*5.67	3.85	4.53	*2.91	*2.91	*2.61	*2.61	8.02
	F-Dozer + R-Outrigger Down			*8.04	*8.04	*6.48	*6.48	*5.67	*5.67	*5.23	4.53	*2.91	*2.91	*2.61	*2.61	8.02
2	R-Rear Dozer Only Up			9.23	5.04	6.54	3.74	5.01	2.93	4.02	2.37	3.32	1.96	*2.66	1.93	8.10
	R-Rear Dozer Only Down			9.02	6.83	6.39	4.96	4.9	3.84	3.93	3.10	3.24	2.56	*2.66	2.52	8.10
	R-Outrigger Only Down			8.74	*9.64	6.19	*7.43	4.74	5.62	3.80	4.48	3.13	3.68	*2.66	*2.66	8.10
	F-Dozer + R-Outrigger Down			*9.64	*9.64	*7.43	*7.43	*6.26	5.62	*5.60	4.48	*3.82	3.68	*2.66	*2.66	8.10



A (m) B (m)	Chassis Frame Attachment	3		4		5		6		7		8		Max. Reach		A
																
1	R-Rear Dozer Only Up			9.06	4.90	6.43	3.65	4.94	2.87	3.98	2.33	3.30	1.95	*2.75	1.93	8.05
	R-Rear Dozer Only Down			8.86	6.68	6.28	4.86	4.83	3.78	3.88	3.06	3.23	2.55	*2.75	2.53	8.05
	R-Outrigger Only Down			8.58	10.57	6.08	7.32	4.67	5.55	3.76	4.43	3.12	*3.44	*2.75	*2.75	8.05
	F-Dozer + R-Outrigger Down			*10.68	10.57	*8.23	7.32	*6.81	5.55	*5.95	4.43	*3.44	*3.44	*2.75	*2.75	8.05
0	R-Rear Dozer Only Up			8.99	4.84	6.36	3.59	4.89	2.83	3.95	2.31			*2.89	1.98	7.87
	R-Rear Dozer Only Down			8.78	6.61	6.22	4.80	4.78	3.73	3.86	3.03			*2.89	2.60	7.87
	R-Outrigger Only Down			8.50	10.49	6.01	7.24	4.62	5.50	3.73	4.40			*2.89	*2.89	7.87
	F-Dozer + R-Outrigger Down			*11.29	10.49	*8.79	7.24	*7.23	5.50	*6.23	4.40			*2.89	*2.89	7.87
-1	R-Rear Dozer Only Up	*6.81	*6.81	8.97	4.83	6.33	3.56	4.87	2.81	3.94	2.30			*3.10	2.10	7.55
	R-Rear Dozer Only Down	*6.81	*6.81	8.77	6.60	6.19	4.77	4.76	3.71	3.85	3.03			*3.10	2.75	7.55
	R-Outrigger Only Down	*6.81	*6.81	8.48	10.47	5.99	7.21	4.60	5.48	3.72	4.40			*3.10	*3.10	7.55
	F-Dozer + R-Outrigger Down	*6.81	*6.81	*11.60	10.47	*9.08	7.21	*7.47	5.48	*6.36	4.40			*3.10	*3.10	7.55
2	R-Rear Dozer Only Up	*10.44	7.44	9.00	4.85	6.34	3.57	4.88	2.81	3.97	2.33			*3.42	2.30	7.07
	R-Rear Dozer Only Down	*10.44	*10.44	8.80	6.62	6.20	4.78	4.77	3.72	3.88	3.05			*3.42	3.02	7.07
	R-Outrigger Only Down	*10.44	*10.44	8.51	10.50	6.00	7.22	4.61	5.49	3.75	4.43			*3.42	*3.42	7.07
	F-Dozer + R-Outrigger Down	*10.44	*10.44	*11.44	10.50	*9.08	7.22	*7.46	5.49	*4.71	4.43			*3.42	*3.42	7.07
-3	R-Rear Dozer Only Up			9.07	4.91	6.39	3.61	4.93	2.86					4.83	2.81	6.10
	R-Rear Dozer Only Down			8.86	6.69	6.24	4.82	4.82	3.77					4.72	3.69	6.10
	R-Outrigger Only Down			8.58	10.58	6.04	7.27	4.66	5.54					4.56	5.42	6.10
	F-Dozer + R-Outrigger Down			*10.86	10.58	*8.67	7.27	*6.98	5.54					*6.82	5.42	6.10

## FEET (17' 7" One-Piece Boom, 8' 6" Arm)

A (ft) B (ft)	Chassis Frame Attachment	10		15		20		25		Max. Reach		A
												
25	R-Rear Dozer Only Up			*9.16	*9.16					*6.75	*6.75	18.54
	R-Rear Dozer Only Down			*9.16	*9.16					*6.75	*6.75	18.54
	R-Outrigger Only Down			*9.16	*9.16					*6.75	*6.75	18.54
	F-Dozer + R-Outrigger			*9.16	*9.16					*6.75	*6.75	18.54
20	R-Rear Dozer Only Up			*9.24	*9.24	*9.85	6.84			*6.02	5.58	22.62
	R-Rear Dozer Only Down			*9.24	*9.24	*9.85	8.84			*6.02	*6.02	22.62
	R-Outrigger Only Down			*9.24	*9.24	*9.85	*9.85			*6.02	*6.02	22.62
	F-Dozer + R-Outrigger			*9.24	*9.24	*9.85	*9.85			*6.02	*6.02	22.62
15	R-Rear Dozer Only Up			*11.54	10.22	*10.63	6.72	*6.15	4.75	*5.76	4.73	25.04
	R-Rear Dozer Only Down			*11.54	*11.54	*10.63	8.71	*6.15	*6.15	*5.76	*5.76	25.04
	R-Outrigger Only Down			*11.54	*11.54	*10.63	*10.63	*6.15	*6.15	*5.76	*5.76	25.04
	F-Dozer + R-Outrigger			*11.54	*11.54	*10.63	*10.63	*6.15	*6.15	*5.76	*5.76	25.04
10	R-Rear Dozer Only Up			*15.34	9.66	10.98	6.49	7.92	4.70	*5.75	4.35	26.30
	R-Rear Dozer Only Down			*15.34	12.81	10.74	8.47	7.74	6.13	*5.75	5.67	26.30
	R-Outrigger Only Down			*15.34	*15.34	10.40	12.3	7.49	8.80	*5.75	*5.75	26.30
	F-Dozer + R-Outrigger			*15.34	*15.34	*12.31	12.3	*11.21	8.80	*5.75	*5.75	26.30
5	R-Rear Dozer Only Up			16.34	9.16	10.72	6.26	7.82	4.61	*5.94	4.24	26.54
	R-Rear Dozer Only Down			15.98	12.27	10.48	8.22	7.64	6.03	*5.94	5.55	26.54
	R-Outrigger Only Down			15.47	18.75	10.14	12.03	7.38	8.69	*5.94	*5.94	26.54
	F-Dozer + R-Outrigger			*19.13	18.75	*14.20	12.03	*12.06	8.69	*5.94	*5.94	26.54
0 (GND)	R-Rear Dozer Only Up			16.04	8.91	10.54	6.10	7.76	4.55	*6.36	4.37	25.81
	R-Rear Dozer Only Down			15.68	11.99	10.30	8.06	7.58	5.97	*6.36	5.73	25.81
	R-Outrigger Only Down			15.17	18.42	9.96	11.84	7.32	8.63	*6.36	*6.36	25.81
	F-Dozer + R-Outrigger			*21.47	18.42	*15.68	11.84	*12.66	8.63	*6.36	*6.36	25.81
-5	R-Rear Dozer Only Up	*19.43	15.93	15.99	8.86	10.50	6.06			*7.16	4.83	24.01
	R-Rear Dozer Only Down	*19.43	*19.43	15.63	11.95	10.26	8.01			*7.16	6.34	24.01
	R-Outrigger Only Down	*19.43	*19.43	15.12	18.37	9.92	11.8			*7.16	*7.16	24.01
	F-Dozer + R-Outrigger	*19.43	*19.43	*22.13	18.37	*16.25	11.8			*7.16	*7.16	24.01
-10	R-Rear Dozer Only Up			16.14	8.99					10.88	6.31	19.68
	R-Rear Dozer Only Down			15.78	12.09					10.63	8.32	19.68
	R-Outrigger Only Down			15.27	18.53					10.28	12.22	19.68
	F-Dozer + R-Outrigger			*20.91	18.53					*15.30	12.22	19.68

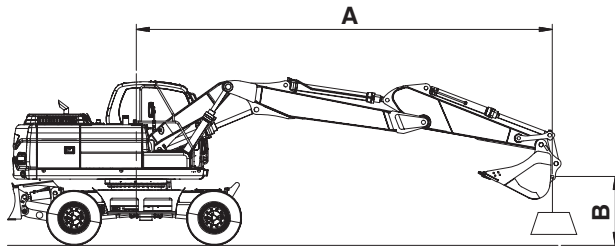
1. Ratings are based on SAE J1097.
2. Load point is the hook on the back of the bucket.
3. \* Rated loads are based on hydraulic capacity.
4. Rated loads do not exceed 87% of hyd. Capacity or 75% of tipping capacity.































Boom : 5.36 m (17' 7") Two-Piece Boom  
 Arm : 2.3 m (7' 7")  
 Bucket : Without Bucket  
 Attachment : Front clamshell cradle  
 & rear dozer blade  
 UNIT : 1000 kg (1000 lb)  
 : Rated lift capacity - over front  
 (Free on wheel /  
 Dozer and outrigger on ground)  
 : Rated lift capacity - over side  
 (Free on wheel /  
 Dozer and outrigger on ground)

FG008696











Figure 52

**METRIC (5.36 m Two-Piece Boom, 2.3 m Arm)**

A (m) B (m)	Chassis Frame Attachment	3		4		5		6		7		8		Max. Reach		A
																
8	R-Rear Dozer Only Up													*3.49	*3.49	4.74
	R-Rear Dozer Only Down													*3.49	*3.49	4.74
	R-Outrigger Only Down													*3.49	*3.49	4.74
	F-Dozer + R-Outrigger Down													*3.49	*3.49	4.74
7	R-Rear Dozer Only Up					*4.58	4.16							*3.08	*3.08	5.84
	R-Rear Dozer Only Down					*4.58	*4.58							*3.08	*3.08	5.84
	R-Outrigger Only Down					*4.58	*4.58							*3.08	*3.08	5.84
	F-Dozer + R-Outrigger Down					*4.58	*4.58							*3.08	*3.08	5.84
6	R-Rear Dozer Only Up					*4.63	4.14	*4.77	3.13					*2.89	2.67	6.60
	R-Rear Dozer Only Down					*4.63	*4.63	*4.77	4.06					*2.89	*2.89	6.60
	R-Outrigger Only Down					*4.63	*4.63	*4.77	*4.77					*2.89	*2.89	6.60
	F-Dozer + R-Outrigger Down					*4.63	*4.63	*4.77	*4.77					*2.89	*2.89	6.60
5	R-Rear Dozer Only Up			*5.47	*5.47	*5.10	4.07	*4.93	3.11	4.10	2.44			*2.79	2.36	7.14
	R-Rear Dozer Only Down			*5.47	*5.47	*5.10	*5.10	*4.93	4.03	4.01	3.18			*2.79	*2.79	7.14
	R-Outrigger Only Down			*5.47	*5.47	*5.10	*5.10	*4.93	*4.93	3.88	*4.26			*2.79	*2.79	7.14
	F-Dozer + R-Outrigger Down			*5.47	*5.47	*5.10	*5.10	*4.93	*4.93	*4.26	*4.26			*2.79	*2.79	7.14
4	R-Rear Dozer Only Up			*6.86	5.43	*5.86	3.95	5.14	3.05	4.08	2.43			*2.76	2.17	7.51
	R-Rear Dozer Only Down			*6.86	*6.86	*5.86	5.19	5.03	3.97	3.99	3.16			*2.76	*2.76	7.51
	R-Outrigger Only Down			*6.86	*6.86	*5.86	*5.86	4.87	*5.34	3.86	4.54			*2.76	*2.76	7.51
	F-Dozer + R-Outrigger Down			*6.86	*6.86	*5.86	*5.86	*5.34	*5.34	*5.13	4.54			*2.76	*2.76	7.51
3	R-Rear Dozer Only Up			*8.55	5.18	6.63	3.82	5.06	2.97	4.04	2.39			*2.77	2.06	7.72
	R-Rear Dozer Only Down			*8.55	6.99	6.49	5.05	4.95	3.89	3.95	3.12			*2.77	2.70	7.72
	R-Outrigger Only Down			*8.55	*8.55	6.28	*6.78	4.79	5.67	3.82	4.50			*2.77	*2.77	7.72
	F-Dozer + R-Outrigger Down			*8.55	*8.55	*6.78	*6.78	*5.88	5.67	*5.41	4.50			*2.77	*2.77	7.72
2	R-Rear Dozer Only Up			9.15	4.98	6.49	3.70	4.98	2.90	4.00	2.35			*2.82	2.01	7.80
	R-Rear Dozer Only Down			8.95	6.76	6.35	4.92	4.87	3.82	3.91	3.08			*2.82	2.64	7.80
	R-Outrigger Only Down			8.66	*10.08	6.15	7.39	4.71	5.59	3.78	4.46			*2.82	*2.82	7.80
	F-Dozer + R-Outrigger Down			*10.08	*10.08	*7.68	7.39	*6.44	5.59	*5.75	4.46			*2.82	*2.82	7.80
1	R-Rear Dozer Only Up			9.01	4.86	6.40	3.62	4.92	2.85	3.96	2.32			*2.92	2.02	7.75
	R-Rear Dozer Only Down			8.81	6.64	6.25	4.83	4.80	3.76	3.87	3.04			*2.92	2.65	7.75
	R-Outrigger Only Down			8.53	*9.51	6.05	7.28	4.65	5.53	3.74	4.42			*2.92	*2.92	7.75
	F-Dozer + R-Outrigger Down			*9.51	*9.51	*8.42	7.28	*6.95	5.53	*6.06	4.42			*2.92	*2.92	7.75

A (m) B (m)	Chassis Frame Attachment	3		4		5		6		7		8		Max. Reach		
																A
0	R-Rear Dozer Only Up			8.96	4.82	6.34	3.57	4.88	2.81	3.94	2.30			*3.08	2.08	7.56
	R-Rear Dozer Only Down			8.76	6.59	6.20	4.78	4.76	3.72	3.85	3.02			*3.08	2.74	7.56
	R-Outrigger Only Down			8.48	10.47	5.99	7.22	4.61	5.48	3.72	4.40			*3.08	*3.08	7.56
	F-Dozer + R-Outrigger Down			*11.13	10.47	*8.90	7.22	*7.32	5.48	*6.29	4.40			*3.08	*3.08	7.56
-1	R-Rear Dozer Only Up	*7.07	*7.07	8.97	4.82	6.32	3.56	4.86	2.80	3.94	2.30			*3.32	2.22	7.23
	R-Rear Dozer Only Down	*7.07	*7.07	8.76	6.60	6.18	4.76	4.75	3.71	3.85	3.03			*3.32	2.91	7.23
	R-Outrigger Only Down	*7.07	*7.07	8.48	10.47	5.98	7.21	4.59	5.47	3.72	4.40			*3.32	*3.32	7.23
	F-Dozer + R-Outrigger Down	*7.07	*7.07	*11.57	10.47	*9.11	7.21	*7.49	5.47	*6.33	4.40			*3.32	*3.32	7.23
2	R-Rear Dozer Only Up	*11.45	7.46	9.01	4.86	6.34	3.57	4.88	2.82					*3.70	2.46	6.73
	R-Rear Dozer Only Down	*11.45	10.67	8.80	6.63	6.20	4.78	4.77	3.73					*3.70	3.23	6.73
	R-Outrigger Only Down	*11.45	*11.45	8.52	10.51	6.00	7.23	4.61	5.49					*3.70	*3.70	6.73
	F-Dozer + R-Outrigger Down	*11.45	*11.45	*11.29	10.51	*9.00	7.23	*7.37	5.49					*3.70	*3.70	6.73

## FEET (17' 7" Two-Piece Boom, 7' 7" Arm)

A (ft) B (ft)	Chassis Frame Attachment	10		15		20		25		Max. Reach		
												A
25	R-Rear Dozer Only Up			*10.26	*10.26					*7.27	*7.27	17.09
	R-Rear Dozer Only Down			*10.26	*10.26					*7.27	*7.27	17.09
	R-Outrigger Only Down			*10.26	*10.26					*7.27	*7.27	17.09
	F-Dozer + R-Outrigger			*10.26	*10.26					*7.27	*7.27	17.09
20	R-Rear Dozer Only Up			*10.07	*10.07	*10.59	6.74			*6.40	5.98	21.46
	R-Rear Dozer Only Down			*10.07	*10.07	*10.59	8.73			*6.40	*6.40	21.46
	R-Outrigger Only Down			*10.07	*10.07	*10.59	*10.59			*6.40	*6.40	21.46
	F-Dozer + R-Outrigger			*10.07	*10.07	*10.59	*10.59			*6.40	*6.40	21.46
15	R-Rear Dozer Only Up	*15.84	*15.84	*12.36	10.09	11.15	6.64			*6.11	4.99	24.01
	R-Rear Dozer Only Down	*15.84	*15.84	*12.36	*12.36	10.91	8.63			*6.11	*6.11	24.01
	R-Outrigger Only Down	*15.84	*15.84	*12.36	*12.36	10.57	*11.17			*6.11	*6.11	24.01
	F-Dozer + R-Outrigger	*15.84	*15.84	*12.36	*12.36	*11.17	*11.17			*6.11	*6.11	24.01
10	R-Rear Dozer Only Up			*16.14	9.54	10.91	6.42	7.86	4.65	*6.10	4.55	25.31
	R-Rear Dozer Only Down			*16.14	12.68	10.66	8.40	7.68	6.07	*6.10	5.95	25.31
	R-Outrigger Only Down			15.91	*16.14	10.32	12.22	7.42	8.73	*6.10	*6.10	25.31
	F-Dozer + R-Outrigger			*16.14	*16.14	*12.77	12.22	*8.92	8.73	*6.10	*6.10	25.31
5	R-Rear Dozer Only Up			16.24	9.07	10.66	6.20	7.78	4.58	*6.31	4.43	25.57
	R-Rear Dozer Only Down			15.88	12.18	10.42	8.17	7.60	6.00	*6.31	5.81	25.57
	R-Outrigger Only Down			15.37	18.64	10.08	11.97	7.35	8.65	*6.31	*6.31	25.57
	F-Dozer + R-Outrigger			*19.73	18.64	*14.55	11.97	*11.35	8.65	*6.31	*6.31	25.57
0 (GND)	R-Rear Dozer Only Up			15.99	8.86	10.51	6.07			*6.80	4.59	24.81
	R-Rear Dozer Only Down			15.63	11.95	10.27	8.02			*6.80	6.03	24.81
	R-Outrigger Only Down			15.12	18.37	9.93	11.81			*6.80	*6.80	24.81
	F-Dozer + R-Outrigger			*21.73	18.37	*15.87	11.81			*6.80	*6.80	24.81
-5	R-Rear Dozer Only Up	*20.88	15.98	15.99	8.86	10.50	6.06			*7.72	5.13	22.93
	R-Rear Dozer Only Down	*20.88	*20.88	15.62	11.94	10.26	8.01			*7.72	6.73	22.93
	R-Outrigger Only Down	*20.88	*20.88	15.12	18.37	9.92	11.80			*7.72	*7.72	22.93
	F-Dozer + R-Outrigger	*20.88	*20.88	*22.04	18.37	*16.19	11.80			*7.72	*7.72	22.93

1. Ratings are based on SAE J1097.
2. Load point is the hook on the back of the bucket.
3. \* Rated loads are based on hydraulic capacity.
4. Rated loads do not exceed 87% of hyd. Capacity or 75% of tipping capacity.

# Operating Controls

The "Operating Controls" section presented here consists of the following groups:

1. "Component Locations" on page 2-4
2. "Operator's Area" on page 2-6
3. "Operational Controls and Panels" on page 2-8
4. "Instrument Panel" on page 2-26
5. "Multifunction Gauge and Graphic Information" on page 2-32
6. "Mode Selector Buttons" on page 2-38
7. "Setting Main Menu" on page 2-40
8. "Flow Control" on page 2-49
9. "Operation Selection Display" on page 2-51
10. "Heater and Air Conditioner Control Panel" on page 2-53
11. "Stereo" on page 2-59
12. "Miscellaneous Electrical Devices" on page 2-61
13. "Seat Adjustment" on page 2-63
14. "Ceiling Cover" on page 2-67
15. "Front Windows" on page 2-68
16. "Door Side Latch" on page 2-70
17. "Cabin Storage Compartments" on page 2-71
18. "Ashtray" on page 2-71
19. "Sun Visor" on page 2-72
20. "Hanger" on page 2-72
21. "Cup Holder" on page 2-73
22. "Door Window Holder" on page 2-73
23. "Emergency Glass Breaking Tool" on page 2-73
24. "Miscellaneous Access Covers and Doors" on page 2-74
25. "Swing Lock Pin and Mechanism" on page 2-76
26. "Wheel Chocks" on page 2-76

Each group is explained with a point location drawing or photo and a brief description of each control, switch, gauge or valve.

Indicator lights work besides the gauges on the instrument panel. The operator should monitor machine pressure on the instrument panel along with indicator lights. These lights will only show that there is a problem.

---

 **WARNING!**

---

**Warning lights. When any one or more of the warning lights on the control console, comes "ON," immediately stop operation and shut down unit. Investigate and correct the problem before proceeding with operation.**

---



# COMPONENT LOCATIONS

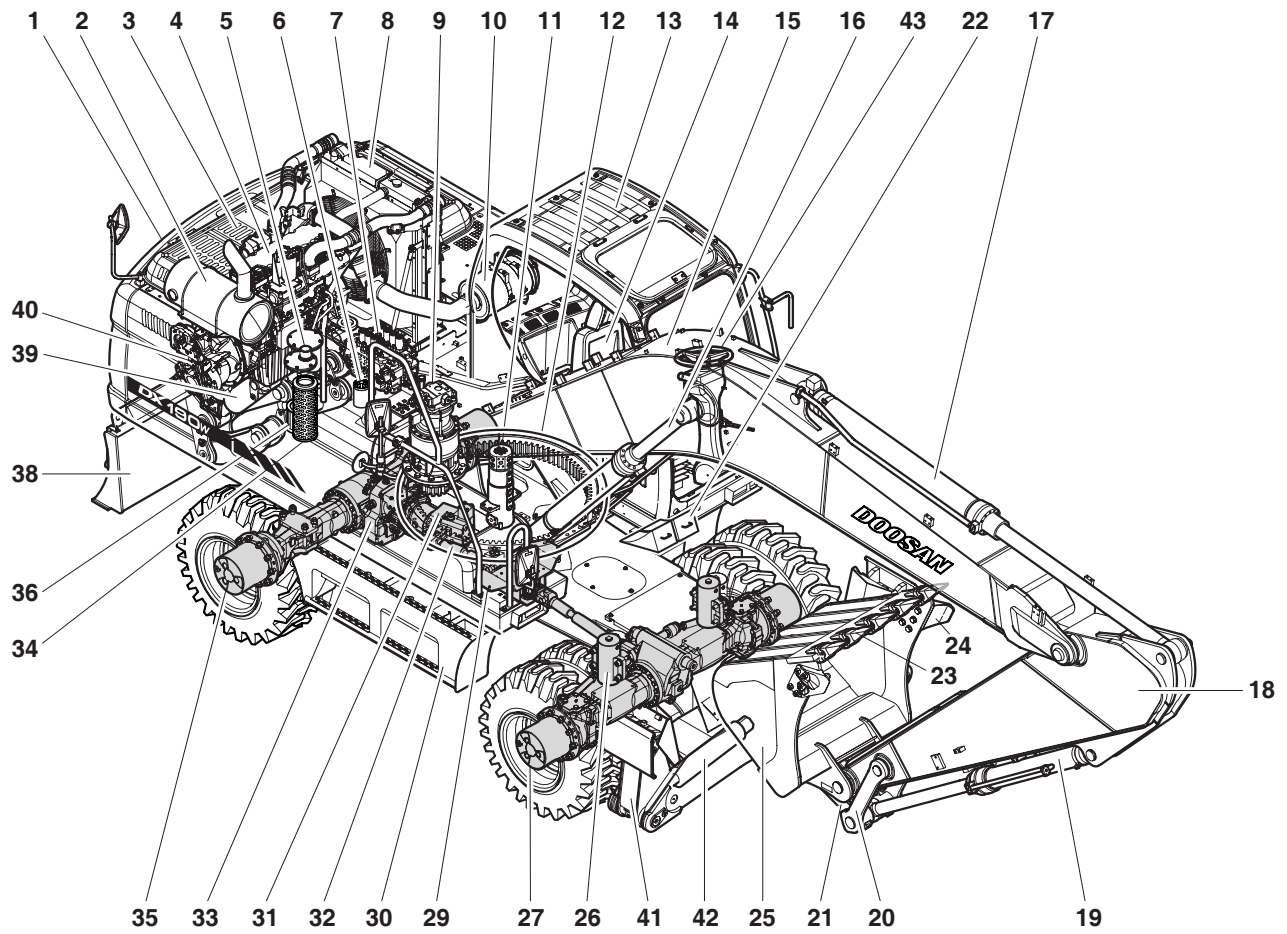

FG008697

Figure 1

Reference Number	Description
1	Counterweight
2	Muffler
3	Engine Cover
4	Engine
5	Hydraulic Oil Tank
6	Fuel Tank
7	Control Valve
8	Radiator And Oil Cooler
9	Swing Motor
10	Air Cleaner
11	Swivel Joint
12	Swing Bearing
13	Cabin
14	Seat
15	Boom
16	Boom Cylinder
17	Arm Cylinder
18	Arm
19	Bucket Cylinder
20	Guide Link
21	Push Link

Reference Number	Description
22	Wheel Chocks
23	Bucket Tooth
24	Side Cutter
25	Bucket
26	Ram Cylinders
27	Front Axle
29	Swing Lock
30	Step
31	Travel Motor
32	Propeller Shaft
33	Transmission
34	Return Filter
35	Rear Axle
36	Strainer
38	Dozer Blade
39	Dozer Blade Cylinders
40	Pumps
41	Outrigger
42	Outrigger Cylinder
43	Steering Column

# OPERATOR'S AREA

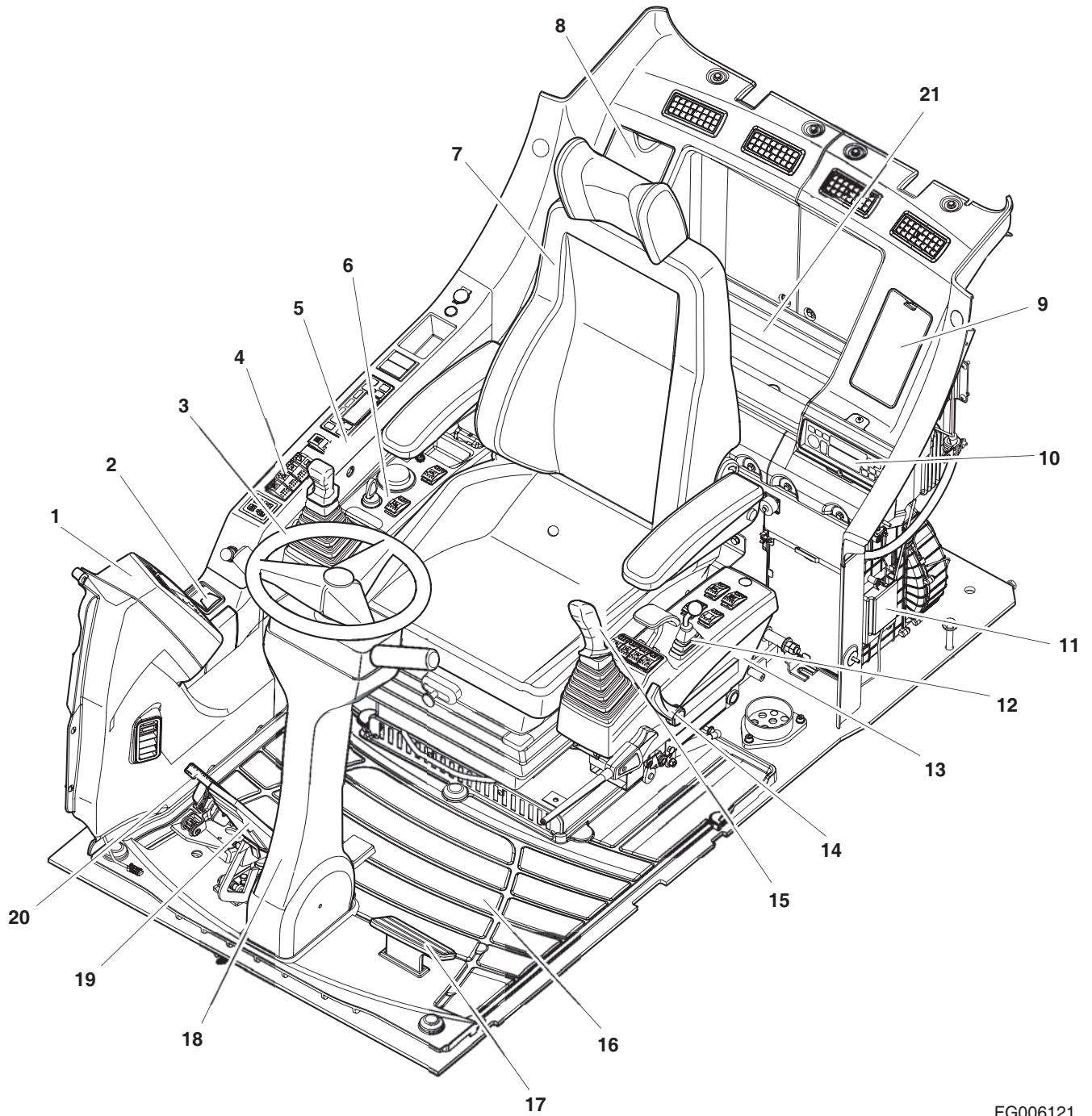

Figure 2

FG006121

Reference Number	Description
1	Instrument Panel (See page 2-26)
2	Ashtray (See page 2-71)
3	Steering Handle (See page 2-18)
4	Switch Panel (See page 2-8)
5	Right-hand Work Lever (Joystick) (See page 3-27)
6	Right-Control Stand (See page 2-8)
7	Seat (See page 2-63)
8	Storage Compartment (See page 2-71)
9	Fuse Box (See page 2-62)

Reference Number	Description
10	Stereo (See page 2-59)
11	Heater and Air Conditioner Unit
12	Dozer Blade Work Lever
13	Left-Control Stand (See page 2-8)
14	Left-Stand Tilting Lever (See page 3-14)
15	Left-hand Work Lever (Joystick) (See page 3-27)
16	Floor Mat
17	Foot Rest
18	Steering Column
19	Brake Pedal (See page 3-24)
20	Accelerator Pedal (See page 3-24)
21	Electric Box

# OPERATIONAL CONTROLS AND PANELS

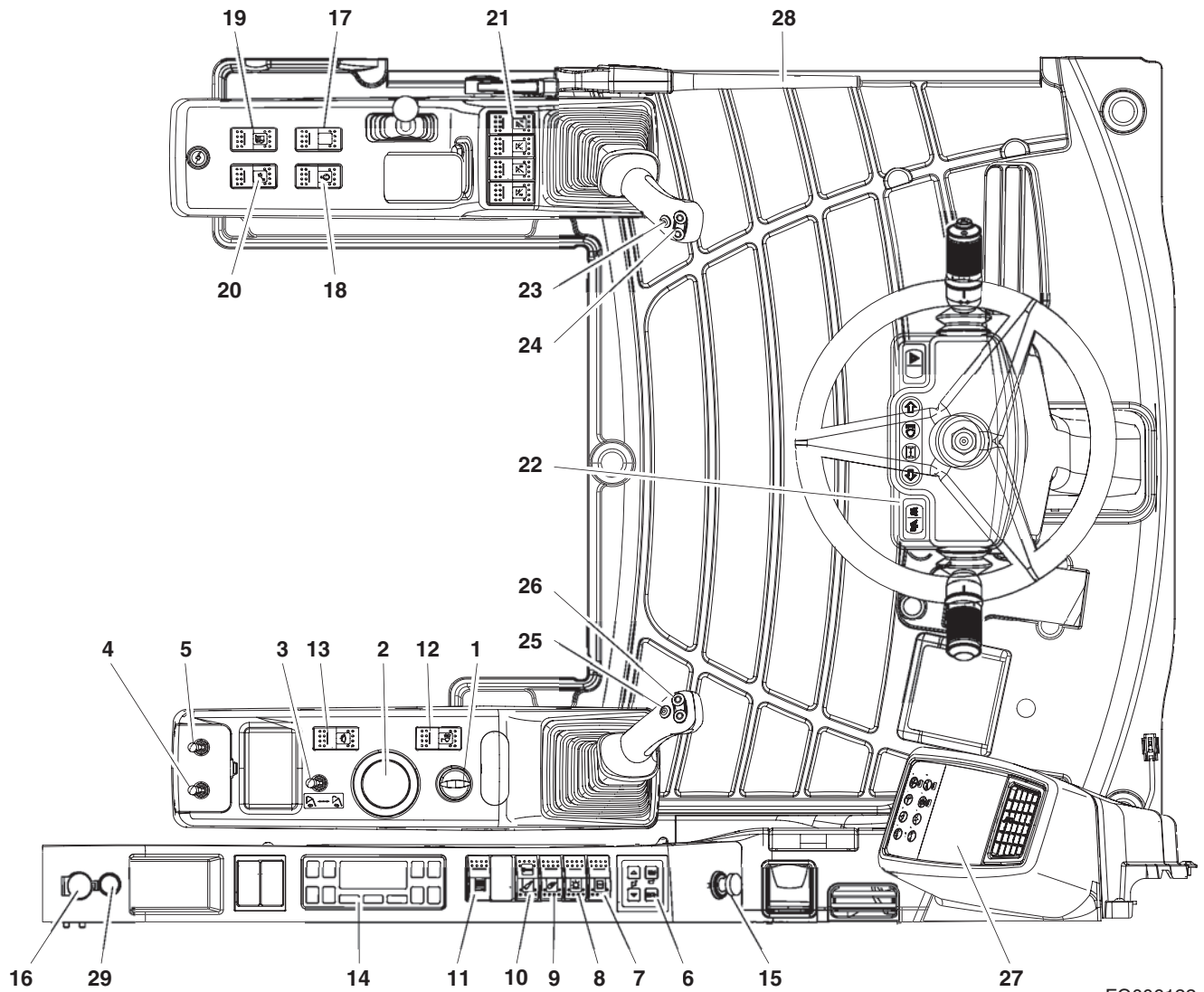

FG006122

Figure 3

Reference Number	Description
1	Starter Switch
2	Engine Speed Control Dial
3	Quick Clamp Switch (Optional)
4	Auxiliary Mode Switch
5	Emergency Stop Switch
6	Audio Control Panel
7	Ram Lock Switch
8	Light Switch
9	Work Light Switch
10	Breaker / Booster / Shear Selector Switch
11	Parking Brake Switch
12	Cabin Work Light Switch (Optional)
13	Lower Wiper Switch (Optional)
14	Heater and Air Conditional Control Panel

Reference Number	Description
15	Cigarette Lighter
16	Power Socket For 12V
17	Warning Light Switch (Optional)
18	Overload Warning Switch (Optional)
19	Fuel Heater Switch (Optional)
20	Seat Warmer Switch (Optional)
21	Outrigger Selection Switch
22	Steering Console
23	Horn Button
24	Rotating Switch
25	Breaker/Booster Switch
26	Shear Switch
27	Instrument Panel
28	Safety Lever
29	Photo Sensor

## 1. Starter Switch

A three-position starter switch is used to start or shut down engine for equipment operation.

- O. Turning the switch to this position turns the engine "OFF" along with its electrical system. In this position the engine is "OFF" but the interior cabin light and fuel tank transfer pump (if equipped) are functional.
- I. Turning the switch to this position turns the engine electrical system "ON." When the switch is first turned "ON" the six indicator/warning lights across the top of the instrument panel, will light for approximately two seconds. The battery warning light and the engine oil pressure warning light should remain "ON" after the other four have turned "OFF."

**NOTE:** *Preheat Indicator Light - The operation of the preheat cycle depends on coolant temperature. When the engine coolant is cold enough, the preheat indicator light will remain "ON" until the engine preheat cycle is completed. The preheat cycle takes about twenty seconds to complete, and the indicator light will turn "OFF." When the light turns "OFF," engage the starter.*

- Ⓞ. Moving switch to this position will crank engine. When engine starts, release key and allow it to return to the "I" (ON) position. Do not operate the starter switch for more than fifteen seconds at a time. This will help prevent damage to starter.

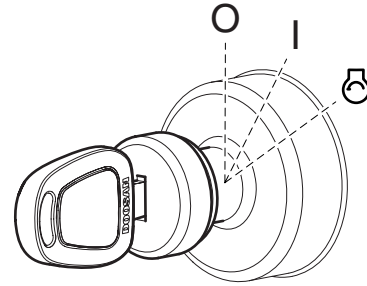

Figure 4

FG000014



## WARNING!

**DO NOT USE STARTING FLUIDS.** The preheat system could cause the starting fluid to explode. Starting fluids should never be used.

## 2. Engine Speed Control Dial

The engine speed is controlled by the dial. Rotating it clockwise increases engine speed (rpm) and counterclockwise decreases engine speed.

- A. Low idle (Lowest engine speed)
- B. High idle (Highest engine speed)

**NOTE:** *The auto idle system will automatically reduce engine speed to idle speed approximately four seconds after all of the control levers are in the neutral position. This system is designed to reduce fuel consumption and noise. See "3. Auto Idle Selector Button" on page 2-39.*

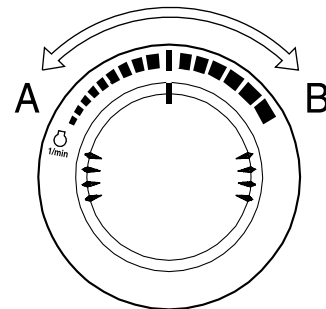



Figure 5

HAOA690L

### 3. Quick Clamp Switch (Optional)

Clamp releasing for dispensable attachment is controlled.

- O. In this position , the quick clamp is "LOCKED." The attachment is secured to the arm.
- I. In this position , the quick clamp is "UNLOCKED." The attachment is released from the arm.

**NOTE:** To move the switch, pull up on the toggle and then move it into the "UNLOCKED" position.

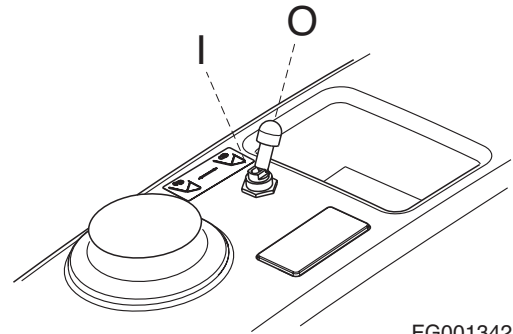

FG001342

Figure 6



## WARNING!

When the attachment is still connected to the machine, while the switch is "I" () position, do not operate the machine or the attachment might fall to the ground. It would cause personnel injuries.

### 4. Auxiliary Mode Switch

When the control system is out of order, the pump system can be controlled manually.

- O. In this position, the manual pump control is "OFF."
- I. In this position, the manual pump control is "ON."



## CAUTION!

Be sure to turn pump control to the "O" (OFF) position, after the control system is operating properly.

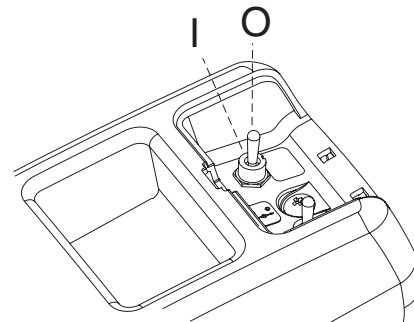

FG001343

Figure 7

### 5. Engine Emergency Stop Switch

If the engine does not shut down when using the starter switch, it can be stopped by moving the engine emergency stop switch to the "I" (EMERGENCY STOP) position.

- O. In this position, the engine emergency stop system is "OFF."
- I. In this position, "EMERGENCY STOP" is selected. The engine will shut down.

**NOTE:** When released, the switch will return to its original position "O" (OFF) position.

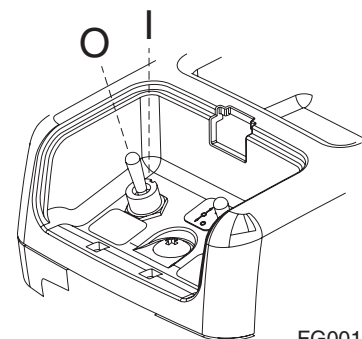

FG001344

Figure 8

## 6. Audio Control Panel

The audio system can be remotely controlled using this panel.

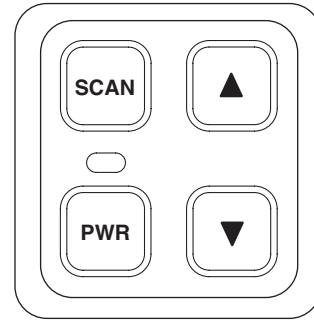

FG000018

Figure 9

Each time this power button is pressed, the audio system is turned either "ON" or "OFF."

If the audio system turns "ON," an indicator light above the button turns "ON."



FG000019

Figure 10

Press the up button, to "INCREASE" volume.

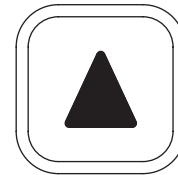

FG000020

Figure 11

Press the down button, to "DECREASE" volume.

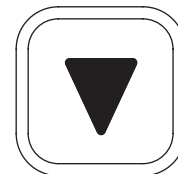

FG000021

Figure 12

Manual Scan: When pressing scan button once, for less than half-a-second, the frequency will be moved up in sequence to the next available signal.

Auto Scan: When pressing scan button for more than a half-a-second, the frequencies are automatically scanned to the next higher one and will continue until the button is again pressed to stop the scan.



Figure 13

FG000022

## 7. Ram Lock Switch

This switch is used to select the operational mode of the ram cylinder.

- O. In this position, the ram cylinder is "UNLOCKED" and allows for shock absorption and a more comfortable ride during travel.

**NOTE:** *The ram cylinder will automatically locked when the brake pedal is latch position or when the parking brake switch is engaged. However, the ram cylinder is automatically unlocked when the transmission lever position is forward or reverse.*

- I. In this position, the ram cylinder is "LOCKED" while in travel or park mode. Locking the ram cylinder cuts off the ram lock valve, securing and stabilizing the equipment from moving while digging.

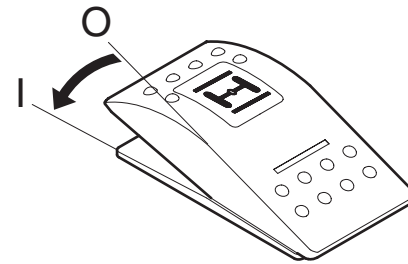

Figure 14

FG002176

## 8. Light Switch

This switch is used to turn on the lights.

- O. In this position, all lights are turned "OFF".
- I. In this position, all illumination lights of the instrument panel and the control switches are turned "ON".
- II. In this position, all illumination lights, work lights and headlights are turned "ON".

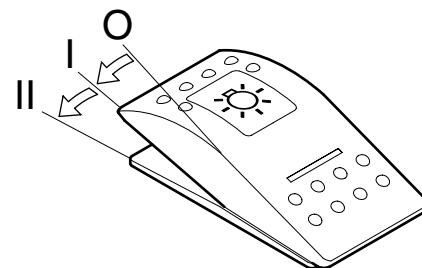

Figure 15

FG000024



---

**Do not leave instrument panel or work lights "ON" when the engine is not running. Leaving lights "ON" with the engine shut down will discharge batteries.**

---

## 9. Work Light Switch

Operates the work lights mounted on the boom.

- O. In this position, work light are turned "OFF".
- I. In this position, work light will turn "ON".



**Be certain that the work lights are turned "OFF" when traveling on the streets.**

---

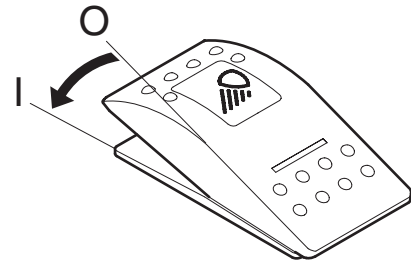

Figure 16

FG002177

## 10. Breaker / Boost / Shear Selector Switch

This switch is used to either select the breaker, power boost, or shear.

- O. In this position, a hydraulic pressure rise will be activated when pressing the button on the right-hand work lever (joystick).
- I. In this position, shear is activated.
- II. In this position, breaker is activated.



**Before using any attachment in a work application, be sure to check its functional control. Make sure that the desired movement or action is being activated by the control. e.g. opening/closing, CW/CCW, crowd/dump, etc.**

---

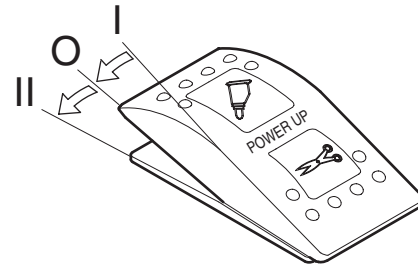

Figure 17

FG000025

## 11. Parking Brake Switch

This switch is used to park the equipment.

- O. In this position, parking brake is "RELEASED" and the monitor light on the front instrument panel turns "OFF."
- I. In this position, parking brake is "APPLIED" and the monitor light on the front instrument panel turns "ON."

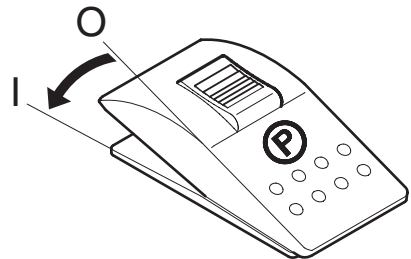

Figure 18

FG002178



## WARNING!

Set the parking brake switch in the "I"(APPLIED) position before leaving the excavator.

Make sure to "APPLY" the parking brake switch before trying to start the excavator.

---



## CAUTION!

Do not use the parking brake to stop the excavator, except in an emergency; otherwise, it might cause premature wear or damage of the brake.

---

### 12. Cabin Work Light Switch (Optional)

This switch is used to control the cabin work lights, if unit is equipped with them.

- O. In this position, all cabin work lights are turned "OFF."
- I. In this position, the front cabin work lights on the front top of cabin will turn "ON."
- II. In this position, the front cabin work lights on the front top of cabin and rear cabin work lights on rear top of cabin will turn "ON."

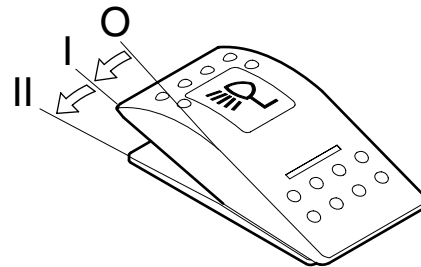

FG000026

Figure 19

### 13. Lower Wiper Switch (Optional)

This switch is used to control the lower front window wiper.

- O. In this position, lower windshield wiper is "OFF."
- I. In this position, lower windshield wiper runs at a constant speed.

**NOTE:** *Operating wiper without washer fluid or when there is sand or dirt present will damage the window and wiper.*

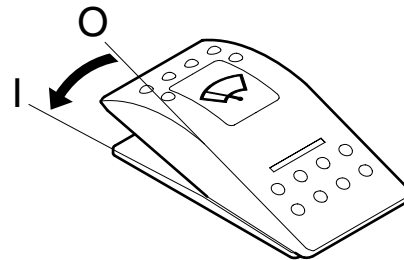

FG000028

Figure 20

## 14. Heater and Air Conditioner Control Panel

This panel is used to control air conditioner and heater in operator's compartment. Refer to "Heater and Air Conditioner Control Panel" on page 2-53 for more details.

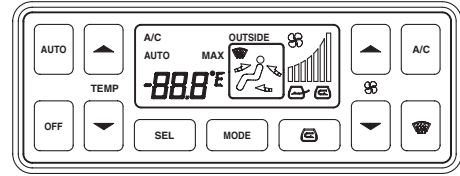

Figure 21

FG000029

## 15. Cigarette Lighter

Push the lighter all the way into the socket and release your hand. After pushing it in, it will be ejected when it is heated. If it does not eject after a short time, pull it out and have it serviced.

**NOTE:** *This cigarette lighter is for 24V only. Never connect a 12V electrical device to the lighter.*

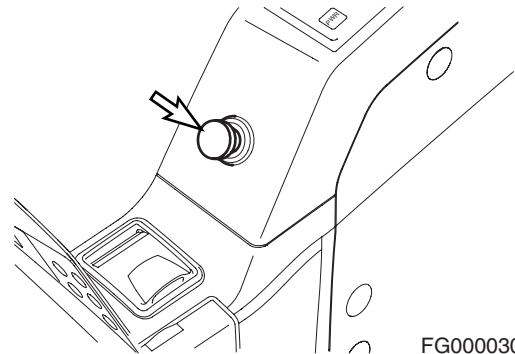

Figure 22

FG000030

## 16. Power Socket for 12 Volt

This is a power socket for only 12V DC devices.

This socket can be used for charging a cellular phone or powering a small 12V DC electrical device.

Open the cap when using it.

**NOTE:** *This socket is designed for small electrical capacity devices. Do not use this socket for large electrical capacity devices. Thus, damage can be avoided.*

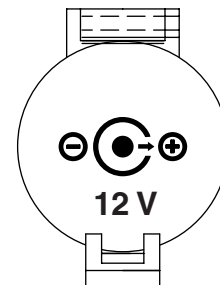

Figure 23

HAAE1990

## 17. Warning Light Switch (Optional)

If unit is equipped with a warning light, push this switch to activate it.

- O. In this position, the warning light is turned "OFF."
- I. In this position, the warning light turns "ON" and will start flashing.

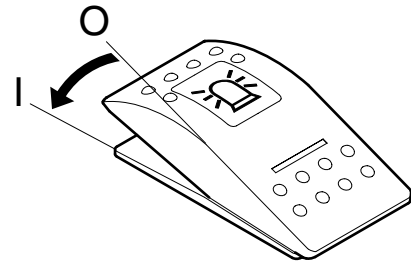

FG000027

Figure 24

## 18. Overload Warning Switch (Optional)

If unit is equipped with an overload warning device, push this switch to activate it.

- O. In this position, the overload warning device is turned "OFF."
- I. In this position, when a load is lifted that reaches the machine safe lifting limit, a warning light on the instrument panel will turn "ON" and a warning buzzer will sound.

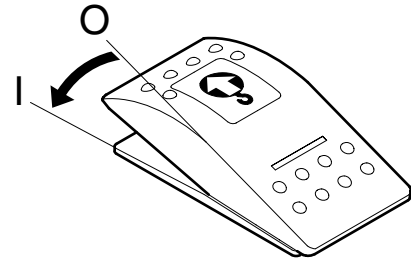

FG000032

Figure 25

---

### **WARNING!**

---

To prevent injury, do not exceed the rated load capacity of the machine. If the machine is not on level ground, load capacities will vary. There may be local government regulations about the use of excavators for lifting objects.

Please observe these regulations.

---

## 19. Fuel Heater Switch (Optional)

This switch is used to activate the fuel heater system. When the switch is activated, the fuel is warmed, depending upon the temperature of the fuel.

**NOTE:** *If the fuel temperature is above 5°C (41°F), heating system is not activated.*

- O. In this position, the fuel heater system is turned "OFF."
- I. In this position, the fuel heater system is turned "ON."

**NOTE:** *The starter switch must be "ON."*

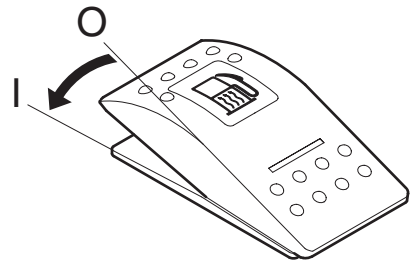

FG000033

Figure 26

## 20. Seat Warmer Switch (Optional)

If the seat is equipped with the optional seat warmer, push this switch to activate it.

When the seat is warmed, the warmer is automatically turned "OFF."

O. In this position, the seat warmer is turned "OFF."

I. In this position, the seat warmer is turned "ON."

**NOTE:** *The starter switch must be "ON" with the engine running, for the heater to operate.*

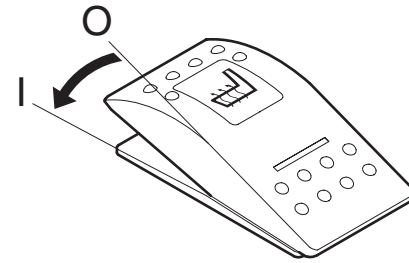

FG000034

Figure 25

## 21. Dozer / Outrigger Selector Switch (Independent Optional)

This switch is used to select the operational mode of front and rear work equipments. (If equipped)

Left two switches are for front equipment and right two switches are for rear equipment.

Each equipment is operated by individually or simultaneously as selected.

O. In this position, equipment is not selected.

I. In this position, equipment is selected.

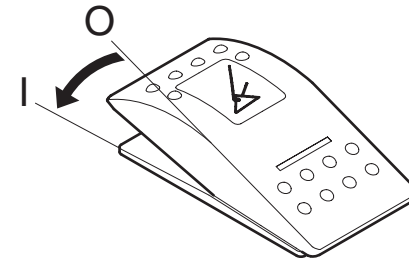

FG002179

Figure 26

## 22. Steering Console

See "Steering Console" on page 2-22.

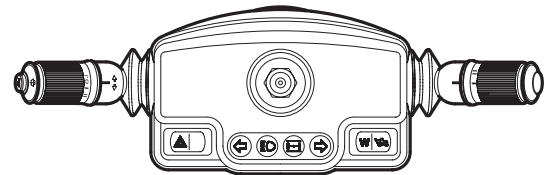

FG002180

Figure 27

## 23. Horn Button (Left-hand Work Lever)

Press the lower button on the top of the left-hand work lever (joystick) to sound horn.

**NOTE:** *The starter switch must be "ON."*

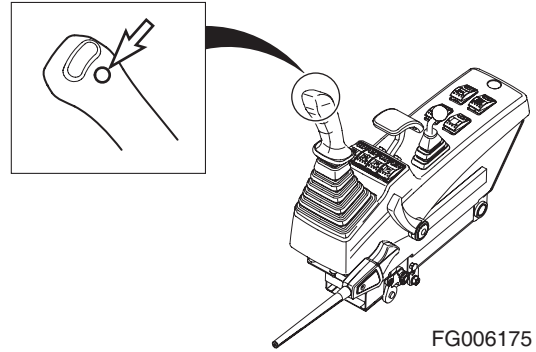

Figure 30

FG006175

## 24. Rotating Buttons

For a machine equipped with an attachment that rotates, press the upper two buttons on the top of the left-hand work lever (joystick) to rotate the attachment clockwise or counterclockwise. Left button is for counterclockwise and the right one is for clockwise.



### WARNING!

**Before using any attachment in a work application, be sure to check its functional control. Make sure that the desired movement or action is being activated by the control. e.g. opening/closing, CW/CCW, crowd/dump, etc.**

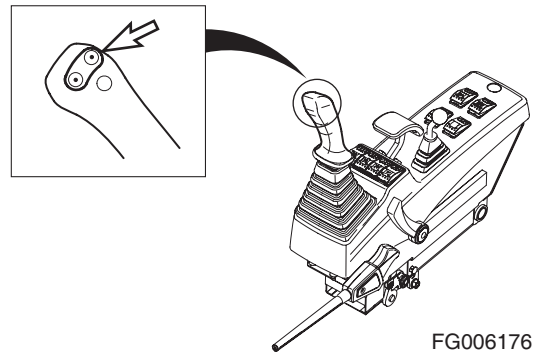

Figure 31

FG006176

## 25. Booster Button (Right-hand Work Lever)

Press the lower button on the top of the right-hand work lever (joystick) to boost the hydraulic pressure. Refer to the "Boost Mode" on page 3-26.

**NOTE:** *This button works with the breaker/boost/shear selector switch. See "10. Breaker / Boost / Shear Selector Switch" on page 2-14.*

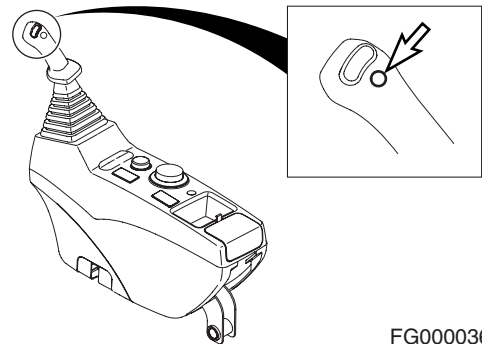

Figure 32

FG000036

## 26. Shear Buttons

For a machine equipped with shear, press the two upper buttons on the top of the right-hand work lever (joystick) to open or close the shear. Left button is for closing (crowd), right button is for opening (Dump).

**NOTE:** *These buttons work with the breaker/boost/shear selector switch. See “10. Breaker / Boost / Shear Selector Switch” on page 2-14.*



## WARNING!

Before using any attachment in a work application, be sure to check its functional control. Make sure that the desired movement or action is being activated by the control. e.g. opening/closing, CW/CCW, crowd/dump, etc.

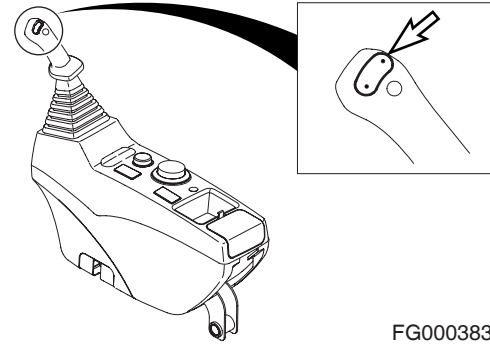

Figure 33

FG000383

## 27. Instrument Panel

See “Instrument Panel” on page 2-26.

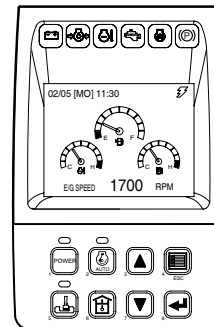

Figure 34

FG007154

## 28. Safety Lever

See “Safety Lever” on page 3-14.

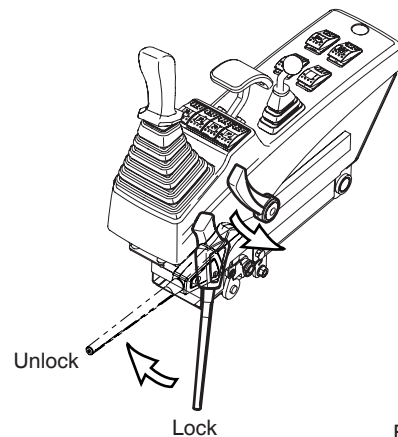

Figure 35

FG007022

## 29. Photo Sensor

The photo sensor detects the radiant energy of the sun.

In auto mode the air conditioner will automatically adjust the air temperature based on to the detected radiant energy.

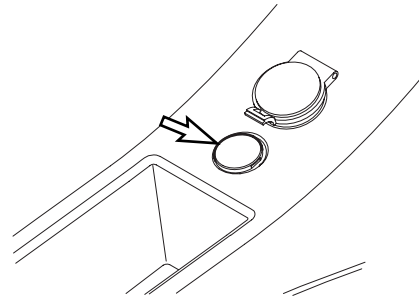

FG000399

**Figure 36**

# Steering Console

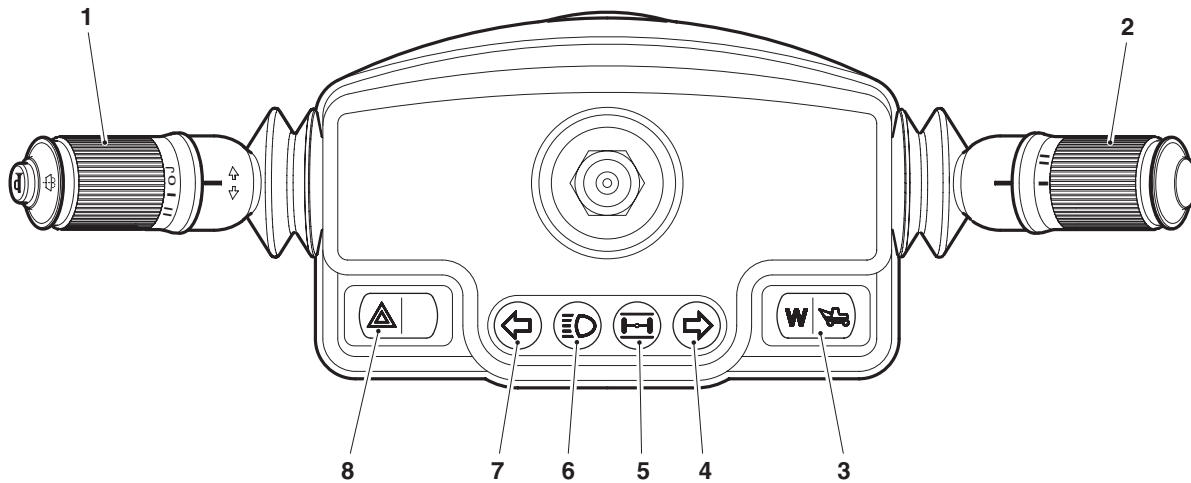

FG002181

Figure 37

Reference Number	Description
1	Combination Switch
2	Transmission Selector Switch
3	Work/travel Selector Switch
4	Right Turn Signal Light & Hazard Warning Light

Reference Number	Description
5	Ram Lock Indicator Light
6	High Beam Indicator Light
7	Left Turn Signal Light & Hazard Warning Light
8	Hazard Warning Light Switch

## 1. Combination Switch (LH)

### A. Windshield wiper switch

Activates the windshield wiper when the outside area of the lever is rotated.

ON : In this position, windshield wiper run at constant speed.

O : In this position, windshield wiper is "OFF"

JI : In this position, windshield wiper runs approximately on a three second intermittent cycle.

JII : In this position, windshield wiper runs approximately on a six second intermittent cycle.

### B. Windshield washer switch

When the outside area of the lever is pressed, it activates the washer pump and sprays fluid onto the windshield. (Only while being pressed.)

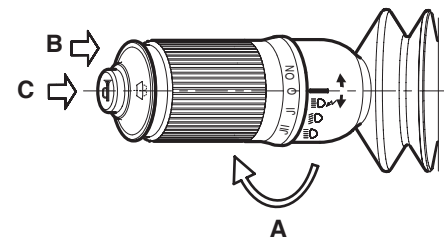

FG007018

Figure 38

**NOTE:** Do not operate windshield wiper without any washer fluid. If you operate it in spite of running out of fluid, the washer motor may be damaged. Check level in washer tank, and add fluid as required.

**NOTE:** If you use soapy water or synthetic detergent instead of window cleaning fluid, the wiper blade or painted surfaces may be damaged.

C. Horn switch

The center button of the lever activates the horn. (Only while being pressed.)

D. Turn signal lever

Operates the left and right direction lights.

- a. Right side direction switch - Pushing the lever forward, activates the right side direction lights and the direction indicator light on the instrument panel.
- b. Left side directional switch - Pushing the lever back, activates the left side directional lights and the directional indicator light on the instrument panel.

**NOTE:** When the turn is completed the lever automatically returns to the "NEUTRAL" position. Should it not, it can be manually returned by hand.

E. Dimmer switch

- a. Pull up - Momentarily turns "ON" both the low beams and high beams. (Returns to "NEUTRAL" position when released.)
- b. Neutral position - Normal low beams.
- c. Push down - Locks into position and lights up the high beams.

**NOTE:** High and low beams will only function with the light switch in the "II" position.

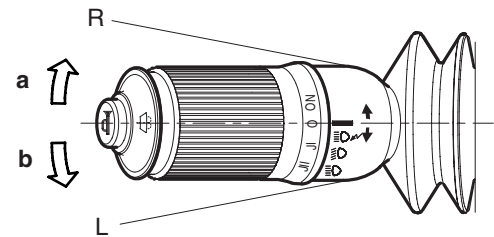

FG002183

Figure 39

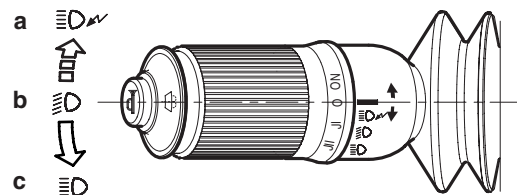

FG006179

Figure 40

2. Transmission Selector Switch (RH)

- a. Forward travel - Pushing the lever forwards the front selects the forward travel gear.
- b. Neutral - Central position puts the gear in the "NEUTRAL" position.
- c. Reverse travel - Pull the lever to the rear to select the reverse gear.
- d. Cruise control switch - When this switch is pressed while traveling, the travel speed is maintained without using the foot pedal. While in this mode the engine speed can be adjusted by turning the engine speed

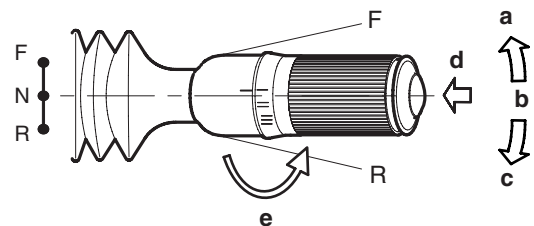

FG006180

Figure 41

control dial. If the brakes are applied or if the travel selector lever is moved to the "NEUTRAL" position the cruise control is turned "OFF."

When the auto idle mode is selected, the engine speed is lowered approximately 4 seconds after the cruise is turned "OFF."

The cruise control is not activated in the reverse travel mode.

- e. Travel speed selector switch - Selects one of three travel speeds in forward and reverse.

"I" Position - Creep speed.

"II" Position - Low speed.

"III" Position - High speed.

### 3. Work/travel Selector Switch

This switch is used to select work or travel modes.

- O. In this position, "Work Mode" is selected for normal operation.

- I. In this position, "Travel Mode" is selected for street travel.

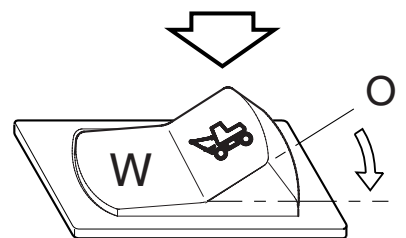

FG002190

Figure 42

## CAUTION!

When the switch is in the "I" position the work levers (joysticks) are not functional.

Although it is possible to travel with the switch in the work mode position, extreme caution should be exercised since the front attachment can be moved by accidentally touching the work levers (joysticks).

In the above condition the engine speed will not increase even though the foot pedal is pressed to the maximum position, this is not a malfunction.

### 4. Left Turn Signal Light & Hazard Warning Light

This light blinks when left turn signal is turned "ON."

Both lights blink when warning lights are turned "ON."

**NOTE:** *If left and right turn indicators blink together, or if they blink faster than normal, a light bulb is not operating or flasher solenoid is damaged.*

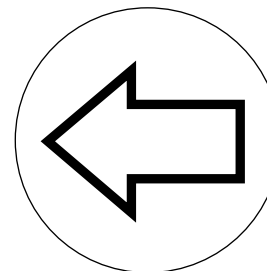

ACO0242L

Figure 43

## 5. Ram Lock Indicator Light

This light turns "ON" when the ram lock cylinder is "APPLIED".

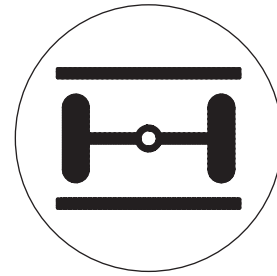

FG002187

Figure 44

## 6. High Beam Indicator Light

This light turns "ON" when the head lights are turned to "HIGH BEAM."

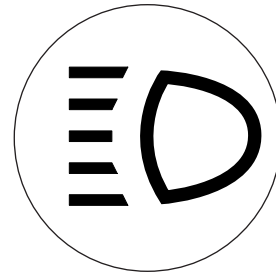

HA002023

Figure 45

## 7. Right Turn Signal Light & Hazard Warning Light

This light blinks when right turn signal is turned "ON."

Both lights blink when warning lights are turned "ON."

**NOTE:** *If left and right turn indicators blink together, or if they blink faster than normal, a light bulb is not operating or flasher solenoid is damaged.*

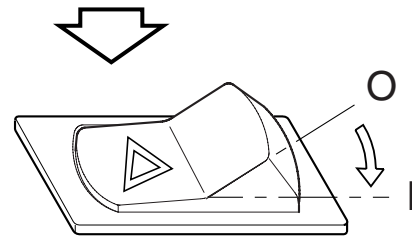

FG002191

Figure 46

## 8. Hazard Warning Light Switch

This light is used when the equipment is stopped due to a malfunction or when an emergency occurs. When this switch is pressed the directional indicator lights in front and back of the machine light up and flash, warning others in the area. At the same time the directional indicator lights on the instrument and hazard warning light switch will light up to warn the operator. The hazard warning lights operate independent of the starter switch.

- O. In this position, hazard warning lights are turned "OFF."
- I. In this position, hazard warning lights are turned "ON."

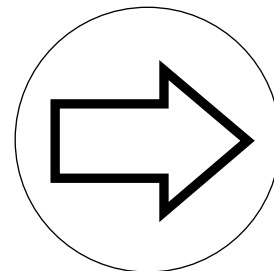

ACO0243L

Figure 47

# INSTRUMENT PANEL

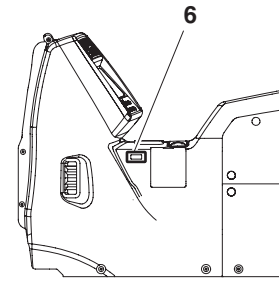
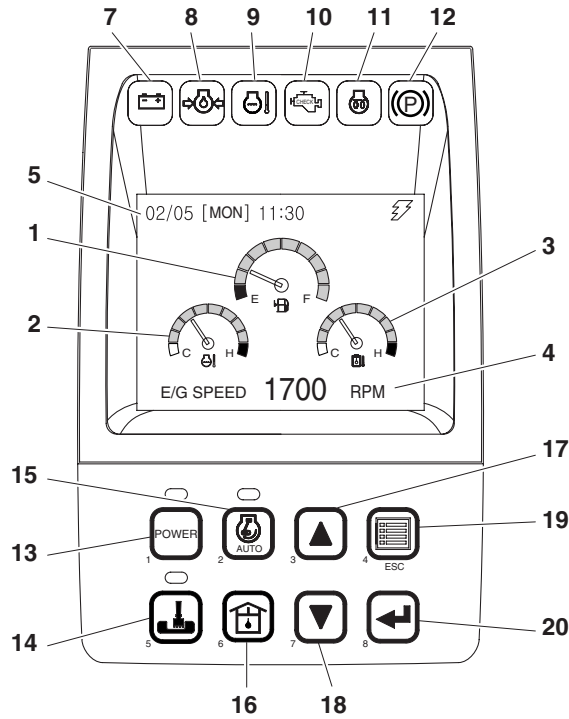

FG006164

Figure 48

Reference Number	Description
1	Fuel Gauge
2	Engine Coolant Temperature Gauge
3	Hydraulic Oil Temperature Gauge
4	Multifunction Gauge and Graphic Information Area (See page 2-32)
5	Digital Clock
6	Hour Meter
7	Charge Warning Light
8	Engine Oil Pressure Warning Light
9	Engine Coolant Temperature Warning Light
10	Engine Check Warning Light
11	Preheat Indicator Light

Reference Number	Description
12	Parking Brake Indicator Light
13	Power Mode Selector Button (See page 2-38)
14	Trenching Mode Selector Button (See page 2-38)
15	Auto Idle Selector Button (See page 2-39)
16	Flow Control Button (See page 2-39)
17	Up Arrow Button (See page 2-40)
18	Down Arrow Button (See page 2-41)
19	Display Selector Button (See page 2-41)
20	Selection Button (See page 2-41)

## Functional check

When the engine starter switch is turned to the "I" (ON) position, all gauge bands, switch/button indicator lights and indicator/warning lights will turn "ON" and the alarm buzzer will sound about two seconds.

During this functional check, a LOGO will appear on the multi function gauge in the graphic information area (3 and 4, Figure 48).

## Password Activated

If a password has already been set and the system has been "LOCKED," the password display will appear on the screen once the functional check has been completed. Enter the password into the text area and then engage the starter.

**NOTE:** Refer to "Set Password (Lock and Unlock)" on page 2-47, for further details.



---

If the password does not match the stored password, the engine will not start.

---

## 1. Fuel Gauge

Shows remaining fuel quantity in tank.

BLUE ZONE (■) - Indicates a normal fuel quantity.

RED ZONE (■) - Indicates that the fuel level is low.

If the gauge pointer moves into the red zone, the fuel level symbol will turn "ON," and be display in the screen. Stop operation and immediately and add fuel.

**NOTE:** See "Abnormal State Warning Symbols" on page 2-34, for location of this warning symbol and others.

Check the fuel level on firm, level ground.

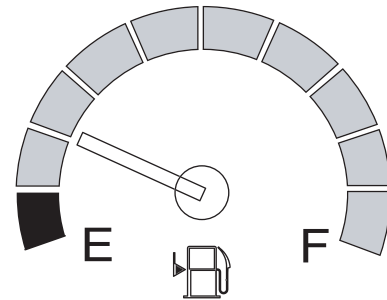

FG000040

Figure 49

## 2. Engine Coolant Temperature Gauge

The colored bands indicate the temperature of the engine coolant.

WHITE ZONE (□) - Indicates temperature is lower than the normal operating temperature.

BLUE ZONE (■) - Indicates temperature is within the normal operating range.

RED ZONE (■) - Indicates temperature is too high.

During operation, the pointer must be in the blue zone.

If the gauge pointer moves into the red zone, the engine coolant temperature warning light will turn "ON," a warning buzzer will sound, and the engine speed will be automatically reduced. Allow the engine to run at low idle speed until the temperature gauge registers in the blue zone again. When the blue zone is reached, allow the engine to idle for an additional three - five minutes before shutting down the engine. If not allowed to idle, heat surge may develop which will damage the engine. Allowing the engine to idle will dissipate heat. Check the coolant level, look for a loose fan belt, inspect for debris around radiator, and so on.

When the temperature reaches the normal range, the engine speed will automatically recover.

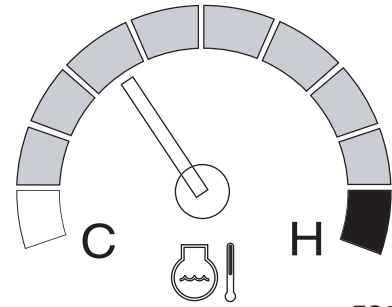

Figure 50

FG000041

## 3. Hydraulic Oil Temperature Gauge

The colored bands indicate the temperature of the hydraulic oil

WHITE ZONE (□) - Indicates temperature is lower than the normal operating temperature.

BLUE ZONE (■) - Indicates temperature is within the normal operating range.

RED ZONE (■) - Indicates temperature is too high.

During operation, the pointer must be in the blue zone.

If the gauge pointer moves into the red zone, the hydraulic oil temperature symbol will turn "ON," and be display in the screen. Allow the engine to run at low idle speed until the temperature gauge registers in the blue zone again.

**NOTE:** See "Abnormal State Warning Symbols" on page 2-34, for location of this warning symbol and others.

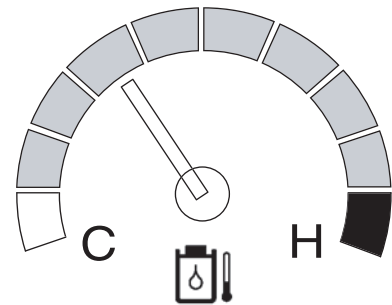
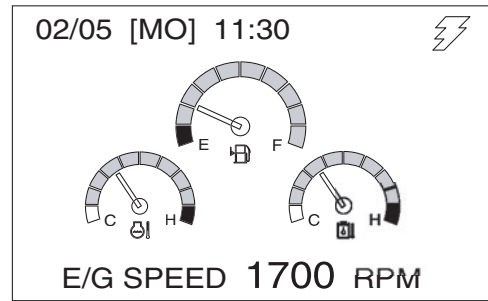

Figure 51

FG000042

## 4. Multifunction Gauge and Graphic Information Area

See “Multifunction Gauge and Graphic Information” on page 2-32. This section will have a more in-depth explanation of the display area.



FG000043

Figure 52

## 5. Digital Clock

A digital clock, shows the current time. The displayed contents are as follows.

Display	Description
MM	Month
DD	Date
W	Day
HH	Hour
mm	Minute
A (P)	AM (PM)

Refer to the “Setting Main Menu” on page 2-40 for time setting.

MM/DD [W] HH:mm

FG000044

Figure 53

## 6. Hour Meter

The hour meter is used to indicate the total number of running hours on the engine. The meter will flash every four seconds when the engine is running to indicate that it is functioning properly.

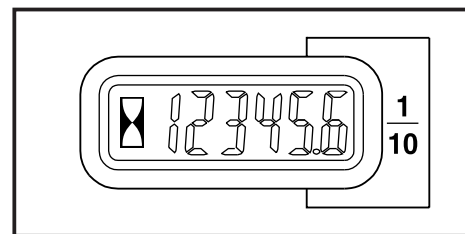

HAOA601L

Figure 54

## 7. Charge Warning Light

This indicator light will turn "ON" when the engine starter switch is turned "ON," and should go "OFF" after the engine starts. If it does not turn "OFF," shut the engine down immediately and determine the cause of the problem.

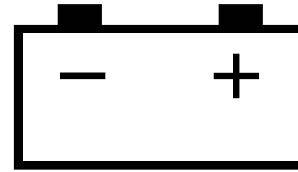

Figure 55

HAOA610L

## 8. Engine Oil Pressure Warning Light

This indicator light will turn "ON" when the engine starter switch is turned "ON," and should go "OFF" after the engine starts. For example, if the engine oil pressure becomes too low, the light will turn "ON" and a warning buzzer will sound. If this happens, shut the engine down immediately and determine the cause of the problem. If you continue to work when this light is "ON," it will result in serious engine damage.

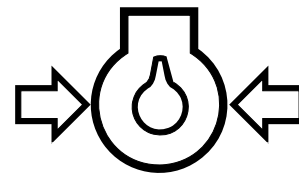

Figure 56

HAOA620L



---

If you continue to work when this light is "ON," it will result in serious engine damage.

---

## 9. Engine Coolant Temperature Warning Light

If engine coolant overheats, this light will turn "ON," an alarm will sound, and the engine speed will be automatically reduced, until coolant temperature drops. Do not turn engine "OFF" because this will cause coolant temperature to rise and may cause engine to seize due to heat surge.

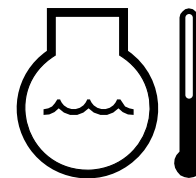

Figure 57

HAOD350L

**NOTE:** Check the engine coolant temperature gauge. If the gauge pointer moves into the red zone, the engine coolant temperature warning light will turn "ON," a warning buzzer will sound, and the engine speed will be automatically reduced. Allow the engine to run at low idle speed until the temperature gauge registers in the blue zone again. When the blue zone is reached, allow the engine to idle for an additional three - five minutes before shutting down the engine. If not allowed to idle, heat surge may develop which will damage the engine. Allowing the

engine to idle will dissipate heat. Check the coolant level, look for a loose fan belt, inspect for debris around radiator, and so on.

When the temperature reaches the normal range, the engine speed will automatically recover.

## 10. Engine Check Warning Light

This indicator light will turn "ON," when the engine needs to be checked.

**NOTE:** *If this light turns "ON" stop the machine and repair the cause of the fault.*

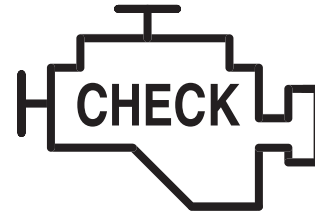

Figure 58

FG000045

## 11. Preheating Indicator Light

In cold weather this light indicates that the engine preheat function is operating.

When this indicator light turns "OFF," it means that the engine preheat cycle has been completed.

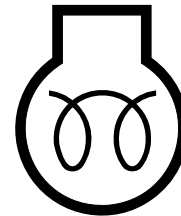

Figure 59

HAAE2000

## 12. Parking Brake Indicator Light

When parking brake is "APPLIED," this light turns "ON".

If vehicle is moved while parking brake applied, a warning alarm will sound.



---

If machine is moved while this light is "ON" it could cause premature wear or damage of the brakes.

Always "RELEASE" parking brake and make sure this light is "OFF" before moving machine.

---



Figure 60

BCS0790L

# MULTIFUNCTION GAUGE AND GRAPHIC INFORMATION

When the engine starter switch is turned to the "I" (ON) position, a LOGO will appear on the display screen for about two seconds.

When the LOGO disappears, the multifunction gauge and graphic information screen will appear.

The engine rpm is normally displayed at the bottom of the screen when the starter switch is first turned "ON." Each time the display selector button (19, Figure 48) is pressed, the digital readout changes in the following sequence; Engine speed (RPM) -> Battery voltage (VOLT) -> Front pump pressure (BAR) -> Rear pump pressure (BAR).

**NOTE:** See Figure 64 thru Figure 67.

A digital clock is located at the top of the display.

By using a combination of the mode selector buttons, information for filters and oils can also be displayed.

The display can also be set for the desired language.

Refer to the "Setting Main Menu" on page 2-40 for the language selection and information display sequences.

## Communication Indicator

Indicates the condition of communication between main controller and instrument panel.

1. Normal Condition:

The symbol will sequentially move like lightening.

**NOTE:** See Figure 64 thru Figure 67.

2. Abnormal Condition:

If the symbol is not displayed, it means there is a communication error.

**NOTE:** See Figure 63.

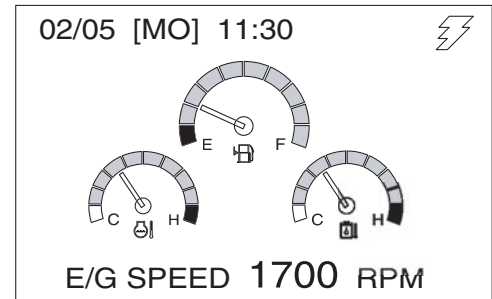

FG000043

Figure 61

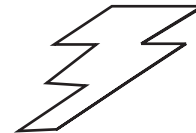

FG000047

Figure 62

## Communication Error Warning

If a communication error is generated between e-EPOS controller and instrument panel, this symbol will be displayed.

When this symbol is displayed, contact a *DOOSAN* distributor or sales agency.

**NOTE:** *If a communication error occurs during operation, the last mode setting is stored. e.g. power mode, work mode and auto idle are stored during failure.*

**NOTE:** *When starter switch is turned to the "I" (ON) position during a state of communication error failure, the e-EPOS controller will default to the following modes.*

*Power mode: Standard mode*

*Working mode: Digging mode*

*Auto idle: "ON" (Selection state)*

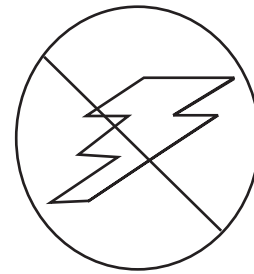

Figure 63

FG000048

## Engine Speed

The engine speed is numerically displayed.

**E/G SPEED 1700 RPM**

Figure 64

FG000049

## Battery Voltage

The battery voltage is numerically displayed. With the engine running, the reading should be between 26V - 30V.

When the starter is engaged or the preheat system is being used, the voltage can temporarily drop below 24V, but this is a normal condition.

**BATTERY 28.0 VOLT**

Figure 65

FG000050

## Front Hydraulic Pump Pressure

The front pump pressure is numerically displayed.

**NOTE:** *This pump is closest to engine flywheel housing or is the upper one of hydraulic pump.*

It displays the reading in BARs.

**FRONT PUMP 320 BAR**

FG000051

Figure 66

## Rear Hydraulic Pump Pressure

The rear pump pressure is numerically displayed.

**NOTE:** *This pump is the farthest from engine flywheel housing or is the lower one of hydraulic pump.*

It displays the reading in BARs.

**REAR PUMP 313 BAR**

FG000052

Figure 67

## Abnormal State Warning Symbols

1. Hydraulic Oil Overheating Warning
2. Pilot Filter Clogged Warning
3. Fuel Shortage Warning
4. Return Filter Clogged Warning
5. Air Cleaner Clogged Warning
6. Overload Warning (Optional)
7. Brake Oil Pressure Warning
8. Quick Clamp Released Warning

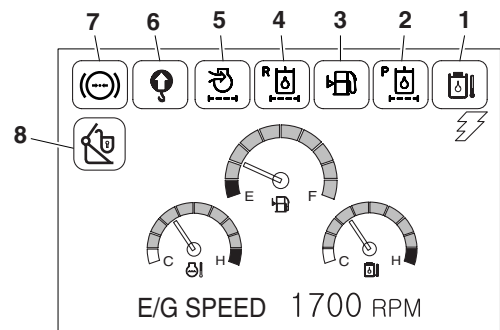

FG006166

Figure 68

## Examples of Warning Display

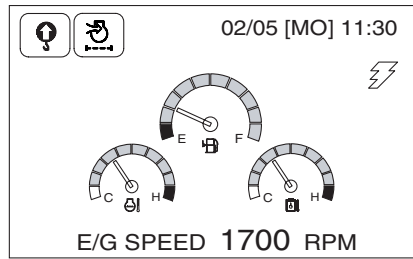

FG000059

<2 kinds of warning displayed>

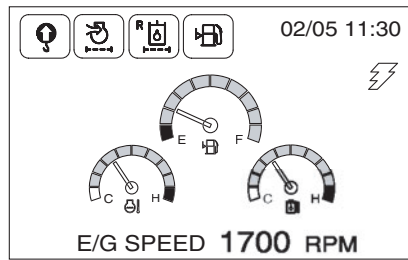

FG000060

<4 kinds of warning displayed>

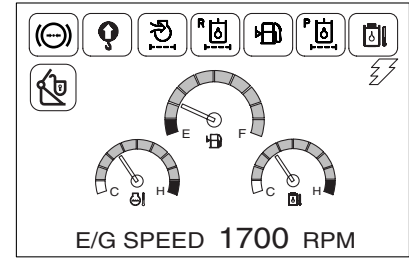

FG006167

<6 kinds of warning displayed>

**Figure 69**

### 1. Hydraulic Oil Overheat Warning

If the hydraulic oil temperature is too high, this symbol appears on the screen.

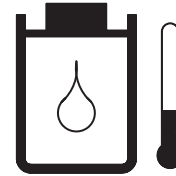

FG000056

**Figure 70**

### 2. Pilot Filter Clogged Warning

This symbol indicates when the pilot filter clogged.

If this symbol is displayed, immediately stop operation and replace the pilot filter.

After the pilot filter has been serviced, restart machine operation to remove the warning symbol.

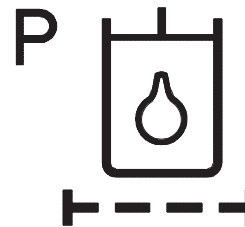

FG000055

**Figure 71**

### 3. Fuel Shortage Warning

If the fuel quantity is too low, this symbol appears on the screen.

If this light turns "ON," add fuel as soon as possible.

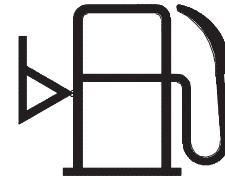

Figure 72

FG000057

### 4. Return Filter Clogged Warning

This symbol indicates when the hydraulic return filter is clogged.

If this symbol is displayed, immediately stop operation and replace the return filter.

After the return filter has been serviced, restart machine operation to remove the warning symbol.

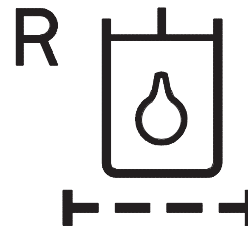

Figure 73

FG000054

### 5. Air Cleaner Clogged Warning

This symbol indicates when the air cleaner is clogged.

If this symbol is displayed, immediately stop operation and replace or clean the air filter.

After the air filter has been serviced, restart machine operation to remove the warning symbol.

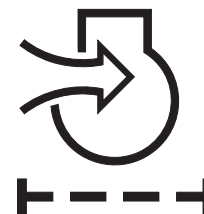

Figure 74

FG000053

## 6. Overload Warning (Optional)

If the overload warning switch is turned "ON," and this symbol appears on the screen and the warning buzzer sounds, that indicates that overloaded condition is occurring. Immediately reduce the load.



If this warning appears on the screen and a warning buzzer sound, reduce the load immediately.

If you continue to work, the machine can be turned over or damage to hydraulic components and structural parts could occur.

---

## 7. Brake Oil Pressure Warning

This symbol indicates when the hydraulic pressure drops brake oil circuit when the symbol indicates and alarm also sounds.



Never operate or travel machine when this light is turned "ON" or when alarm is sounding.

Always investigate cause of the drop in brake oil pressure, and repair problem before operating or traveling machine.

---

## 8. Quick Clamp Released Warning

If the quick clamp switch is "UNLOCKED", and this symbol appears on the screen and the warning buzzer sound.



When the attachment is still connected to the machine, while the switch is "I" (🔓) position, do not operate the machine or the attachment might fall to the ground. It would cause personnel injuries.

---

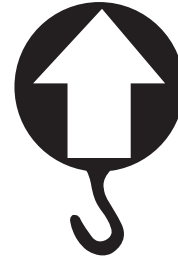

Figure 75

FG000253

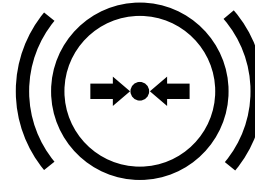

Figure 76

BCS0800L



Figure 77

FG002195

# MODE SELECTOR BUTTONS

1. Power Mode Selector Button
2. Trenching Mode Selector Button
3. Auto Idle Selector Button
4. Flow Control Button

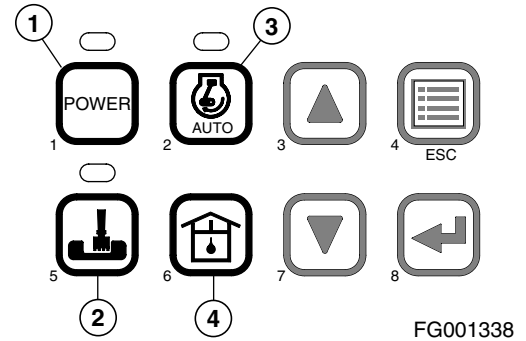

Figure 78

## 1. Power Mode Selector Button

This power mode is suitable for heavy-duty work that requires a high operating speed. Push this button to turn power mode "ON" or "OFF."

When the power mode button is pushed to the "ON" position, an indicator light above it turns "ON."

When the power mode button is pushed again, it is turned "OFF" and the power mode is deactivated and returns to the standard operating mode.

When turning the engine starter switch to the "I" (ON) position, the power mode is automatically defaulted to "Standard Mode."

**NOTE:** For further details, see "Mode Selection" on page 3-25.



Figure 79

FG000063

## 2. Trenching Mode Selector Button

This work mode is suitable for smooth trench or smooth trench wall. Push this button to turn trenching mode "ON" or "OFF."

When the trenching mode button is pushed to the "ON" position, an indicator light above it turns "ON."

When the trenching mode button is pushed again, it is turned "OFF" and the trenching mode is deactivated and returns to the digging mode.

When you turn the engine starter switch to the "I" (ON) position, the work mode is automatically defaulted to "Digging Mode."

**NOTE:** For further details, see "Mode Selection" on page 3-25.

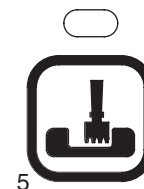

Figure 80

FG000064

### 3. Auto Idle Selector Button

When the auto idle system is activated, the engine will automatically reduce speed to "IDLE" approximately four seconds after all of the control levers are in the neutral position. This system is designed to reduce fuel consumption and noise.

When the auto idle selector button is pushed to the "ON" position, an indicator light above it turns "ON."

When the auto idle selector button is pushed again, it is turned "OFF" and the engine speed will return to the setting of the engine speed dial and will remain at this speed despite control lever position, until the engine speed dial is moved.



Figure 81

FG000065

### 4. Flow Control Button

When the button is pushed, you can control the hydraulic oil flow rate.

The flow control button is used to set the flow rate of pump to match the installed tool/attachment for optimal performance, without damaging it.

**NOTE:** For further details, see "Flow Control" on page 2-49.

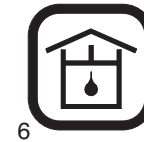
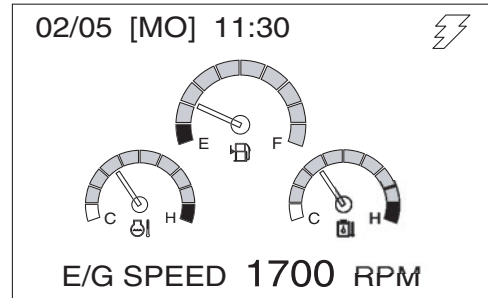

Figure 82

FG000066

# SETTING MAIN MENU

By using a combination of the selector buttons (Figure 84), you can review and set the contents of the display screen. Items such as language, time and filter/oil information can be checked, and if necessary, set with new information.



FG000043

Figure 83

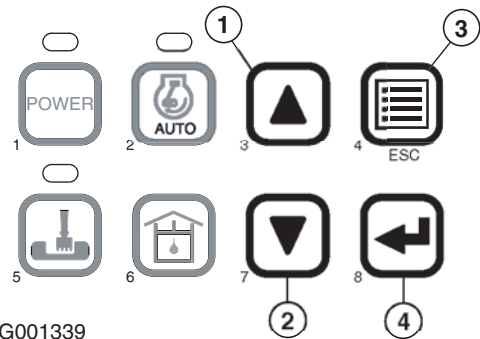

FG001339

Figure 84

## 1. Up Arrow Button

Up arrow button (▲), is used to move a menu item "Up" or to the "Left."



FG000068

Figure 85

## 2. Down Arrow Button

Down arrow button (▼), is used to move a menu item "Down" or to the "Right."



Figure 86

FG000069

## 3. Display Selector Button (ESC - Escape)

Display selector button (☰), is used to change the displayed information on the screen. Each time the display selector button is pressed, the digital readout changes.

**NOTE:** *When setting the main menu, this button is used as the menu / exit button (ESC). To access the menus the button must be pressed and held for three seconds.*

**NOTE:** *When this button is used for menu / exit button, it is used to access to main menu or return to a previous screen from each submenu.*



Figure 87

FG000070

## 4. Selection Button

Selection button (↩), is used to set a menu or clear the operating hour of filter/oil.



Figure 88

FG000071

# Display Selection and Escaping

## Display Selection

When the display button (Figure 89) is pressed for more than three seconds, the main menu screen (Figure 91) is displayed.

In the normal display screen, the engine speed (rpm), battery voltage (volt), front pump pressure (bar), and rear pump pressure (bar) can be displayed.



FG000070

Figure 89

## ESC Button

The screen will return from the main menu to the normal display screen, by again pressing the "ESC" (  ) button.

**NOTE:** *If more than twenty seconds are spent in any menu, without changing the screen, it will return to the normal display screen.*

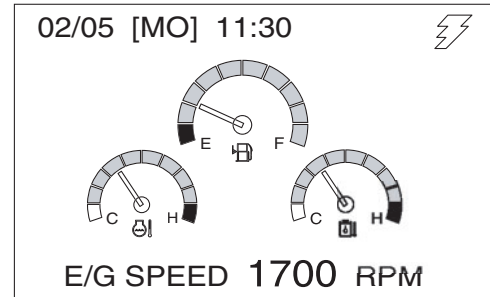

FG000043

Figure 90

## Main Menu

The menu selection can be changed by pressing the "UP" (▲) or "DOWN" (▼) buttons. The selected menu item will be highlighted, and a cursor will appear by the menu item.

When the selected menu item is highlighted, press the "SELECT" (◀) button to enter the next submenu.

1. "Language" on page 2-43.
2. "Set Clock" on page 2-43.
3. "Filter / Oil Info" on page 2-44.
4. "Adjust Display" on page 2-46
5. "Set Password (Lock and Unlock)" on page 2-47

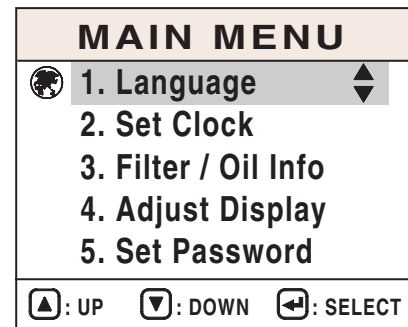

FG000072

Figure 91

## Language

When the cursor is on "Language," press the "SELECT" (◀) button. The language submenu will appear.

The desired language can be selected by using the "UP" (▲) or "DOWN" (▼) buttons.

The display can be set for the desired language.

Press the "SELECT" (◀) button to set the selected language.

**NOTE:** *If more than twenty seconds are spent in the menu, without changing the screen, it will return to the normal display screen.*

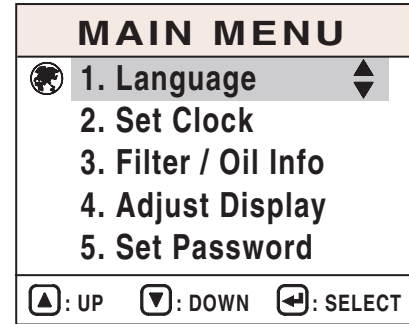

FG000072

Figure 92

## Set Clock

When the cursor is on "Set Clock," press the "SELECT" (◀) button. The set clock submenu will appear.

**NOTE:** *If more than twenty seconds are spent in the menu, without changing the screen, it will return to the normal display screen.*

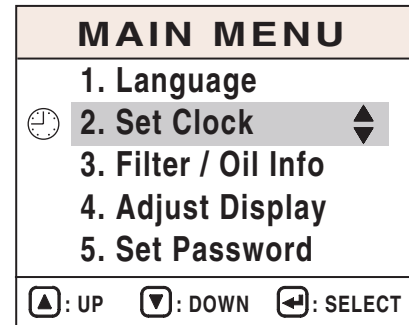

FG000075

Figure 93

## Setting Method

1. Move the cursor to desired number by using the "SELECT" (◀) button. When selected the number will flash.
2. Set the time by using the "UP" (▲) or "DOWN" (▼) buttons.
  - "+" (▲), "-" (▼): Increase or decrease number.
  - "MOVE" (◀): Confirm and move the cursor to next number.
  - "ESC" (☰): Exit to the main menu.

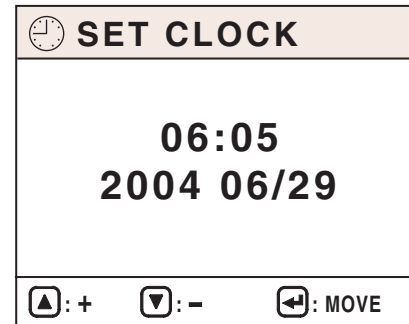

FG000076

Figure 94

### '00' Minute Setting

1. Simultaneously press the "SELECT" (◀) button and "UP" (▲) button.
2. If the displayed time is 30 minutes or less, the clock will display the preceding hour.
3. If the displayed time is more than 30 minutes, the clock will display the succeeding hour.
4. When the preceding hour is more than 23, the day will be increased.

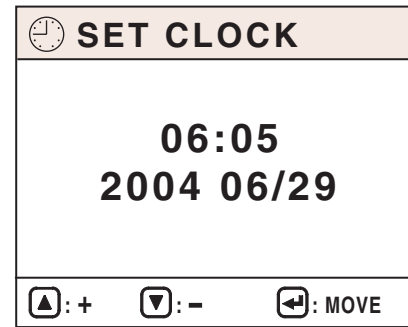

FG000076

Figure 95

### Filter / Oil Info

When the cursor is on "Filter/Oil Info," press the "SELECT" (◀) button. The filter/oil information submenu will appear.

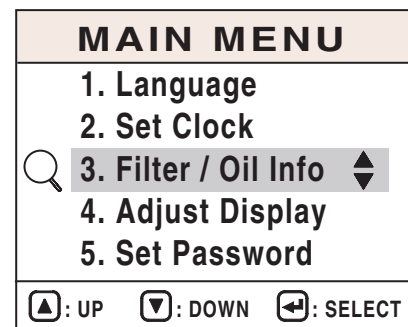

FG000077

Figure 96

Each symbol can be selected by pressing the "UP" (▲) or "DOWN" (▼) buttons. At the bottom of the screen the operating hour (Hrs) of each filter and/or oil is displayed.

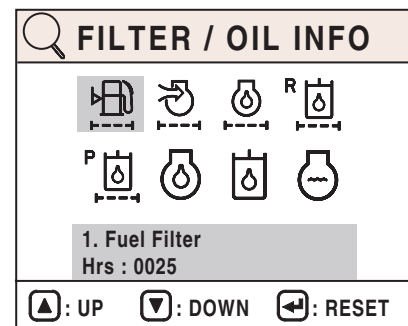

FG000078

Figure 97

## Menu Display Order and Icon Explanation

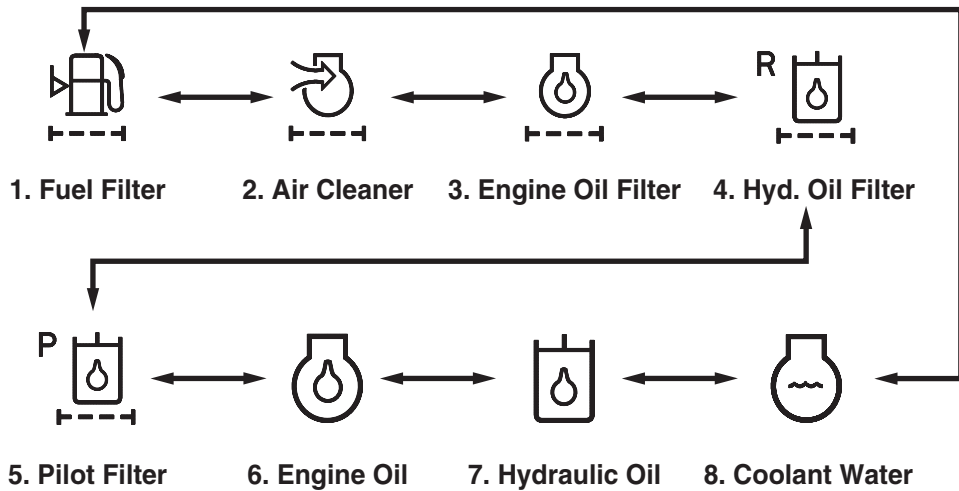

FG001358

Figure 98

### Filter / Oils Operating Hour Reset

After changing a filter or oil, reset the operating hour to zero (Hrs: 0000). The next replacement period can then be easily checked. The operating hours are only accumulated while the engine is running.

On the filter / oil information screen, press the "SELECT" (←) button and then the reset screen will be displayed.

On the reset screen, the operating hour can be changed to zero hour (Hrs: 0000) by pressing the "SELECT" (←).

If the "SELECT" (←) button is pressed, the reset will be completed. and the screen will be returned to the previous menu.

If the "ESC" (⏏) button is pressed, the screen will be returned to the previous menu without being reset.

**NOTE:** *If more than twenty seconds are spent in the menu, without changing the screen, it will return to the normal display screen.*

The screen is returned to the main menu by pressing the "ESC" (⏏) button.

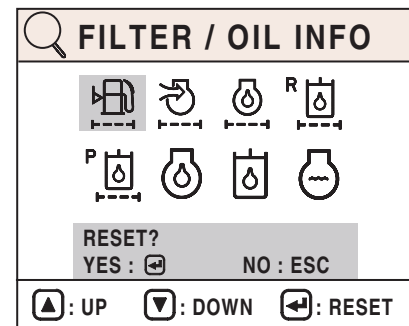

HAAE1960

Figure 99

## Adjust Display

When the cursor is on "Adjust Display," press the "SELECT" (↵) button. The adjust display submenu will appear.

The desired brightness adjustment can be selected by using "UP" (▲) or "DOWN" (▼) buttons.

**NOTE:** *When the equipment shipped, the default brightness is set to 50%.*

The screen is returned to the main menu by pressing the "ESC" (⏏) button. The display is then saved.

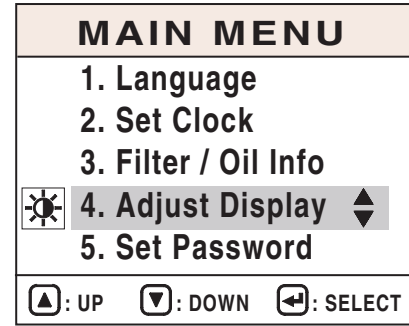

FG000080

Figure 100

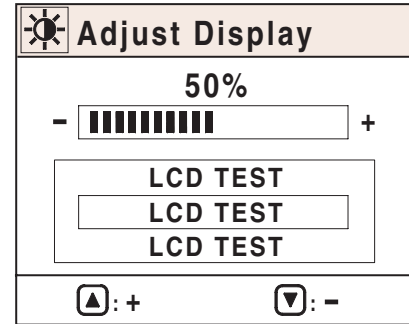

FG000081

Figure 101

## Set Password (Lock and Unlock)

Use extreme care when setting the password for starting the engine. If a mistake is made when entering the number, and the number is excepted by the system, as being correct, that number will be the only one that will allow the security system to be activated or deactivated.

Write your password down and keep it in a safe location.

Password numbers can only use numbers between 1 and 8. The small number to the lower left of each button on the instrument panel, indicates the number that will be entered when that button is pressed. Numbers "0" and "9" are invalid choices.

Example:

2785 is acceptable.

9024 is not acceptable.

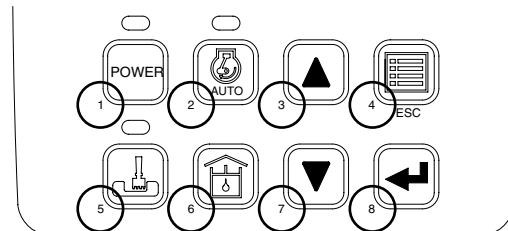

HAAE2010

Figure 102

When the cursor is on "Set Password" press the "SELECT" (←) button. The set password submenu will appear.

**NOTE:** The screen can be returned to the main menu by pressing the "ESC" (ESC) button (3, Figure 84).

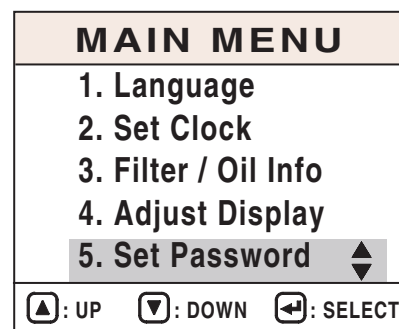

FG000227

Figure 103

Password inquiry menu will be displayed.

**NOTE:** The initial password is "1111."

The password can be changed within ten minutes while the starter switch is in "I" (ON) position.

After changing password, be sure to use the changed password.



**Failure to enter correct password three times, will return normal display screen, and another attempt will not be possible for ten minutes.**

A three item menu will be displayed. The items are "LOCK," "UNLOCK," and "CHANGE PASSWORD." An item can be selected by using the "UP" (▲) or "DOWN" (▼) buttons, and then selected by pressing the "SELECT" (←) button.

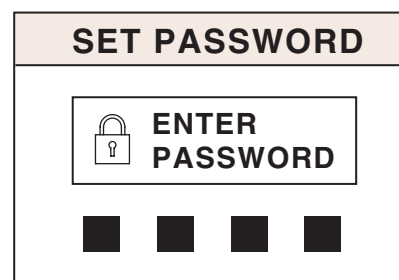

FG000228

Figure 104

Press "ESC" (  ) button (3,Figure 84) for 1 more second, it returns to main menu.

According to the selection of adoption (lock) or nonadoption (unlock), the password function will be in working or nonworking.

When you want to change a password, follow below procedure.

1. Move the cursor to "Change Password."
2. Input desired 4 digits password using selector buttons (at the first column). Input the same password one more time (at the second column)
3. Select adoption (lock) or nonadoption (unlock) at set password menu.

**NOTE:** *Keep in mind never to forget password.*

**NOTE:** *Please contact a DOOSAN distributor, if you forget your password.*

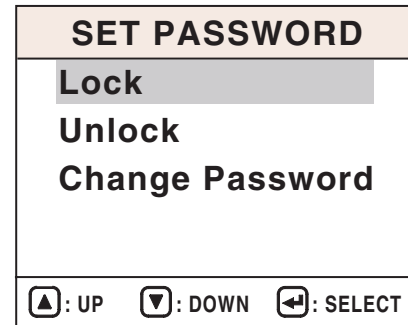

FG000229

Figure 105

# FLOW CONTROL

The flow control is used to set the proper flow rate for an optional attachment (if equipped). The flow control screen is accessed directly from the normal display screen without going through the main menu or any submenus.

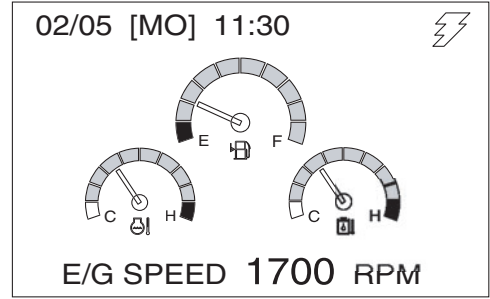

FG000043

Figure 106

When the flow control button (Figure 82 and Figure 107) is pressed at the normal display screen (Figure 106), the flow control screen (Figure 109) will be displayed.



FG000066

Figure 107

Select a tool by using the breaker / boost / shear selector switch. The symbol in the upper left corner of the display screen will change according to the position that the selector switch is in. Compare the symbols shown in (Figure 109 and Figure 110).

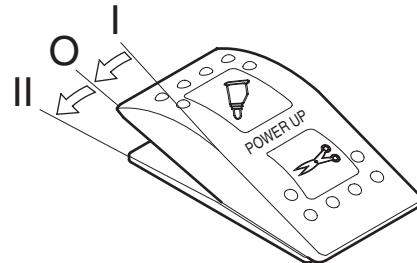

FG000025

Figure 108

## Adjusting Flow Rate

Use "UP" (▲) or "DOWN" (▼) buttons to adjust flow rate.

"UP" (▲) button is used to increase a flow rate.

"DOWN" (▼) button is used to decrease a flow rate.

Flow Control Step	Pump Flow Setting (l/min)
1	38
2	61
3	80
4	91
5	101
6	133
7	142
8	149
9	165
10	168

Pump flow setting is at rated engine speed, for only the output of one pump.

Pump displacement will vary according to changes in engine rpm.

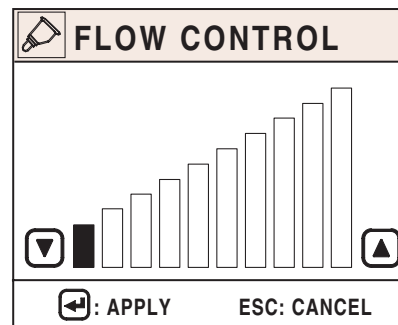

FG000254

Figure 109 Breaker

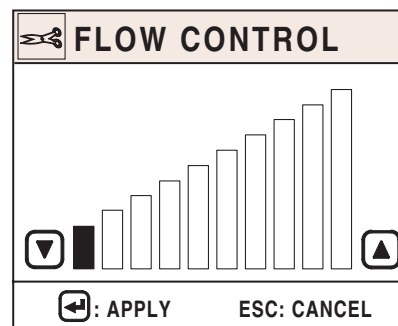

FG000255

Figure 110 Shear

## Escape

- Press flow control button (🏠, Figure 107) to return to normal display screen and save the flow rate setting.
- If there is no adjustment for twenty seconds, the flow control screen will return to the normal display screen.

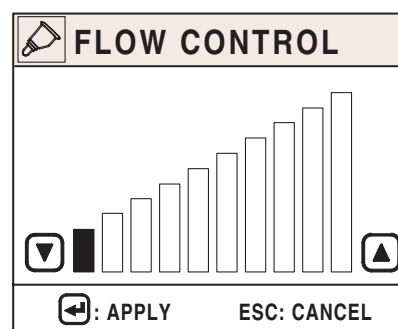

FG000254

Figure 111

# OPERATION SELECTION DISPLAY

In the monitor you can see the application that is currently selected.

## Power Boost Selection

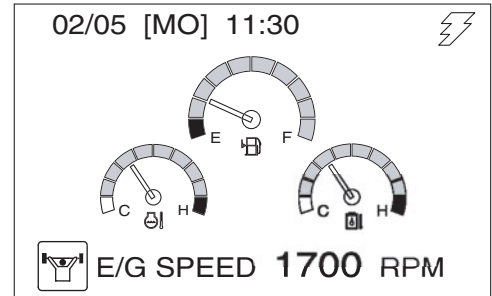

FG000257

Figure 112

## Breaker Selection

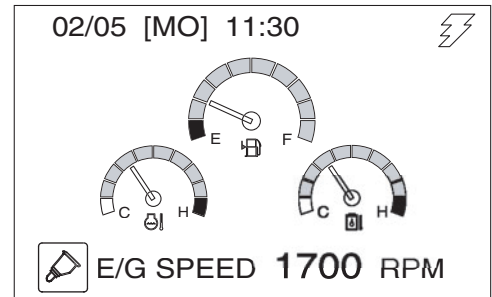

FG000258

Figure 113

## Shear Selection

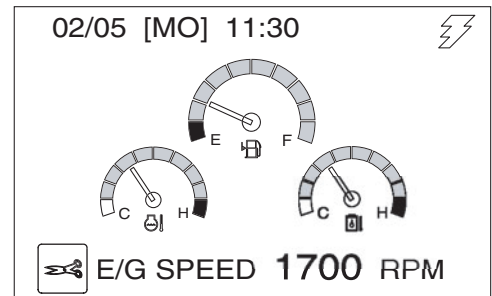

FG000259

Figure 114

## Overload Alarm Selection (Optional)

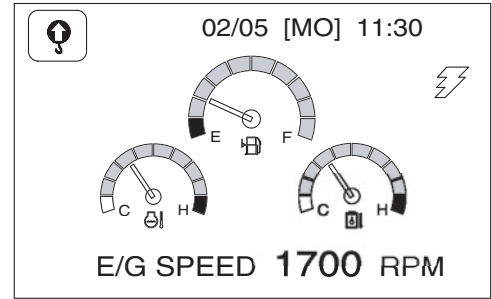

FG000260

Figure 115

## Quick Clamp Operation Selection (Optional)

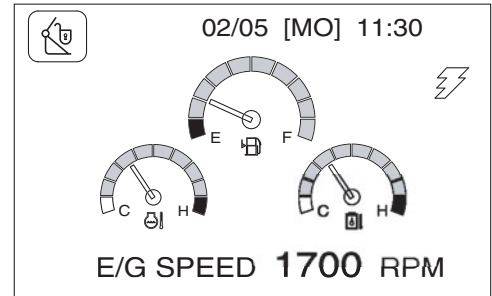

FG000388

Figure 116

# HEATER AND AIR CONDITIONER CONTROL PANEL

## Location of Controls and Vents

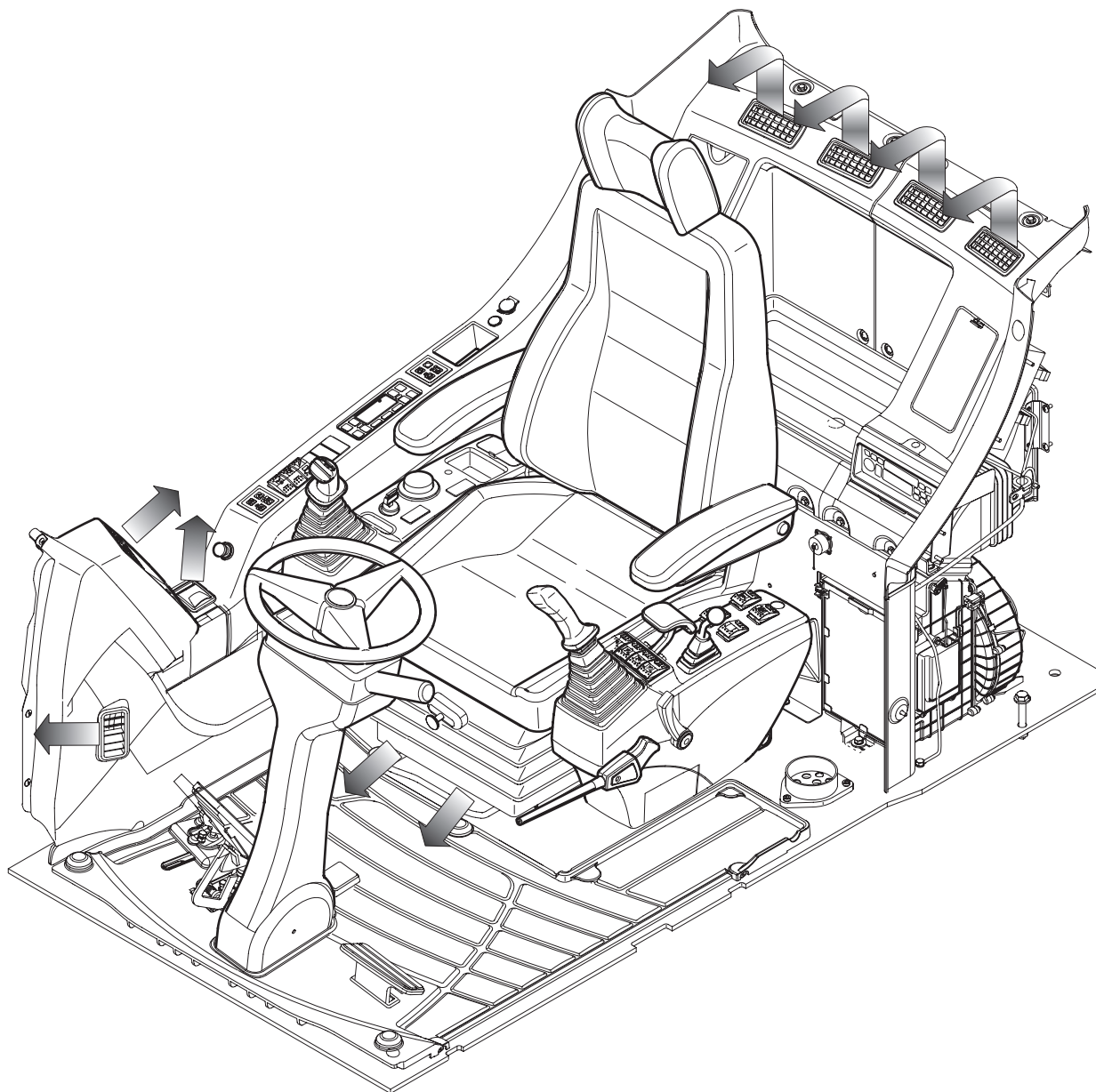

FG007166

**Figure 117**

The heater and air conditioner are combined into one unit in the rear cover behind the operator's seat.

The operator can control cabin temperature using the control panel installed in the switch panel.

# Control Panel

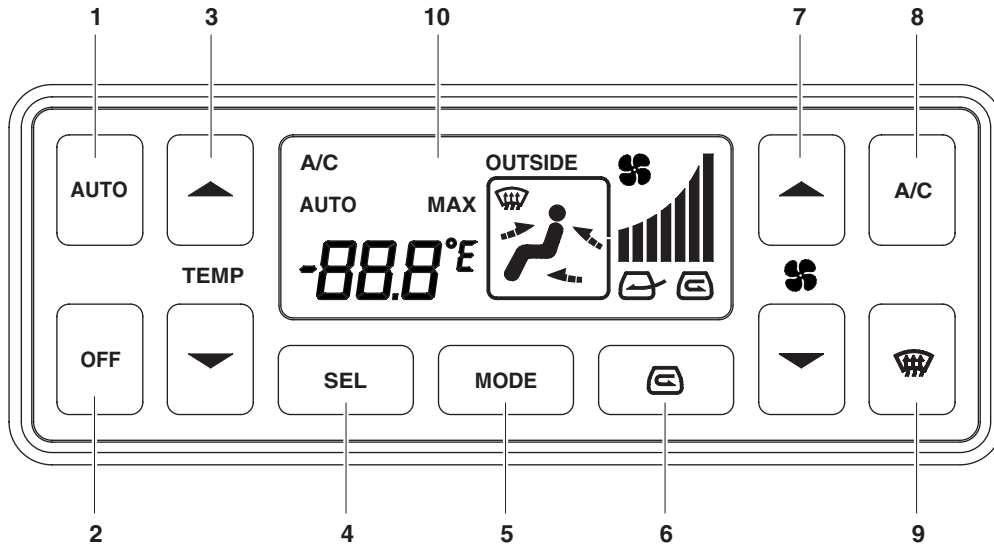

FG000086

Figure 118

Reference Number	Description
1	Automatic Temperature Control Button
2	Off Button
3	Temperature Control Button
4	Temperature Unit Selector Button
5	Air Outlet Selector Button

Reference Number	Description
6	Air Inlet Selector Button
7	Fan Speed Selector Button
8	Air Conditioner Button
9	Defroster Button
10	LCD Display

**NOTE:** When the light switch is turned to "I" or "II" position, the LED for illuminating in the control panel will turn "ON."

## 1. Automatic Temperature Control Button

This button is used to control the temperature level in the cabin, according to the temperature setting of the operating panel.

When the automatic temperature control function is activated, the word "AUTO" will be displayed in the upper left of LCD display.

When the system is in "AUTO" mode, specifications can be manually changed by pushing another button.

If a function is manually changed, the word "AUTO" does not appear in the LCD display, but the unchanged functions will remain in "AUTO" mode.

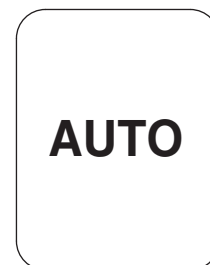

FG000088

Figure 119

## 2. Off Button

This button is used to stop the fan and air conditioner.

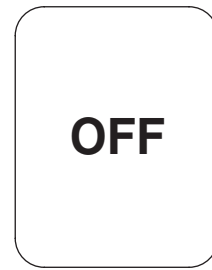

Figure 120

FG000089

## 3. Temperature Control Button

These buttons are used to control the cabin temperature.

Temperature is adjustable from 17°C (62°F) to 32°C (90°F) by 0.5°C (1°F) increments.

Temperature setting is displayed on the LCD.

When the system is turned "ON," the previously set temperature is used as a starting point.

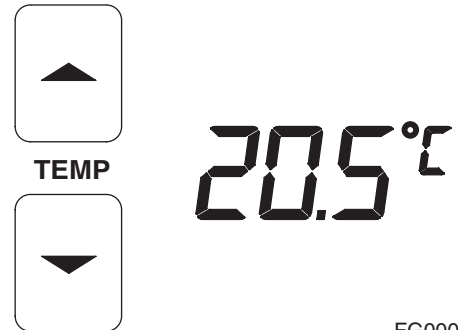

Figure 121

FG000090

## 4. Temperature Unit Selector Button

This button gives the choice to select either °C or °F.



Figure 122

FG000094

## 5. Mode Selector Button

This button is used to select which combination air outlets will be used.



Figure 123

FG000096

- A. Used to direct air flow to upper portion of operator's cabin from both the front and rear.

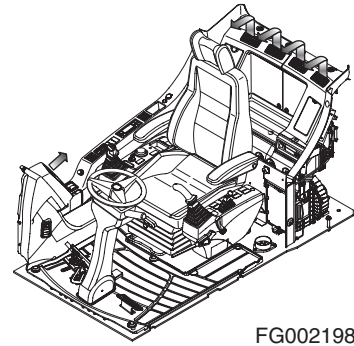

FG002198

**Figure 124**

- B. Used to direct air flow to upper portion of operator's cabin from both the front and rear. It will also deliver air to the lower portion of operator's cabin from under the operator's seat.

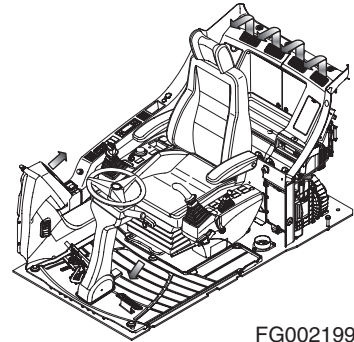

FG002199

**Figure 125**

- C. Used to direct air flow to lower portion of operator's cabin and feet.

This mode is mainly used for heating.

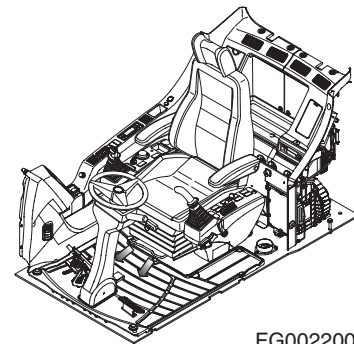

FG002200

**Figure 126**

- D. Used to direct air flow to the front window and to operator's feet.

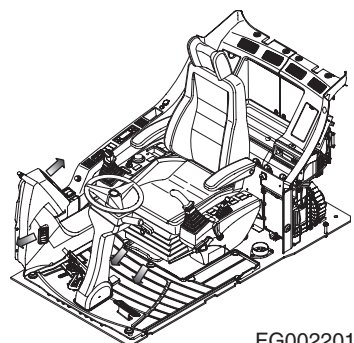

FG002201

**Figure 127**

## 6. Air Inlet Selector Button

This button is used to select fresh air from outside the cabin, or recirculate air within the cabin.

Pressing this switch enables the choice between fresh air and recirculating air within the operator's compartment. The select mode is displayed on the LCD.



FG000101

Figure 128

- A. "A" Symbol - Draws fresh air into operator's compartment. Used to exchange air within the operator's compartment with fresh air. Used to remove condensation or ice on window (Winter / Rainy Season).
- B. "B" Symbol - Recirculates air within the operator's compartment. Used to quickly warm or cool the operator's cabin.

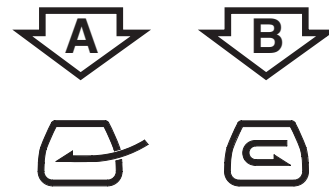

FG000102

Figure 129

## 7. Fan Speed Selector Buttons

These buttons are used to control the speed of the blower fan.

Momentarily, pressing a button, changes the speed one stage.

Continuously pressing and holding a button, repeatedly changes the speed.



FG000103

Figure 130

## 8. Air Conditioner Button

This button is used to turn the air conditioner "ON" or "OFF."

When this function is activated, an "A/C" is displayed in the upper left corner of the LCD.



FG000105

Figure 131

## 9. Defroster Button

Used to direct air flow to front window.



FG000106

Figure 132

## 10. LCD Display

This display shows the current setting.

### Memory Function

The air conditioner panel has a memory function. When the starter switch is turned "OFF" the settings for the panel, will be stored. When the excavator is started, the last stored setting will be used.

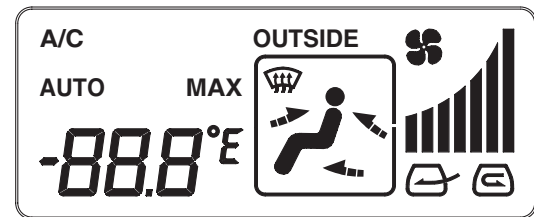

FG000107

Figure 133

## Additional Operating Instructions

A proper indoor temperature in summer is 5 - 6°C (10 - 12°F) less than the outdoor temperature.

Operate the air conditioner for twenty - thirty minutes a week to circulate the refrigerant in the system.

**NOTE:** *The blower button should be on "Three Bars."*

If operating the air conditioner or heater for a long time, operate the air inlet selector button, and when smoking, vent the air to the outside to prevent irritation to eyes.

# STEREO

Before operating the stereo or CD player, read operation manual enclosed with stereo.

## Stereo

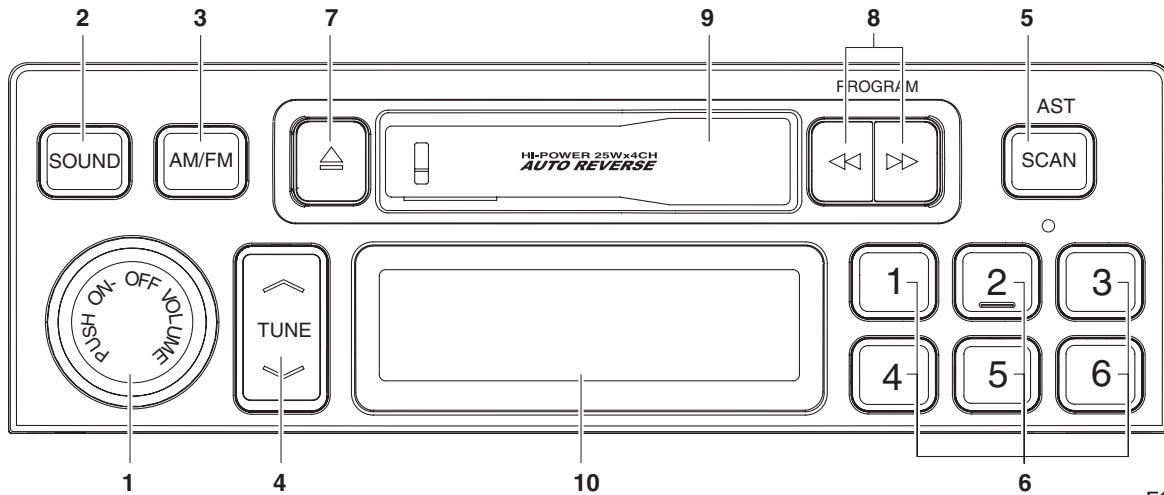

FG000108

Figure 134

Reference Number	Description
1	Power / Volume Control
2	Sound Mode Selector
3	Band Selection
4	Tuning Up / Down
5	Scan Function / Auto Store

Reference Number	Description
6	Preset Station
7	Tape Ejection
8	Fast Forward / Rewind
9	Tape Loading Slot
10	LCD

# CD Player (Optional)

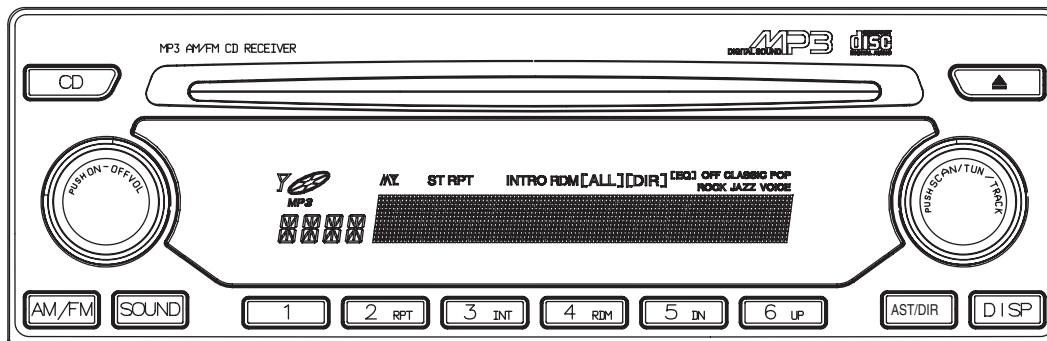

FG000109

Figure 135

# MISCELLANEOUS ELECTRICAL DEVICES

## Cabin Light

A light is installed on the top of the operator's compartment.

The light will work despite starter switch position.

**NOTE:** *If light is left "ON" for a long time while the engine is not running, the battery will be discharged.*

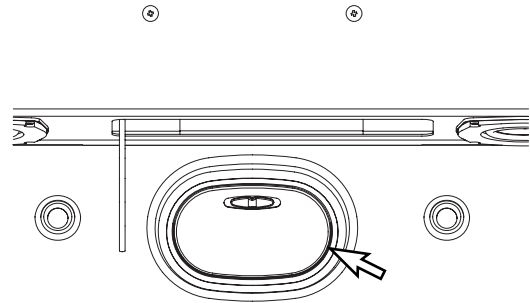

FG000417

Figure 136

## Pilot Cutoff Switch

When the safety lever is put into the "LOCK" position, the switch deactivates the work levers. With the work levers deactivated, no digging/operational work can be done.

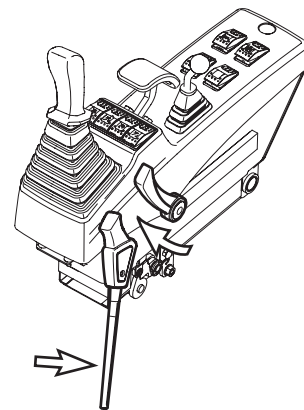

FG006173

Figure 137

## Circuit Breaker

A main circuit breaker is in the battery box. It will automatically cut off in case of an electrical short circuit or overload. This will prevent the electric wiring and components from being burned or damaged.

If the circuit breaker is cut off, check all related circuits, this means something is wrong in the electric circuit.

After maintenance, press the red button for normal operation of circuit breaker.

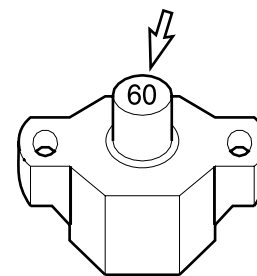

HAAE2110

Figure 138

## Fusible Link

A fusible link is in the battery box.

If the engine does not crank, first check that the starter switch is turned "ON" and that no power is available (No indicator lights will light.). Check that the "A" portion (Figure 139) of the fusible link is not broken or burned through. Replace the fusible link if damage and investigate cause.



### WARNING!

---

**When changing the fusible link, replace the fusible link with the same capacity part. Otherwise, a fire could break out in the wiring harness and/or other components of the circuit. Always use original *DOOSAN* parts.**

---

## Fuse Boxes

There are two fuse boxes (Figure 140) on the left side of the heater box. The fuses prevent electrical devices from overloading or shorting.

A decal attached to the inside of the fuse box access cover indicates the function and amperage of each fuse.

**NOTE:** For a further explanation see "Fuse Boxes" on page 4-77.

Spare fuses are mounted on the inside of fuse box access cover.

Change a fuse if the element separates. If the element of a new fuse separates, check the circuit and repair the circuit.



### CAUTION!

---

**Always replace fuses with the same type and capacity fuse that was removed. Otherwise, electrical damage could result.**

---

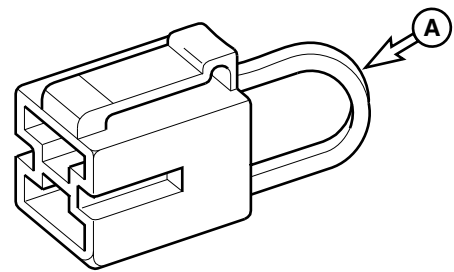

HAAE2120

Figure 139

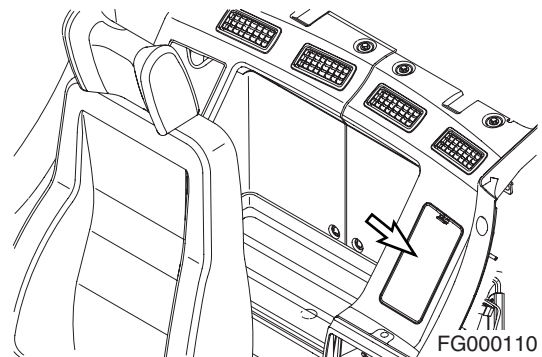

Figure 140

# SEAT ADJUSTMENT

---



Adjust the seat position before starting operations or after changing the operator.

Always fasten your seat belt while operating machine.

Adjust the seat so that the control levers and pedals can be operated freely and easily with the operator back against the backrest.

---

## 1. Forward / Backward Adjustment

Holding lever (1, Figure 141), raise it up, move the seat to the desired position. Release lever to lock the seat in the selected position. Adjustment range is 200 mm (7.9 in).

## 2. Seat Tilt and Height Adjustment

### Forward Tilt

Push lever (2, Figure 141) down to adjust the angle of the front of the seat. There are four positions that it can be set at.

### Rear Tilt

Pull lever (2, Figure 141) up to adjust the angle of the rear of the seat. There are four positions that it can be set at.

### Seat Height

It is possible to move the seat up or down by combining adjustments forward and rear tilt. Adjust the seat according to operator's size and work conditions. Height adjustment is 60 mm (2.4 in).

## 3. Suspension Adjustment

Turning knob (3, Figure 141) to right makes the suspension harder. Turning knob to left makes the suspension softer. Adjust according to operator's weight by checking the weight indicator dial. Adjustment range is from 50 - 120 kg (110 - 265 lb).

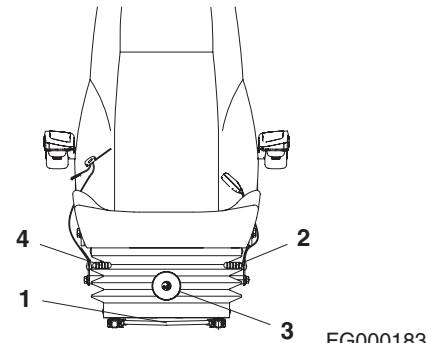

Figure 141

## 4. Reclining Position Adjustment

Pulling up the right lever (4, Figure 141) allows the seat backrest to be moved forward or backward.

Sit with your back against the seat back when adjusting it. If your back is not touching the seat back, the seat back may suddenly move forward.

## 5. Armrest Angle Adjustment

The angle of each armrest can be adjusted by turning a dial (5, Figure 142) on bottom of armrest. When adjusting the angle, manually raise the armrest before turning the dial.

## 6. Lumbar Support Adjustment

A lumbar support is located in the seat back.

Turn the dial (6, Figure 142) counterclockwise to increase the force of the lumbar support

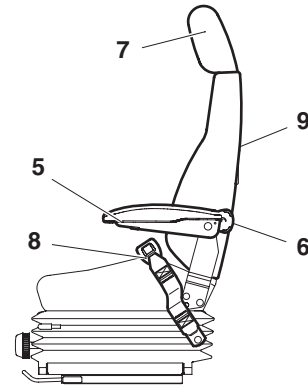

FG000778

Figure 142

## 7. Headrest

The headrest (7, Figure 142) can be adjusted forward/backward and up/down. Move it by holding both sides.

## 8. Seat Belt



---

The seat belt is for the operator's safety and should always be worn. Before driving the machine, adjust the seat to the desired position for maximum comfort and machine control, then fasten the seat belt. Seat belts must be worn across the pelvic region and adjusted snugly to lessen the chance and severity of injury in case of an accident. Never fasten a seat belt across the abdomen.

Under no circumstances should the operator be standing in the cabin when operating the excavator.

Do not adjust the seat position while the vehicle is moving because a loss of control may result. Stop the machine, apply the parking brake, and then adjust the seat.

Always, check the condition of seat belt and belt bracket before fastening it. Do not use it with twists in it. Replace belt or bracket if damaged or worn.

---

## Seat Belt Locking and Unlocking

Insert belt end (1, Figure 143) into the buckle (2). Pull the belt to check that belt end is locked into buckle.

Adjust belt length so that it comfortably tight against the operator's pelvic region (hipbone).

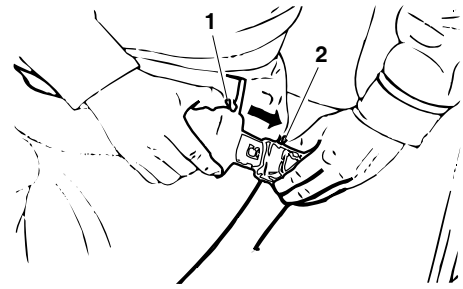

HAOB140L

Figure 143

Press the button (3, Figure 144) in the center of buckle (2) and pull out belt (1) to unlock.

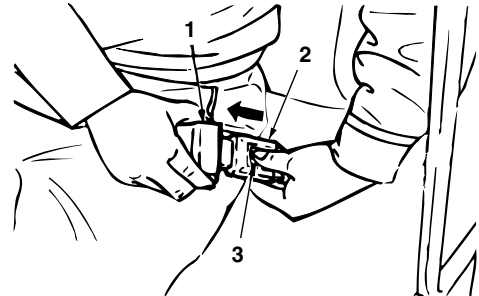

HAOB150L

Figure 144

## 9. Seat Back-pocket

The seat has a seat back pocket. It is used for storing the operation and maintenance manual.

## 10. Left and Right Control Stand Adjustment

For operator's convenience, the right and left control stands and seat can slide together, within a 160 mm (6.3 in) forward or backward travel distance.

Holding lever (10, Figure 145), raise it up, set the seat to desired position. Release lever to lock the seat in the selected position.

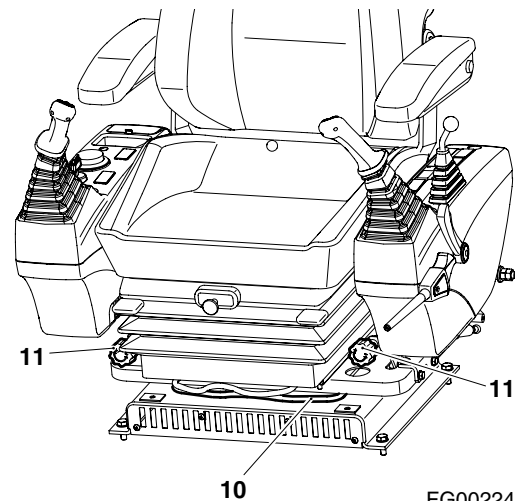

FG002242

Figure 145

## 11. Left and Right Control Stand Height Adjustment

The left and right dials (11, Figure 145) at the lower part of the seat can be turned to adjust the elevation height of each control stand.

It can be used to adjust the height of the control joystick.

## 12. Air Suspension Seat (Optional)

The operator seat is also available with air suspension for even better comfort. The switch (12, Figure 146) in the middle of the seat can be used to adjust the air cushion. If the switch is pressed, the seat become harder, and pulling it out makes the seat softer, when the air is bleed out.

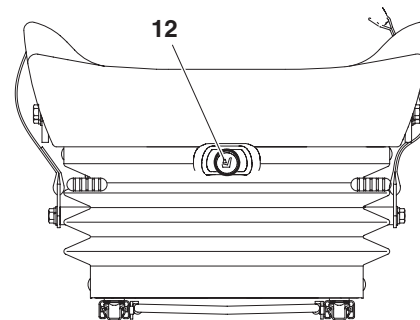

FG000187

Figure 146

## 13. Heating the Operator's Seat (Optional)

The air suspension seat can be heated. The switch on the left control stand is used to warm the seat. When heating is not needed or seat is warmed, turn the switch to "OFF" position.

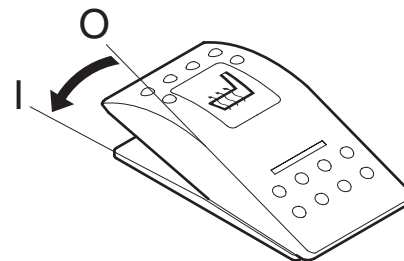

FG000034

Figure 147

# CEILING COVER

**NOTE:** *If the machine is equipped with the optional transparent ceiling cover never use any chemical cleaners on its surface. Only use warm water to wash dust and dirt from its surfaces, and after that, dry it with a soft fabric towel.*

## Opening the Ceiling Cover

1. Lower bucket to ground.
2. Set safety lever (Figure 148) on "LOCK."
3. Pull the lock (1, Figure 149) in front center of ceiling cover and push it up with handle.

## Closing the Ceiling Cover

1. Lower bucket to ground.
2. Set safety lever (Figure 148) on "LOCK."
3. Pull down cover with the handle (Figure 149) so that the lock (1) can be locked in the bracket in the ceiling frame.

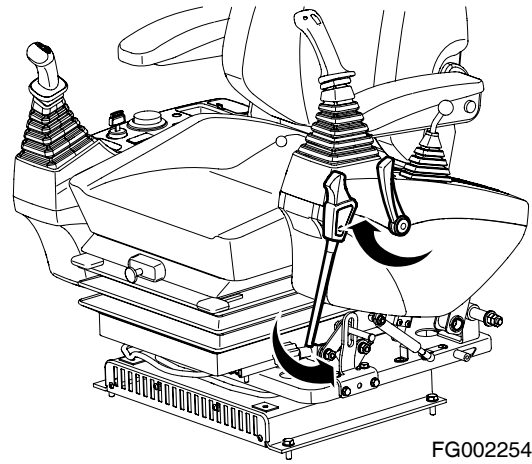

Figure 148

FG002254

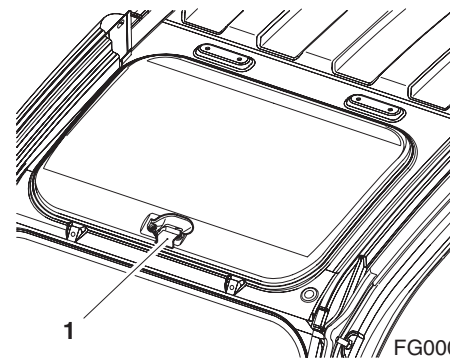

Figure 149

FG000190

# FRONT WINDOWS



## WARNING!

When leaving operator's seat, set the safety lever to "LOCK" position (Figure 150), if not a serious accident could occur by accidentally moving the work levers.

### Front Upper Window

The front upper window can be housed in the cabin's ceiling.

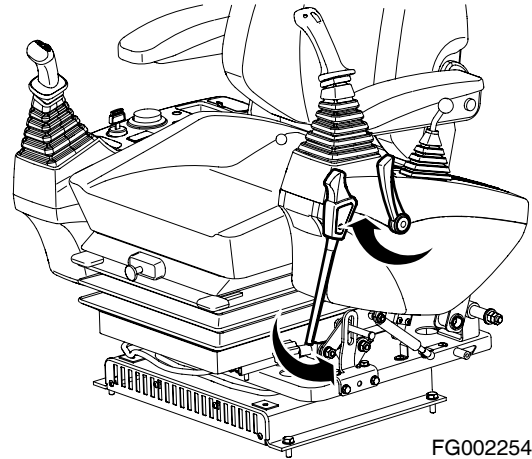

Figure 150

FG002254

### Opening the Window



## WARNING!

When stowing front window in the cabin roof, make sure both release levers (1, Figure 151) are latched.

1. Lower bucket to ground.
2. Set safety lever (Figure 150) on "LOCK."
3. Set engine speed control dial to "LOW IDLE." Allow engine to idle for three - five minutes.
4. Shut down engine by turning key to "O" (OFF) position.
5. Hold the window handles (1, Figure 151), then pull the lock levers (2) to release the lock. The top of the front window will come out.
6. Pull window up, and push it against lock pin at the rear of the cabin. Make sure that it is securely latched.
7. Check that lock levers are securely latched in the lock position.

**NOTE:** When the front upper window is open, never extend your head or body through the window frame.

**NOTE:** If the window happens to fall with a strong impact against the machine, while some part of your body is extended out of the cabin, it may result in bodily injury.

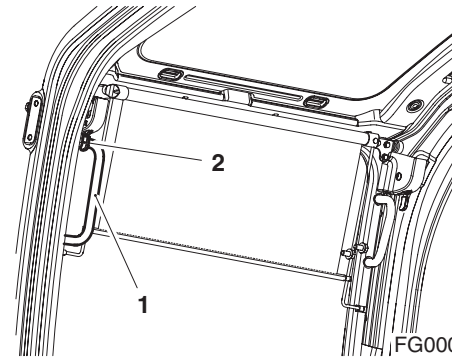

Figure 151

FG000192

## Closing the Window



**Be careful that your hands are not caught in window frame.**

1. Lower bucket to ground.
2. Set safety lever (Figure 150) on "LOCK," and shut down engine.
3. Holding upper handles (1, Figure 152) of front window with left and right-hand, pull lock levers (2, Figure 152) to release the lock.
4. Push window forward, and lower it slowly.
5. When the bottom of the window, reaches the top of the front bottom window, push the front window to engage the lock (2, Figure 151).
6. Check that lock levers are securely latched in the lock position.

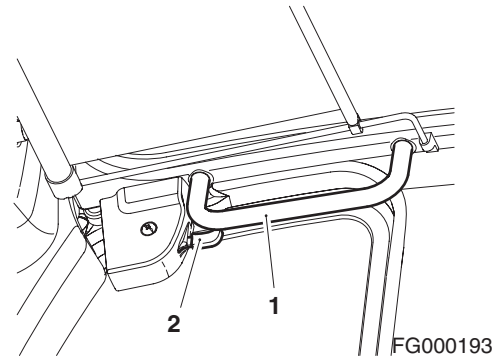

**Figure 152**

FG000193

## Front Bottom Window

The front bottom window can be removed and stored in the rear of the cabin.

1. After stowing the front upper window in the cabin ceiling, remove bottom window (1, Figure 153) from cabin in direction of the arrow.
2. Set bottom window in rubber holders (2, Figure 154) behind operator's seat. Secure window with left and right knobs (3) with push button (4).

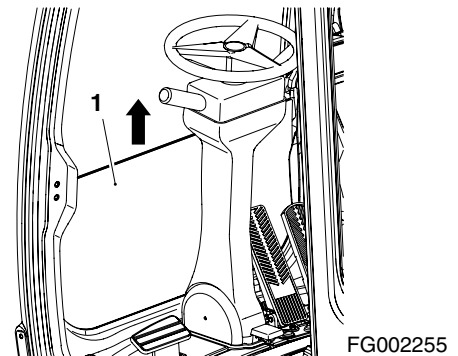
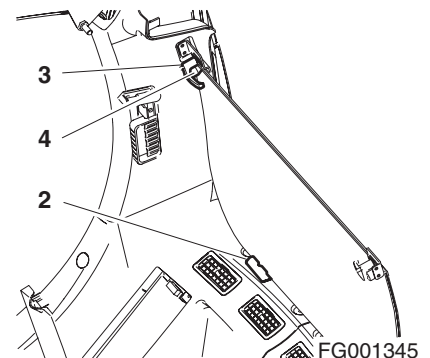

**Figure 153**

FG002255



**Never have wet hands when handling a window. Never drop window or let it come into contact with other parts of the machine.**



**Figure 154**

FG001345

# DOOR SIDE LATCH

1. The door side latch (1, Figure 155) is used to secured the door to the side of the cabin when it is opened.

**NOTE:** *Keep the door closed and locked when machine is not in use.*

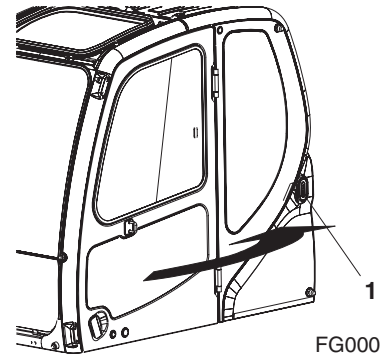

Figure 155

FG000196

2. To release door from side of cabin, push the latch lever (2, Figure 156) down. The latch lever is to the left of the operator's seat.

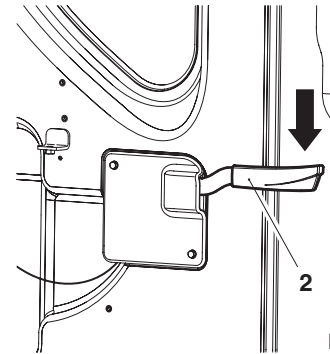

Figure 156

FG000673

# CABIN STORAGE COMPARTMENTS

There are two storage compartments behind the operator's seat. The large compartment (1, Figure 157) is for storing nonperishable items.

The covered other one (2, Figure 157) is interconnected with the air conditioner. So, it can be supplied with either warm or cool air when air conditioner is turned "ON."

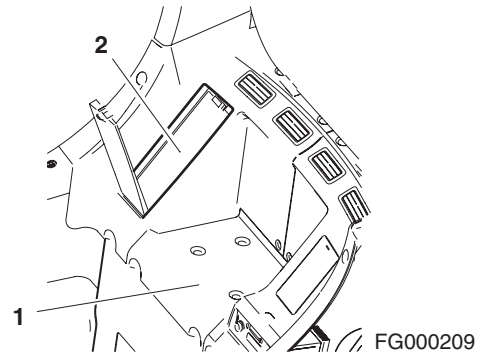

Figure 157

There is a separate small tray (3, Figure 158) on the right side of operator's seat.

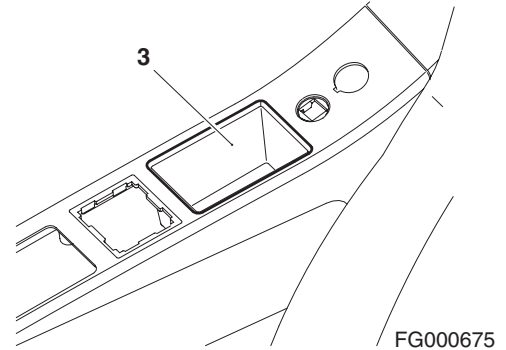

Figure 158

# ASHTRAY

An ashtray (1, Figure 159) is to the right side of the operator's seat on the side of the cabin. Always close ashtray after putting out a cigarette.

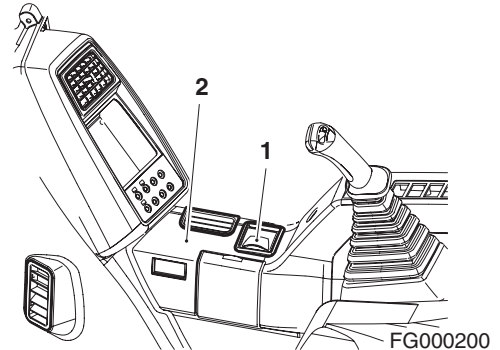

Figure 159

# SUN VISOR

The sun visor can be used to reduce the amount of sunlight coming through the front window and ceiling.

When wanting to reduce the amount of sunlight coming in the front window, pull bar (1, Figure 160) down.

When not wanting protection, hold the bar with left-hand and push the release button (2, Figure 160) with right-hand. This will allow the visor to retract.

**NOTE:** *Do not allow the visor to roll back up without holding it. Not holding it may result in damage to the visor and retract mechanism.*

Ceiling sun visor (3, Figure 161) slides forward and backwards. Move it with handle (4) on each side.

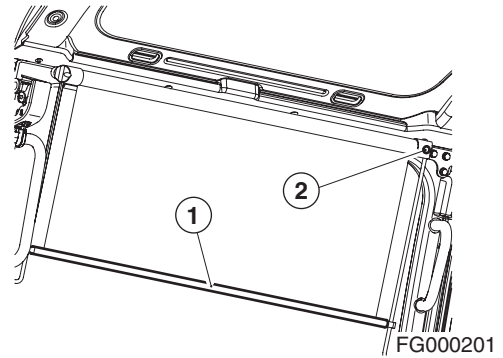

Figure 160

FG000201

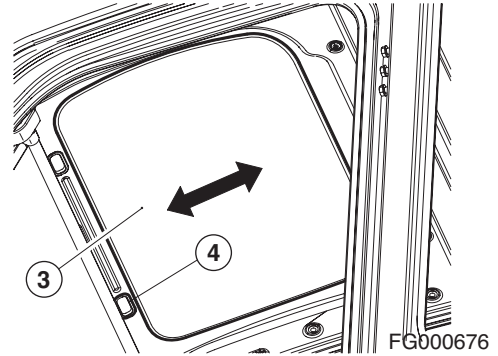

Figure 161

FG000676

When opening the ceiling cover (if equipped), push the sun visor into its compartment (Figure 162).

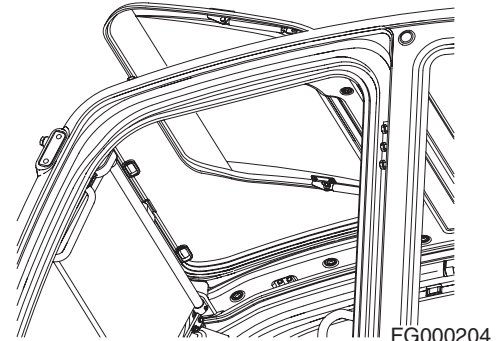

Figure 162

FG000204

# HANGER

A hanger (1, Figure 163) is located on the upper left side of the operator's compartment.



**WARNING!**

Do not hang anything that will easily fall down, or will impair your view out of the cabin.

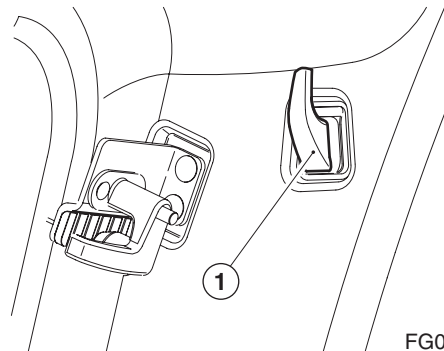

Figure 163

FG000210

## CUP HOLDER

There is a cup holder on the right side of the compartment (1, Figure 164). Open the access cover and lower it to a horizontal position.

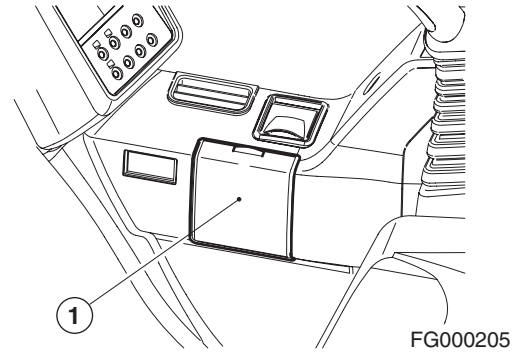

Figure 164

## DOOR WINDOW HOLDER

When the machine is being operated with the cabin door window opened, window vibration can be reduced by tightening knob (1, Figure 165) against the window.

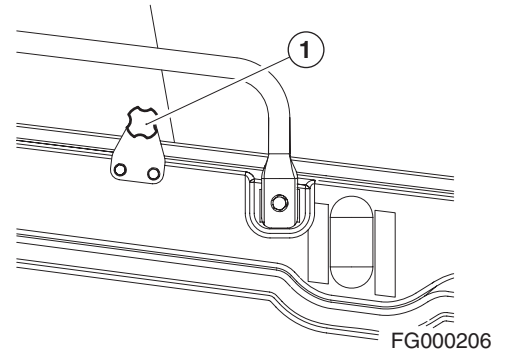

Figure 165

## EMERGENCY GLASS BREAKING TOOL

The excavator is equipped with a glass breaking tool. It is to the upper right corner of the cabin. This tool can be used in case of an emergency situation which requires the breaking of glass to exit from the cabin. Grip the handle firmly and use the sharp point to break the glass.

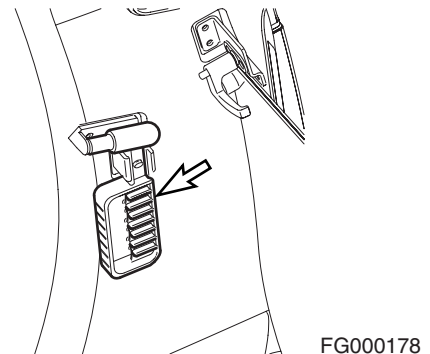

Figure 166



**WARNING!**

**Protect your eyes when breaking the glass.**

# MISCELLANEOUS ACCESS COVERS AND DOORS

## Side Door

Open the side access door and slide prop rod (1, Figure 167) in slot (2) until it locks at the end of slot.

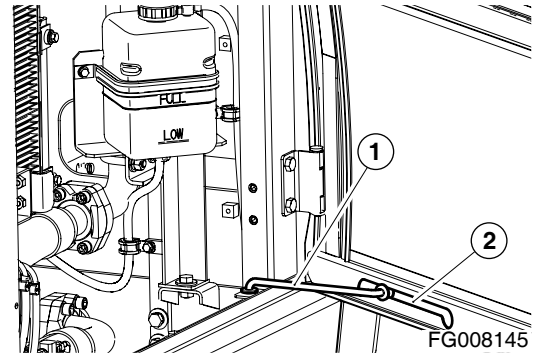

Figure 167

## Battery Box Door

### Opening

Open door until locking device (1, Figure 168) latches.

### Closing

While holding door, press locking device to release lock and close door.

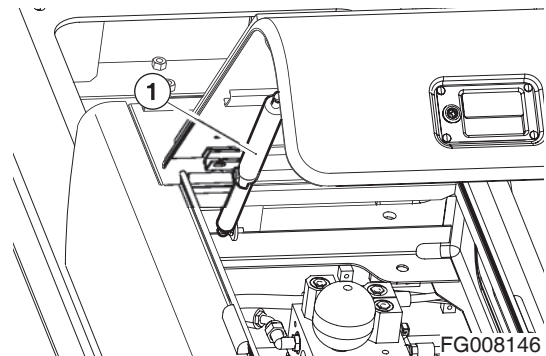

Figure 168

## Engine Cover

Open the cover and slide prop rod (1, Figure 169) in the slot (2) until it locks in notch at the end of slot to support the cover.

To close cover, move end of prop rod out of notch so it can slide in slot.

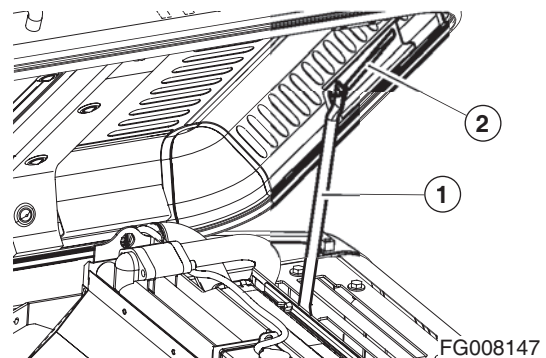

Figure 169

## Dozer Cylinder Protection Cover

Unlock chain (Figure 170) connection between dozer cylinder protection cover and chassis frame out of this chassis frame.

Completely open the dozer cylinder protection cover.



### CAUTION!

---

In order to avoid malfunction when opening dozer cylinder protection cover, you must work it after fixing the facilities on a planar ground surface and then putting down the dozer blade. When opening dozer cylinder protection cover, take heed so that the cover would not be shut off by external shock etc.

---

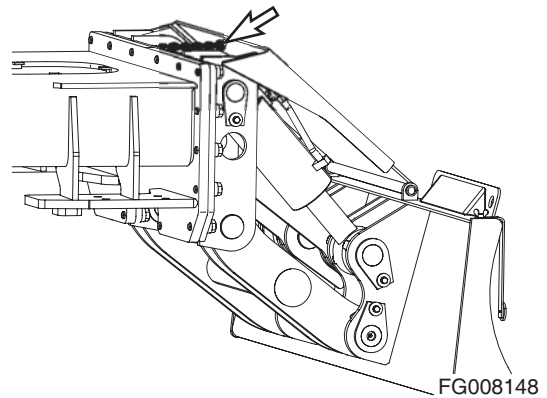

Figure 170

# SWING LOCK PIN AND MECHANISM

This wheel excavator is equipped with a swing lock device, which should be used when transporting or traveling on streets. The device consists of a pin and two holes which must be aligned and through which the pin is placed. This serves to keep the swing device from accidentally moving and causing damage to other vehicles or people in its path.

The swing lock pin is stored in the rear left section of battery compartment (Figure 171).

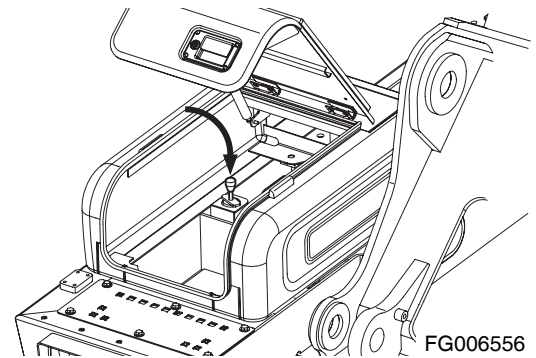

Figure 171

Make sure the upper section is facing forward. Align upper structure of machine with lower frame and make sure holes are in alignment. Insert lock pin into hole (Figure 172) between left boom cylinder and right boom cylinder.

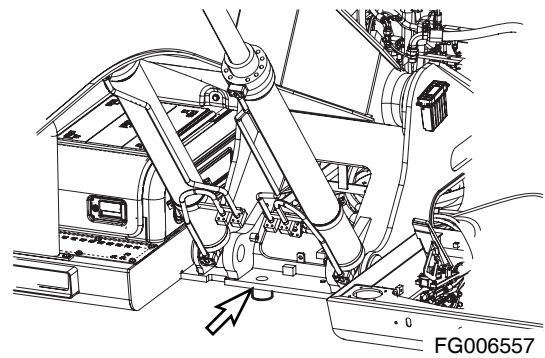

Figure 172

# WHEEL CHOCKS

A pair of wheel chocks are supplied with the machine, there are stored on the lower frame directly below the cabin. When the upper structure is facing the front of the machine.

These wheel chocks should be used at all times when it is necessary to secure the machine for repairs or for transport.

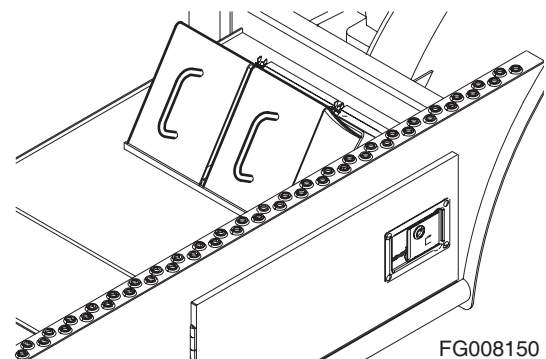

Figure 173

# Operation

## TO HANDLE A NEW EXCAVATOR

All DOOSAN excavators are inspected and adjusted before leaving the factory. However, it is required that the operator follow these steps during the initial break-in period. Failure to follow these steps may result in damage to the equipment or reduced performance.

Hour	Load
For first 50 hours of operation.	Maintain about 80% load of full capacity (Engine rpm: 80% of rated rpm)
After first 50 hours of operation.	Full load

If machine is used at full load before it is broken in, it may affect the life cycle and safe running operations. This could lead to problems later.

- NOTE:**
1. *Check daily for leakage of coolant, fuel, engine oil and hydraulic oil.*
  2. *Inspect all lubricants daily, add appropriate lubricants as required.*
  3. *During operation, monitor all instruments and gauges from time to time.*
  4. *Avoid an extreme engine load.*
  5. *Operate unit at 80% load until engine and all other components are at operating temperature.*
  6. *Check that work equipment is operating normally during operation.*
  7. *Check machine for loose parts or for damage that may have occurred during shipping.*
  8. *Check for loose wiring or terminals, check gauge operation and battery electrolyte level.*

## Lubrication and Filters

1. Change engine oil and replace oil filter after first 50 hours of operation.
2. Change swing reduction device oil after first 250 hours of operation.
3. Change hydraulic oil return filter after first 250 hours of operation.
4. Replace transmission and axle gear oil after first 500 hours of operation.

**NOTE:** *For the replenishment of oil or grease, refer to "Inspection, Maintenance and Adjustment" on page 4-1 of this manual.*

## STARTING AND STOPPING THE ENGINE

### Inspection Before Starting Engine

---



### **WARNING!**

---

**If a flammable materials such as leaves, paper, etc. are allowed to accumulate on high temperature components, such as the engine muffler and turbo, a fire may occur. Fuel, lubricant and hydraulic oil leaks, may cause a fire. If there is anything wrong, perform the appropriate corrective action.**

---

Before starting engine, inspect the following items;

1. Electric system - Check for damaged electric cables, and loose or missing connectors.
2. Fuel system - Drain water and sediment from fuel tank and fuel pre-filter.
3. Hydraulic system - Check for hydraulic oil leaks, damaged tubing and hoses, and interference points of components.
4. Lubrication - Perform all daily and periodic maintenance services. Perform services according to reading shown on hour meter.
5. Safety - Perform a machine walk-around. Make sure that no one is under the machine or performing any maintenance on it, before starting engine.
6. After starting machine - Check that all operational controls and components, are in proper operating condition, and are functioning correctly. Stop operation and correct any malfunction before continuing work.

## Operational Checks Before Starting Engine

### **WARNING!**

When leaving operator's seat, set the safety lever and stand on "LOCK" (Figure 1) position, if not a serious accident could occur by accidentally moving the travel or work levers.

1. Set safety lever and stand on "LOCK" (Figure 1).
2. Fasten seat belt. Check for proper operation and condition.
3. Set all operation levers in "NEUTRAL".

**NOTE:** *Be careful not to touch any switches when starting engine.*

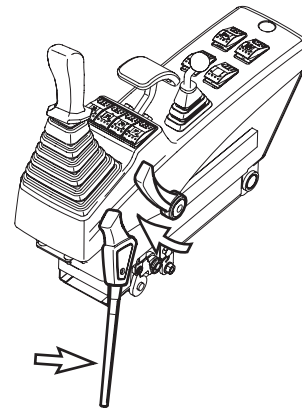

Figure 1

FG006173

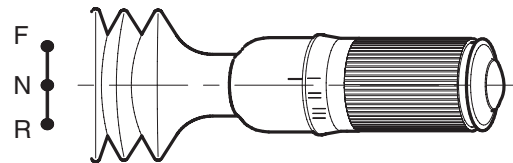

Figure 2

FG002266

4. Set parking brake switch to the "I" position. This will ensure that the parking brake is "APPLIED".

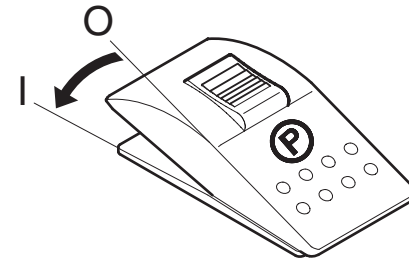

Figure 3

FG002178

5. Rotate the starter switch to the "I" (ON) position (Figure 4). Check all indicator lights. A warning buzzer will sound for about 2 seconds. After 2 seconds, all lights except the following will turn "OFF".

- Engine coolant temperature gauge
- Charging warning light
- Fuel gauge
- Hydraulic oil temperature gauge
- Engine oil pressure warning light
- Engine rpm (0 rpm) digital readout

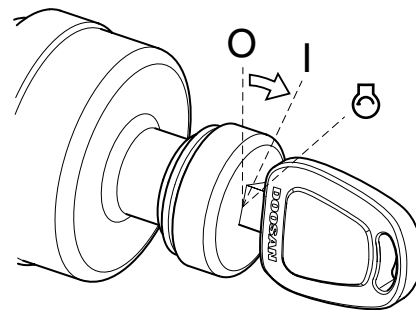

Figure 4

FG000084

**NOTE:** *If all of the indicator lights do not come "ON" when the key is first turned, there is a problem.*

A warning buzzer will sound for about 2 seconds.

The sound of the engine control motor may be heard while it rotates to the correct starting position.

## Engine Start



### WARNING!

**Start the engine after sounding horn and making sure that there are no people or obstacles in the area.**

1. Perform all steps in "Operational Checks Before Starting Engine" on page 3-3.
2. Set engine speed control dial slightly above "LOW IDLE" (Figure 5).
3. Sound horn.

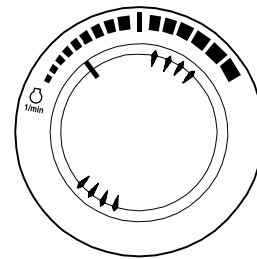

HAOB34L

Figure 5

4. Enter password.

**NOTE:** *If the security system is "LOCKED", a four-digit password will be required to start the engine. If the system is "UNLOCKED", no password will be required and this display screen will not appear.*

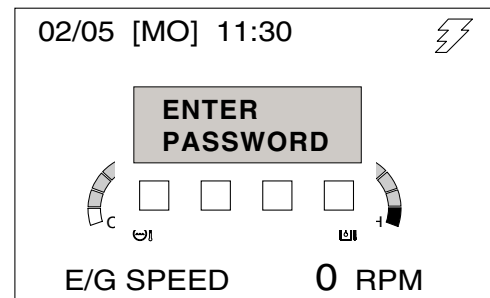

FG001445

Figure 6

- Turn starter switch to "O" (START) position (Figure 7). Engine should start in approximately 5 seconds.

---

**! WARNING!**

---

**If the engine does not start after approximately 15 seconds of cranking, release the starter switch. Wait about 5 minutes and repeat above step.**

---

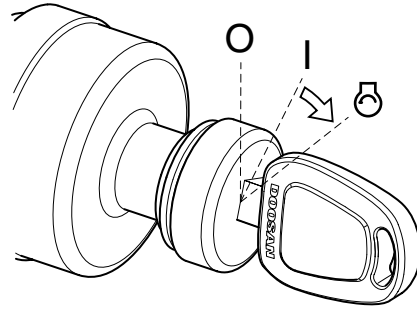

FG000085

Figure 7

- After engine has started, release key. Key will return to the "I" (ON) position (Figure 7).
- Follow procedures in "Hydraulic System Warm-up" on page 3-10.

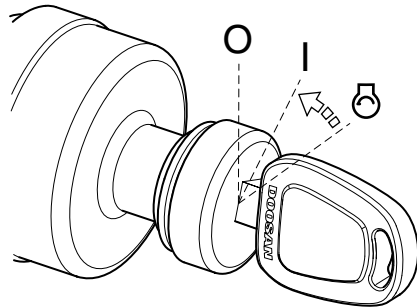

FG006181

Figure 8

- After warming unit, check all operating indicators to make sure that all engine systems (oil pressure, coolant, etc.) are in the normal operating range. If any problems are noticed, shut down engine. Normal indicators are:

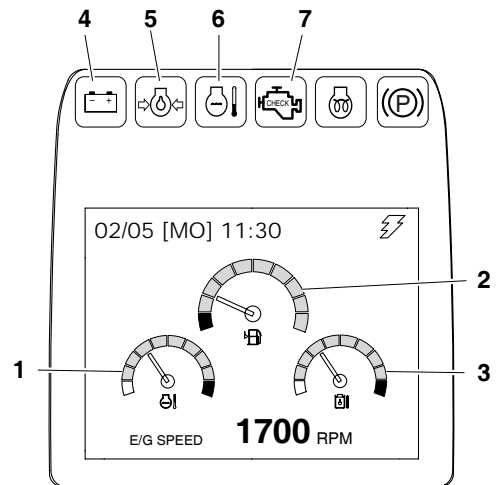

FG007104

Figure 9

No.	INSTRUMENT PANEL LIGHT OR GAUGE	INDICATOR READING
1	Engine Coolant Temperature Gauge	Blue Range
2	Fuel Gauge	Blue Range
3	Hydraulic Oil Temperature Gauge	Blue Range
4	Charging Warning Light	OFF
5	Engine Oil Pressure Warning Light	OFF
6	Engine Coolant Temperature Warning Light	OFF
7	Engine Check Warning Light	OFF

9. Check color of exhaust smoke.
  - No color or light blue - Engine is running in good condition.
  - Black - Incomplete combustion. Check cause.
  - White or dark blue - Engine is burning engine oil. Check cause.
10. Check for usual engine vibration and noises. If any are heard or felt, investigate cause.

**NOTE:** *If engine coolant temperature gauge pointer moves into the red zone, the engine coolant temperature warning light will turn "ON", a warning buzzer will sound, and the engine speed will be automatically reduced. Allow the engine to run at low idle speed until the temperature gauge registers in the blue zone again. When the blue zone is reached, allow the engine to idle for an additional three - five minutes before shutting down the engine. If not allowed to idle, heat surge may develop which will damage the engine. Allowing the engine to idle will dissipate heat. Check the coolant level, look for a loose fan belt, inspect for debris around radiator, and so on.*

## Cold Weather Starting

---



### **WARNING!**

---

**DO NOT USE STARTING FLUIDS.** The preheat system could cause the starting fluid to explode. Starting fluids should never be used.

---

1. Perform all steps in "Operational Checks Before Starting Engine."
2. Set engine speed control dial slightly above "LOW IDLE" (Figure 10).
3. Sound horn.

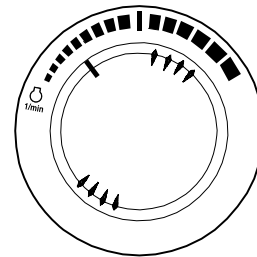

**Figure 10**

HAOB34L

- Turn starter switch to the "I" (ON) position (Figure 11). When preheat cycle is completed, the preheat indicator light (1, Figure 12) will turn "OFF".

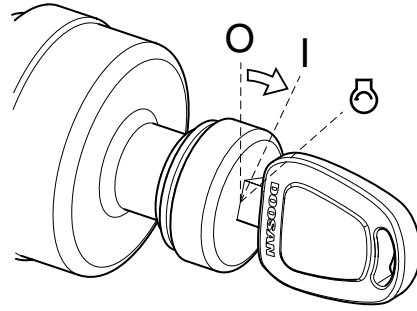

FG000084

Figure 11

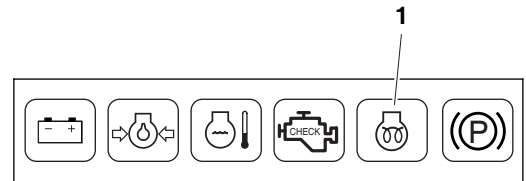

FG007105

Figure 12

- After the preheat completion, immediately turn starter switch to "O" (START) position (Figure 13). Engine should start in approximately five seconds.



## WARNING!

**If the engine does not start after approximately fifteen seconds of cranking, release the starter switch. Wait about five minutes and repeat above step.**

- After engine has started, release key. Key will return to the "I" (ON) position (Figure 13).
- After the engine starts, check all operating indicators to make sure that all engine systems (oil pressure, coolant, etc.) are in the normal operating range. If any problems are noticed, shut down engine.
- Follow "Hydraulic System Warm-up" procedures in this section. (See page 3-10)

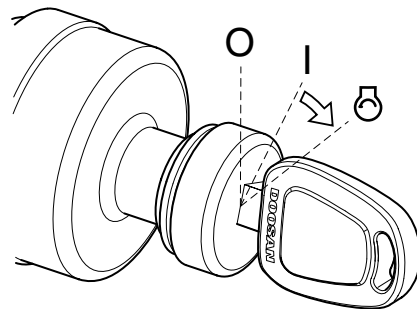

FG000085

Figure 13

## Starting Engine With a Booster Cable

### **WARNING!**

1. An explosive gas is produced while batteries are in use or being charged. Keep flames or sparks away from the battery area.
2. Charge batteries in a well ventilated area.
3. Always wear eye protection when starting a machine with jumper cables.
4. Improper jump starting procedures can cause an explosion resulting in personal injury.
5. Jump start vehicles on dry ground or concrete. Do not jump start the machine on a steel floor, because the floor is always grounded.
6. When starting from another machine, make sure the machines do not touch.
7. Always connect the auxiliary battery positive (+) terminal too depleted battery positive (+) terminal first. Then connect auxiliary battery negative (-) terminal to the frame of the depleted battery machine second.
8. Connect positive cable first when installing cables and disconnect the negative cable first when removing.



Figure 14

HAOA440L

### **IMPORTANT**

The machine has a 24V (-) negative ground electrical system. Use the same capacity 24V booster batteries when jump starting engine.

If the batteries are drained during starting procedures, jump start engine using auxiliary or booster batteries according to the following procedure;

#### **Connecting the Booster Batteries**

1. Shut down engine of the machine on which booster batteries (3, Figure 15) are mounted.
2. Connect one end of red cable (1, Figure 15) to the positive (+) terminal of the machine batteries (4), and the other end to the positive (+) terminal of the booster batteries.
3. Connect one end of black cable (2, Figure 15) to the negative (-) terminal of the booster batteries (3), and then make ground connection to the upper frame (5) of the machine to be started with the other end of black (-) cable (2, Figure 15). When making the last connection to upper frame, be sure to connect the cable end as far away from

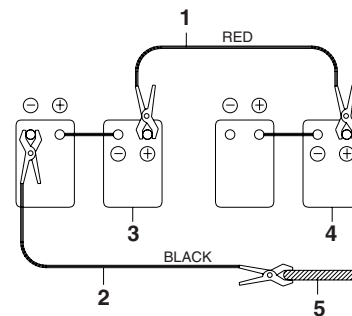

Figure 15

ARO0440L

the machine batteries as possible. DO NOT CONNECT DIRECTLY TO THE NEGATIVE BATTERY TERMINAL.

4. Start the engine.

#### **Disconnecting the Booster Batteries**

1. Disconnect black negative (-) cable (2, Figure 15) from the machine frame (5) first.
2. Disconnect the other end of black negative (-) cable (2, Figure 15) from the booster batteries (3).
3. Disconnect red positive (+) cable (1, Figure 15) from the booster batteries (3).
4. Disconnect red positive (+) cable (1, Figure 15) from the machine batteries (4).

# Hydraulic System Warm-up



If a problem or abnormal operation occurs, immediately shut down engine. Allow excavator to reach normal operating temperature before starting work, especially in cold weather.

The correct operating temperature of the hydraulic oil is 50° - 80°C (120° - 175°F). Make sure to follow the procedures listed here for hydraulic fluid warm-up.

1. Run engine for approximately five minutes set at the middle of the speed range, without a load.

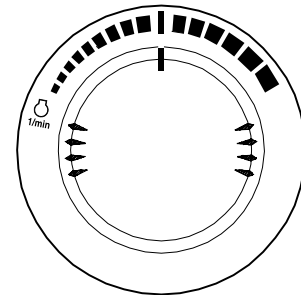

Figure 16

HAOB410L

2. Set safety lever (Figure 17) and stand on "UNLOCK" position.

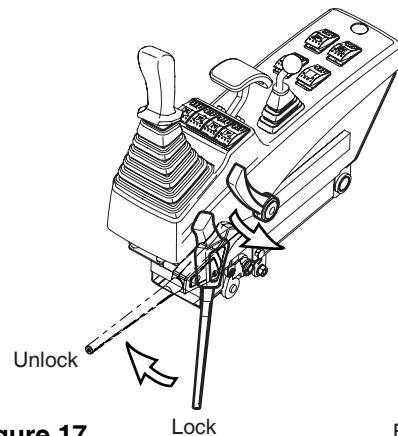

Figure 17

Lock

FG007022

3. Slowly cycle boom, arm and bucket cylinders about five times without a load to circulate the oil through the system. Do this for five minutes.
4. Check for clearance and fully raise the front attachment. Swing clockwise 3 revolutions. Swing counterclockwise 3 revolutions.
5. Travel forward and reverse at low speed for two revolutions of the drive wheel.

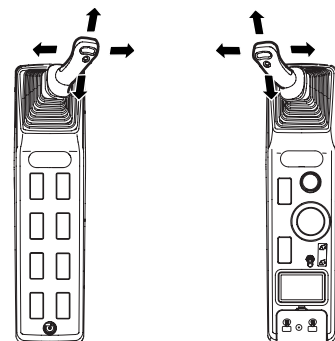
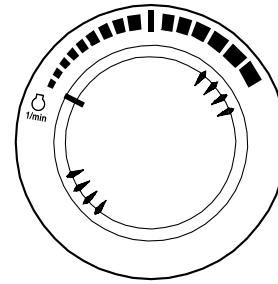

Figure 18

FG000380

# Hydraulic System Warm-up – Cold Weather

1. Run engine at "LOW IDLE" (no load) for five minutes (Figure 19).



HAOB290L

Figure 19

2. Run engine for approximately five minutes set at the middle of the speed range, without a load (Figure 20).

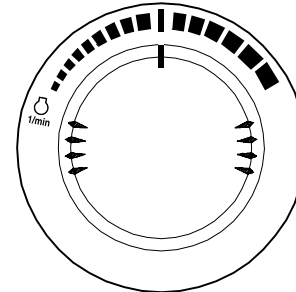

HAOB410L

Figure 20

3. Set safety lever (Figure 21) and stand on "UNLOCK" position.

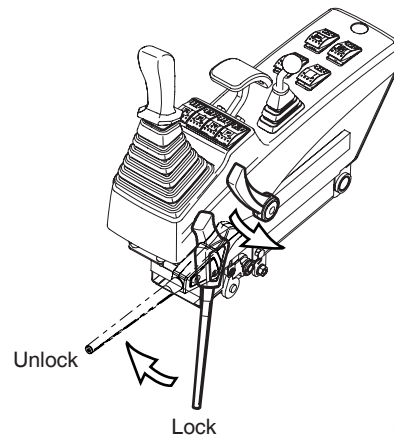

FG007022

Figure 21

4. Slowly cycle boom, arm and bucket cylinders about five times without a load to circulate the oil through the system. Do this for five minutes.

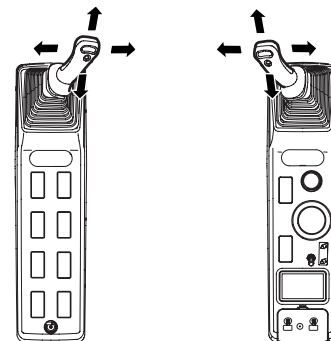

FG000380

Figure 22

5. Set engine speed control dial to "HIGH IDLE" (Figure 23).
6. Repeat Step 4 for five minutes. If working speeds continue to be slow, continue to operate, but use extreme caution because the machine function may be erratic.
7. Check for clearance and fully raise the front attachment. Slowly swing clockwise 3 revolutions. Slowly swing counterclockwise 3 revolutions.
8. Travel forward and reverse at low speed for two revolutions of the drive wheel.

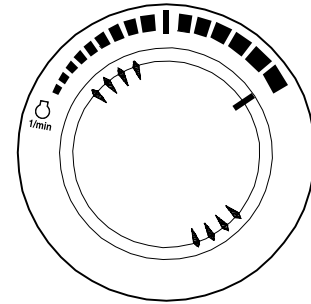

HAOB550L

Figure 23

## Engine Shut Down

**NOTE:** Allow engine to idle for three - five minutes before shutting down the engine. If not allowed to idle, heat surge may develop which will damage the engine. Allowing the engine to idle will dissipate heat.

1. Park excavator on level and firm ground.
2. Lower front end attachment to ground and make sure all operating controls are in "NEUTRAL."
3. Set safety lever on "LOCK" position, and raise the lift stand by pulling up lever (1, Figure 25).

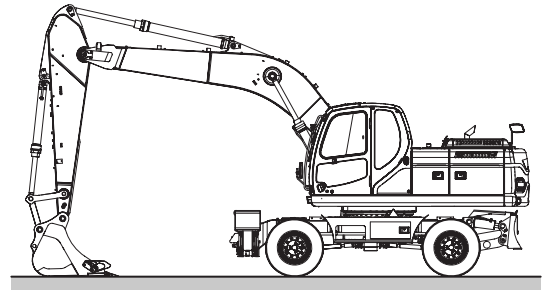

FG006558

Figure 24

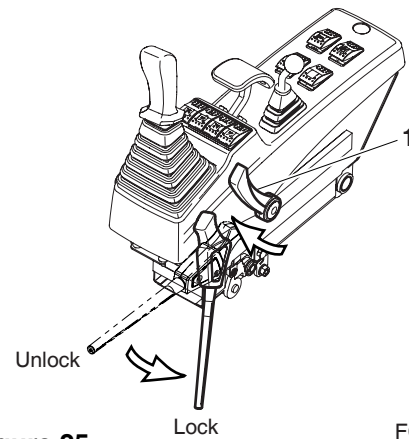

FG007113

Figure 25

4. Set engine speed control dial to "LOW IDLE" (Figure 26). Allow engine to idle for three - five minutes.

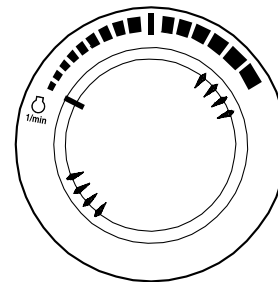

HAOB290L

Figure 26

5. Shut down engine by turning key to "O" (OFF) position (Figure 27).
6. Remove key from starter switch.

## Check and Confirmation After Stopping Engine

1. Repair excavator, if there are any coolant or oil leaks.
2. Inspect front attachment and chassis frame for abnormal appearances. Correct any problems.
3. Fill fuel tank.
4. Get rid of any accumulated flammable materials such as leaves and paper etc. in engine compartment.
5. Clean all mud, etc. from chassis frame and tires. Make sure that all steps and hand holds are clean, and that the operator's compartment is clean.

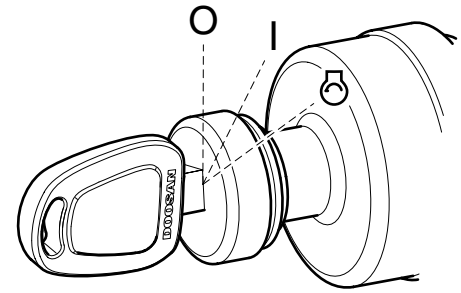

FG000175

Figure 27

# SAFETY LEVER

---

## **WARNING!**

---

When stopping engine or leaving the operator's seat, "LOCK" the safety lever, otherwise, a serious accident may occur by accidental movement of travel and work levers.

Whenever leaving the operator's seat, make sure the engine is shut down and the safety lever is "LOCKED."

Especially, when adjusting the seat, control stands, or raising the front window, lower window, or ceiling cover, never forget to lock the safety lever in its "LOCKED" position.

---

Be careful not to move the work levers (joysticks) when moving safety lever.

1. Push safety lever (Figure 28) down into the "LOCKED" position. When safety lever is in the "LOCKED" position, the front attachment swing, dozer and outrigger movement will be disabled even though a lever is moved. ("LOCKED" condition is made by safety function separately constituted in case also of stand fitting)

**NOTE:** Lower bucket (front attachment) to ground. Place all control levers in "NEUTRAL" and shut down engine, before using the safety lever.

2. Set safety lever and stand (Figure 29) on "RELEASE/UNLOCK" position, by pulling it up before starting work. (Whereas stand also must become release condition by your lowering the stand for your normal work condition)

**NOTE:** When the engine is not running, but the safety lever is "RELEASED" and the starter key is tuned "ON", moving the work levers (joysticks) may result in movement. The charged accumulators in the system will provide pilot pressure for control valve spool movement.

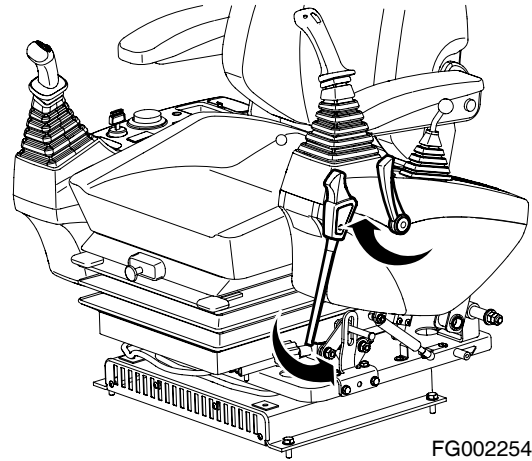

FG002254

Figure 28

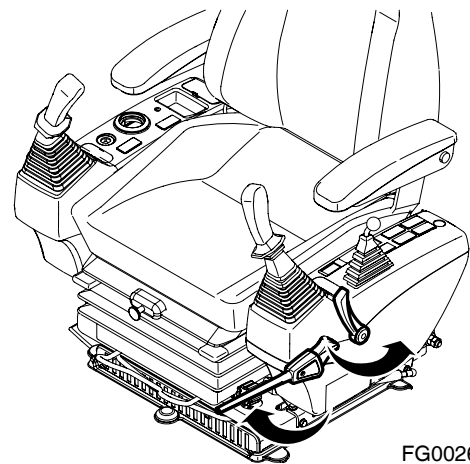

FG002651

Figure 29

# TRAVEL

---



## WARNING!

---

1. Make sure to read and understand all operating controls, Cautions, and Warnings before traveling.
  2. Obey all traffic rules and regulations.
  3. Do not travel faster than conditions allow.
  4. Make sure to follow all local and state rules and regulations regarding over the road travel of construction equipment.
  5. Before putting the machine into gear, make sure in which direction the machine is facing. Locate the front section of the excavator and select the appropriate gear for the direction of travel desired.
  6. Before moving, make sure that there are no personnel in the way or on the machine. Sound the horn to alert workers that you are about to move the machine.
  7. Be sure the path is clear during travel, especially when traveling in reverse gear.
  8. If an alarm buzzer sounds or a warning light turns "ON", stop immediately and determine the cause of the problem.
  9. If an unusual sound or smell is noticed, immediately stop the machine and determine the cause of the problem.
  10. Avoid sudden stops or turns.
  11. Remain in the slowest travel lane possible.
  12. The machine is top heavy. Make sure to make turns at a slow speed.
  13. Take extreme caution when traveling on road shoulders or narrow streets.
  14. Never jump off the machine while it is moving.
  15. Before leaving the operator's seat, make sure to lock out all control systems and shut down the engine to avoid accidental activation.
-

## Before Traveling

1. Check all tires to make sure that they are properly inflated and are not damaged.
2. Make sure that all excess mud, stone, etc. has been removed from the tires.
3. Fully raise and secure all outriggers and the dozer blade, be sure to lock the outrigger legs (Figure 30).
4. Make sure that the upper section is facing forwards.
5. Store the front attachment in the "TRANSPORT" position and set the Function Lock in the "TRAVEL" position. (See Figure 31 on page 3-16)
6. Set the ram cylinder toggle switch in the "UNLOCK" position.
7. Before moving the excavator, make sure that the swing lock pin has been engaged. (See "Swing Lock Pin and Mechanism" on page 2-76.) This will prevent the excavator from accidentally rotating during traveling.

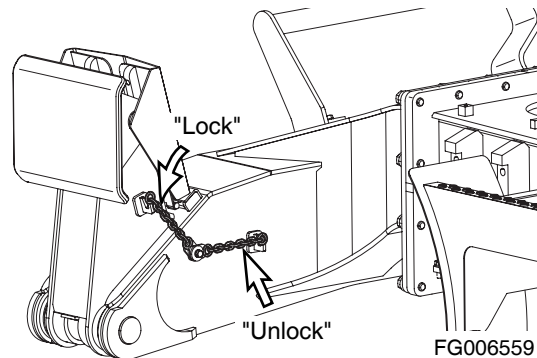
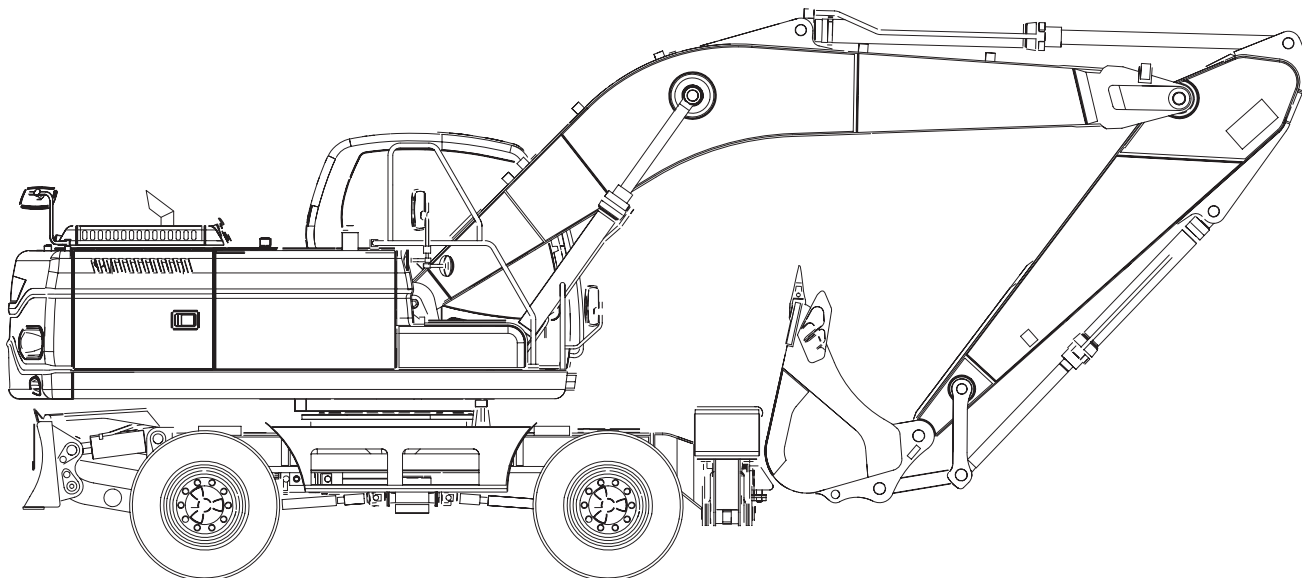

Figure 30



FG006560

Figure 31

## Over the Road Traveling Procedures

1. Make sure that the "Brake Oil Pressure" warning light is "OFF".
2. After making sure that the front attachment is facing forward, release the parking brake.
3. Using the right-hand control arm, select either forward or reverse travel direction and step on the accelerator pedal.

**NOTE:** *The accelerator pedal functions in two ways. If the manual engine speed control dial is at the lowest setting, the accelerator pedal controls both engine speed and a hydraulic proportioning valve that controls the actual travel speed. If the manual engine speed control dial has been set to a higher rpm, the accelerator pedal functions only as a hydraulic proportioning valve control, enabling control of only travel speed and not engine rpm.*

4. Test the brakes before beginning over the road travel.
5. During forward motion you can shift from speed range II to speed range III. Downshifting from speed range III to speed range II should not be done if the machine is traveling at a high rate of speed. Damage to the transmission could result.



### **WARNING!**

---

**Don't change to creep speed during running in low or high speed.**

**It cause a damage to equipment.**

**You should select creep speed after stopping an equipment.**

**In normal travelling drive in low or high speed.**

---

6. To stop the machine, slowly release the accelerator pedal. The dynamic braking action of the machine's momentum against the engine's back pressure will begin to slow the machine. Step on the brake to bring the machine to a full and controlled stop.

---

### **IMPORTANT**

---

**If the engine speed is controlled by the manual engine speed control dial, when the machine comes to a stop, the engine will continue to run at the preset rpm. If the engine speed is being controlled by the accelerator pedal, it will decrease and the machine will slow down as the pedal is released.**

---

**NOTE:** As the brake pedal is applied, and if it is pressed all the way to the floor, a mechanical lock will engage and hold the pedal in the fully applied position (1, Figure 32). Step on the release lever and the brake pedal will return to the upright position.

- After traveling a long distance, the front attachment, outriggers or dozer blade may begin to drift due to normal internal hydraulic leakage. Position the machine in a safe location and move the function lock to the full front function position and reposition the front attachment, outriggers or dozer blade.

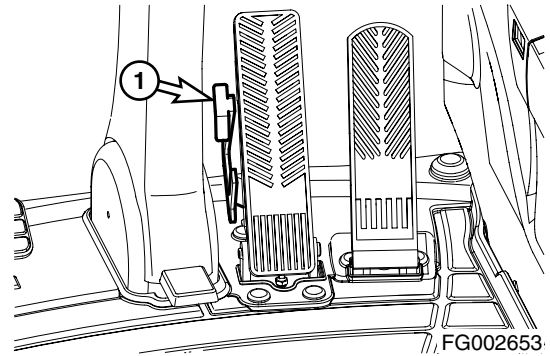

Figure 32

## Traveling On A Work Site

### **WARNING!**

When traveling, keep bucket from 200 - 300 mm (8 - 12 in) above ground.

Do not travel backwards on a slope.

Never turn or travel crosswise on a slope.

Choose a safe alternate route before climbing a slope.

If excavator starts to slip or becomes unstable, lower the bucket immediately into the ground using it as a brake.

Avoid working on slopes, because there is a danger of overturning by coming unbalance while swinging and performing front attachment operations.

It is very dangerous to swing towards bottom of slope with a loaded bucket.

In unavoidable cases level the slope with fill soil, to make the vehicle as horizontal as possible.(Figure 33)

Do not travel on slopes over 30° due to turnover danger.

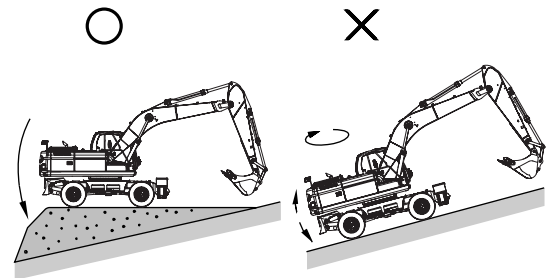

Figure 33

- Avoid obstacles, never drive over them.
- Keep away from the shoulders or edges of slopes or excavations.
- Always travel directly up or down a slope, never sideways.
- Avoid changing directions or sudden starts or stops on a slope.
- On a slope, make sure to fully extend the arm and lower the boom until the bucket is 20 – 30 cm (8" – 12") above the ground. (See Figure 34 on page 3-19.) If the machine starts to slide or slip, lower the bucket to the ground to regain control. If the engine stalls, lower the bucket, make sure that all controls are in the "NEUTRAL" position and restart the engine.

6. Never travel up or down a slope with a vertical angle greater than  $20^{\circ}$ , or sideways on a slope with a vertical angle of greater than  $5^{\circ}$ .

## Traveling On A Slope

1. If the engine stops when traveling on a slope, lower the bucket to the ground, make sure all controls are in the "NEUTRAL" position and restart the engine.
2. Before driving down a slope, test the brakes to make sure that they are fully functional.
3. Never drive down a slope with the transmission in "NEUTRAL."
4. When driving down a slope, allow the dynamic braking action of the machine's momentum against the engine's back pressure to slow the machine. Step on the brake to bring the machine to a full and controlled stop. Do not over use the brakes on a slope or they can burn out.
5. Make sure to fully warm up the engine and the hydraulic system before attempting to travel on a slope.

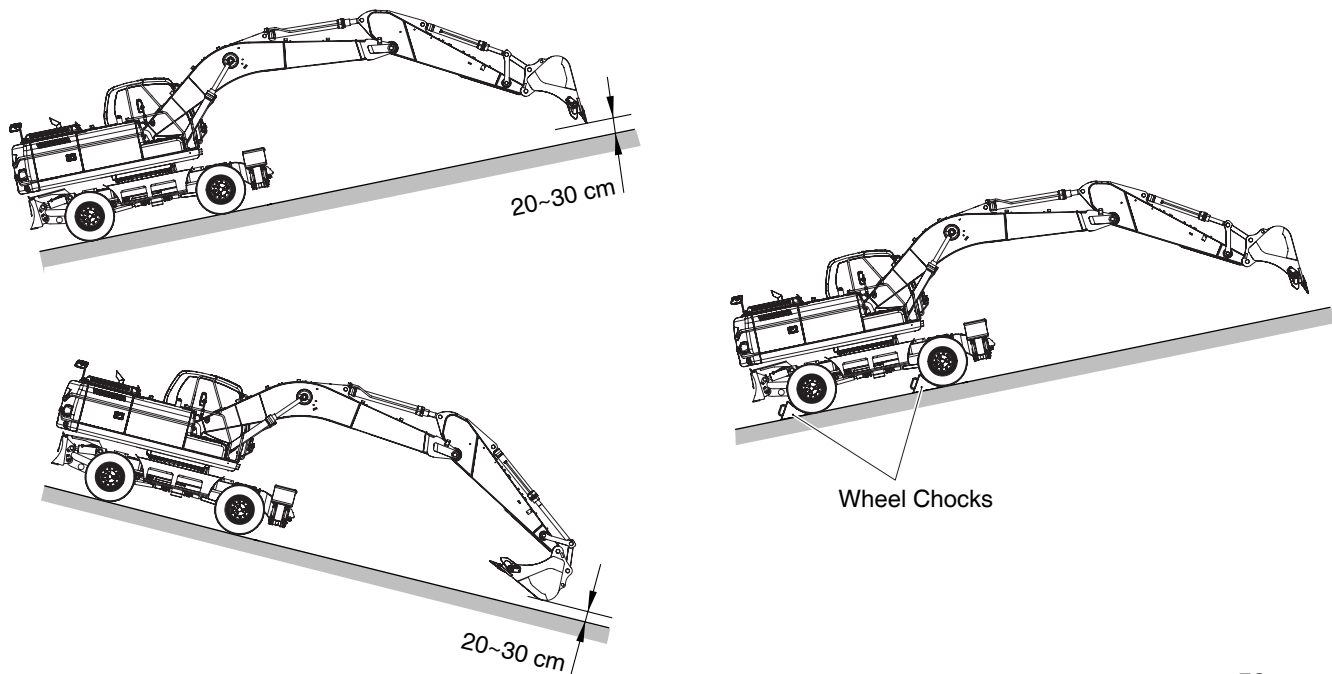

FG006561

Figure 34

## Parking

1. Slowly release the pressure on the accelerator pedal.

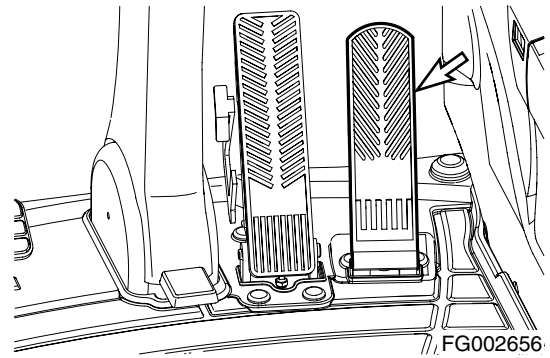

Figure 35

2. Step on the brake to fully stop the machine.

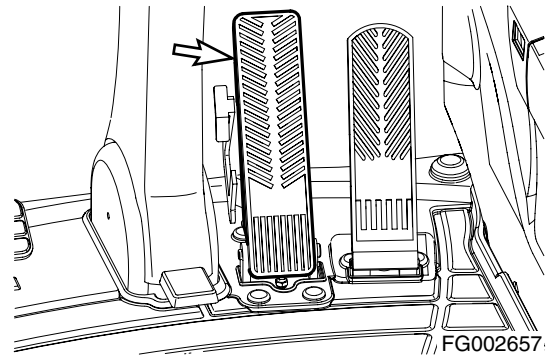
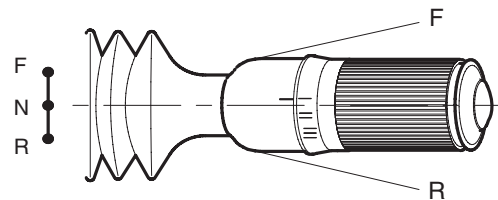

Figure 36

3. Be certain to set the work levers (joysticks) and transmission select lever to "NEUTRAL".



FG002185-2

Figure 37

4. If you are using the manual speed control dial, reduce the engine speed to "LOW IDLE".

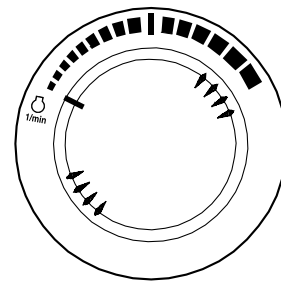

HAOB290L

Figure 38

5. Lower bucket, dozer blade and outrigger to ground.

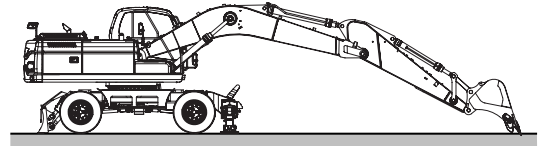

FG006562

**Figure 39**

6. Set parking brake switch to the "I" position. This will ensure that the parking brake is "APPLIED".

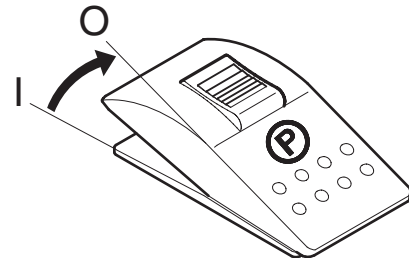

FG002178-1

**Figure 40**

7. Shut down engine by turning key to "O" (OFF) position (Figure 41).
8. Remove key from starter switch.

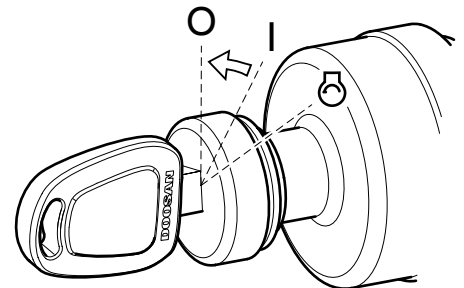

FG008623

**Figure 41**

9. If the machine is parked on a slope, insert the wheel chocks on the downhill side of the wheels to secure the machine. (See Figure 34 on page 3-19.) wheel chocks are supplied with the machine. There are stored on the lower frame directly below the cab. When the upper structure is facing the front of the machine.

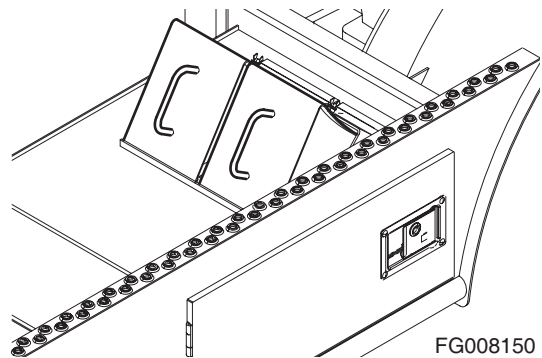

FG008150

**Figure 42**

## Travel Problems

1. If a problem develops during the travel mode, move the machine to the side of the road as safely as possible.
2. Determine the cause of the problem and correct it if possible.
3. If a hydraulic leak develops, lower the bucket and the dozer blade to the ground, shut down the engine, and release the air pressure from the hydraulic tank. Contain the hydraulic fluid if possible.

## Cruise Control

### Engaging Cruise Control



The Cruise Control set button will set only the engine rpm, not road speed. The engine rpm is set by rotating the manual engine speed setting dial.

---

1. Using the foot control pedal, bring the unit to the appropriate travel speed.
2. Rotate the engine speed control dial to match the rpm setting shown on the tachometer. (Figure 43)

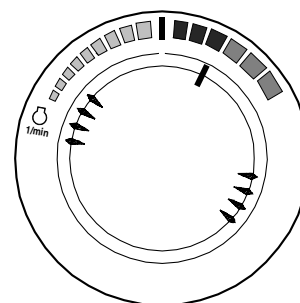

HGB3013L

Figure 43

3. Press the button on the end of the right-hand control arm inwards. (Figure 44) This button will maintain the engine rpm setting dialed in by the manual engine speed control dial. The foot control pedal will not affect this setting.
4. Rotate the engine speed control dial to either increase or decrease travel speed.

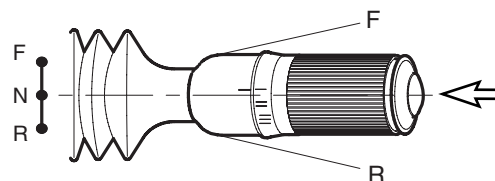

FG002660

Figure 44

### Disengaging Cruise Control

1. Disengage the cruise control by pressing the brake pedal or by shifting the travel direction control lever into "NEUTRAL".

# OPERATING INSTRUCTIONS

## Engine Speed Control

Engine speed can be manually adjusted using the engine speed control dial. Increase engine speed by rotating the control knob clockwise. Decrease engine speed by rotating the control knob counterclockwise.

---

### IMPORTANT

---

**The engine speed control system has been set at the factory and should not require adjustment as part of routine maintenance.**

---

In the event that the automatic speed control system fails, the e-EPOS controls automatically defaults and reduces engine speed. Manual control of engine speed can be done by using either the manual engine speed control dial, which will allow the operator to set and hold a specific engine speed, or the Accelerator Pedal for variable engine speed.

**NOTE:** *If the automatic speed control system has failed, the e-EPOS controls automatically defaults and the machine will not function at full rated capacity.*

---

### IMPORTANT

---

**If the engine rpm is being manually adjusted, the equipment will not function in its optimum capacity. Please contact a DOOSAN distributor or service center for repairs.**

---

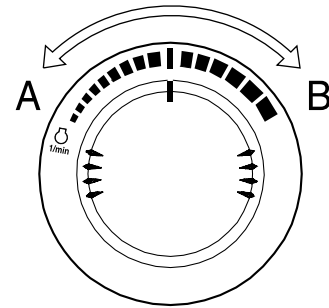

Figure 45

HAOA690L

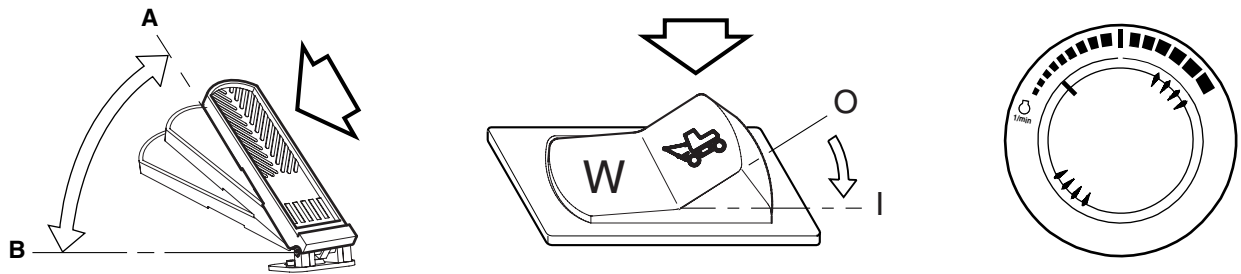

Figure 46

FG002663

Engine speed can be controlled by either the manual accelerator pedal or the manual speed control dial.

With the travel/work mode selector switch in the "TRAVEL MODE" position, all hydraulic controls are locked out. Full

engine speed range control is available through either the accelerator pedal or the manual engine speed control dial (A – B, Figure 46).

With the travel/work mode selector switch in the "WORK MODE" position, all hydraulic components are activated.

## Steering Wheel

The steering wheel allows the precise steering of the excavator.

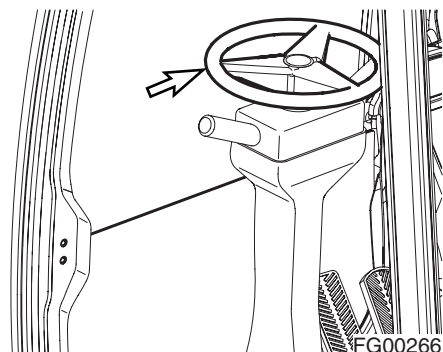

Figure 47

## Accelerator Pedal

The accelerator pedal controls the engine speed for traveling in the excavator.

The accelerator pedal functions in two ways. If the manual engine speed control dial is at the lowest setting, the accelerator pedal controls both engine speed and a hydraulic proportioning valve that controls the actual travel speed. If the manual engine speed control dial has been set to a higher rpm, the accelerator pedal functions only as a hydraulic proportioning valve control, enabling control of only travel speed and not engine rpm.

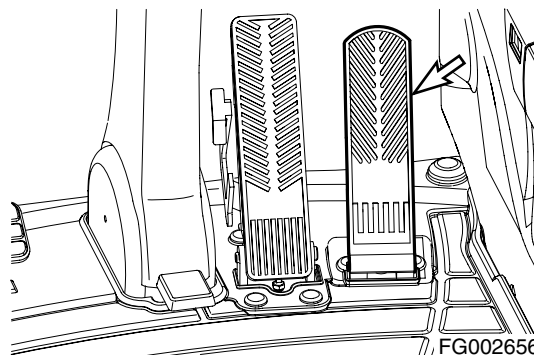

Figure 48

## Brake Pedal

The brake pedal operates the brake system. When the pedal(1, Figure 49) is pressed to its maximum position, it will lock into position. To release the brake pedal from the locked position, press down on the release pedal(2, Figure 49).

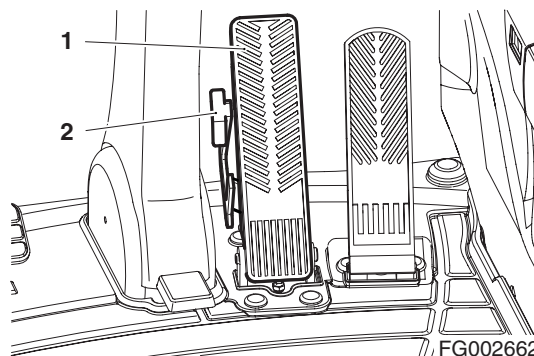

Figure 49

## Mode Selection

More efficient work can be done by choosing a proper power and work mode combination, suitable to type of work and conditions. Use the mode selection according to following guide.

### Power Mode

1. When the starter switch is turned "ON" the power mode is automatically defaulted to the standard setting.
2. Select a proper power mode using button (1, Figure 50) before starting work.
3. When the power mode button (1, Figure 50) is pressed, a signal sounds, changing the power mode to either "ON" or "OFF". When the power mode is turned "ON", the LED indicator (2, Figure 50) turns "ON".

Deactivate the power mode by pressing it a second time. When the power mode is turned "OFF", the LED indicator (2, Figure 50) turns "OFF" and the power mode returns to the standard mode.

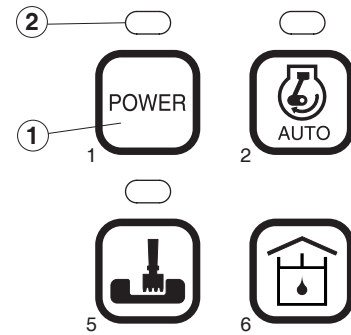

Figure 50

FG000114

Mode	Selection Point
STANDARD MODE	<ul style="list-style-type: none"> <li>• General work.</li> <li>• Normal speed travel.</li> <li>• Minimize fuel consumption.</li> </ul>
POWER MODE	<ul style="list-style-type: none"> <li>• Required to perform heavy work in a short period of time.</li> <li>• Fast speed loading.</li> <li>• Fast speed travel.</li> </ul>

### Work Mode

1. When the starter switch is turned "ON" the work mode is automatically defaulted to the digging mode.
2. Select the work mode using button (3, Figure 51) before starting work.
3. When the work mode button (3, Figure 51) is pressed, a signal sounds, changing the work mode to either "Digging Mode" or "Trenching Mode". When the trenching mode is selected, the LED indicator (4, Figure 51) turns "ON". When the digging mode is selected, the LED indicator (4, Figure 51) turns "OFF".
4. When the trenching mode is selected, the control valve is set to optimum condition for trenching work.

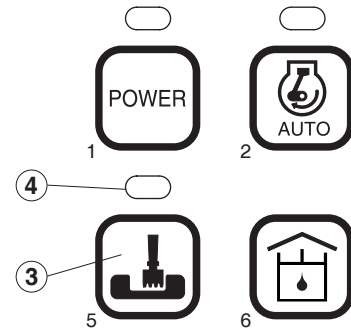

Figure 51

FG000115

Mode	Selection Point	Feature of Control
DIGGING MODE	<ul style="list-style-type: none"> <li>• General excavation.</li> <li>• Loading dump trucks.</li> <li>• Lifting and transport of heavy objects.</li> <li>• Breaker.</li> </ul>	General standard.

Mode	Selection Point	Feature of Control
TRENCHING MODE	<ul style="list-style-type: none"> <li>• Trenching.</li> <li>• Excavating of side wall.</li> <li>• Required to constant swinging.</li> </ul>	The swing is faster and stronger than boom or arm.

### Auto Idle Mode

1. The system will automatically reduce engine speed to idle speed approximately four seconds after all of the control levers are in the neutral position. When a pilot function is activated, engine speed is automatically returned to the preselected range.
2. When the starter switch is turned "ON", the work mode is automatically defaulted to "AUTO IDLE".
3. When the LED indicator (6, Figure 52) is turned "ON", the auto idle function is activated. Deactivate the auto idle function by again pressing the auto idle selector button (5, Figure 52). At this time the LED indicator will be turned "OFF".

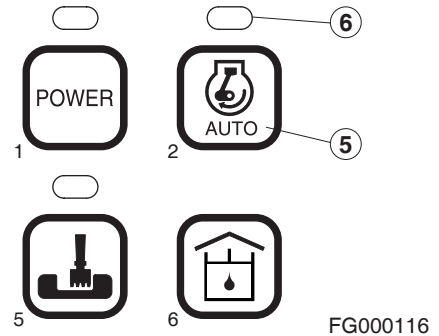

Figure 52

## WARNING!

Turn "OFF" auto idle function when performing work in close operating area, i.e., work in a narrow area and loading / unloading on or off a trailer.

### Boost Mode

1. Power boost switch is used to gain maximum digging force.
2. The power boost is activated while the lower button is being pressed on top of the right-hand work lever (joystick). The breaker / boost / shear selector switch must be in the "O" (BOOST) position.

**NOTE:** *The power boost mode does not affect forward and reverse travel.*

*Do not use this switch for more than ten seconds.*

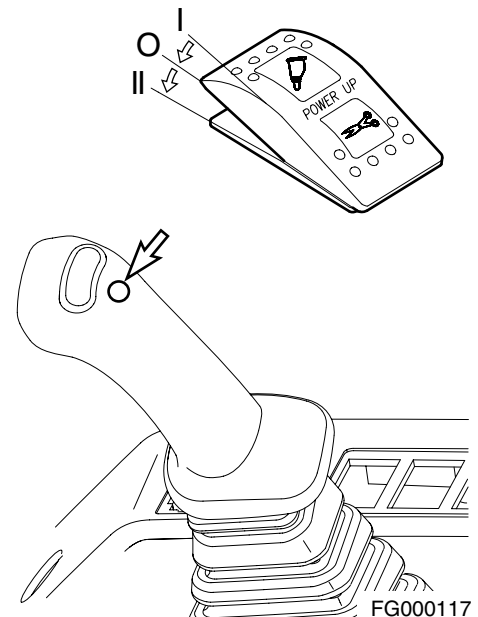

Figure 53 RIGHT-HAND WORK LEVER (JOYSTICK)

## Work Levers (Joysticks) (ISO Style)



### WARNING!

Check surrounding area before swinging. When operating a lever while in auto idle, do it carefully, because the engine speed will increase rapidly

**NOTE:** When starting work, move joysticks slowly and check movement of swing and front attachment and dozer (outrigger).

This equipment is manufactured using the lever configuration described in ISO standards. Do not change valving, hoses, etc., that would change this standard. The boom, arm and bucket movements, and swing direction of work levers (joysticks) are as follows:

#### Left-hand Work Lever (Joystick) (Figure 54 and Figure 56)

1. Arm dump
2. Arm crowd
3. Left swing
4. Right swing

**NOTE:** The swing brake is spring applied and hydraulically released. It is always engaged when the work lever (joystick) is in "NEUTRAL" or the engine is shut down.

**NOTE:** The following is not a mechanical malfunction but a proper phenomenon of the excavator. When operating the arm, it may stop momentarily. When the arm is operated, the weight of the arm may cause it to move faster than the amount of oil being supplied. In some cases while swinging or moving, the relief valves may make some noise. This is normal and does not affect the performance of the equipment.

#### Right-hand Work Lever (Joystick) (Figure 54 and Figure 56)

5. Boom down
6. Boom up
7. Bucket crowd
8. Bucket dump

**NOTE:** Even after stopping the engine, the front can be lowered to the ground by operating joystick. Set safety lever on "UNLOCK" position and turn starter switch "ON".

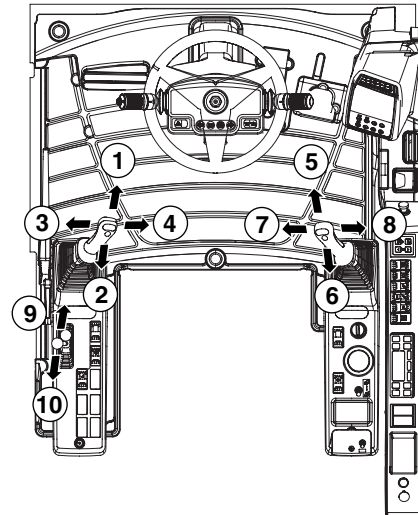

FG002664

Figure 54

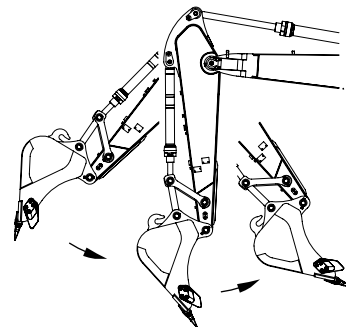

FG002669

Figure 55

## Dozer Blade and Outrigger Control Lever (Figure 54 and Figure 56)

9. Blade/Outrigger down
10. Blade/Outrigger up

The dozer blade control lever is on the left control stand. To lower blade, push lever forward; to raise blade, pull lever backwards.

Whenever dozer blade is being used to level ground, make sure to set travel speed control to "LOW SPEED" Attempting to use dozer blade in "HIGH SPEED" will cause damage to drive system.

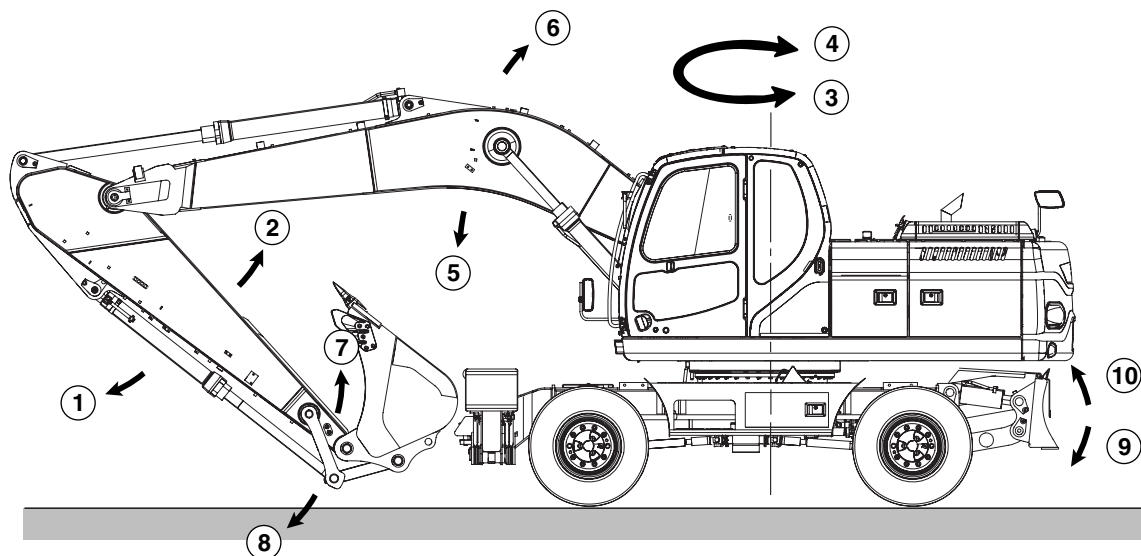

FG006563

Figure 56

Reference Number	Description
1	Arm Dump
2	Arm Crowd
3	Left Swing
4	Right Swing
5	Boom Down

Reference Number	Description
6	Boom Up
7	Bucket Crowd
8	Bucket Dump
9	Blade/Outrigger Down
10	Blade/Outrigger Up

### Independent Outriggers (Option)

If the machine is equipped with the optional independent outriggers.

Independent outriggers are operated with dozer control lever and select switches.

Select the outriggers with one or more of the switches, and then, push the lever forward to lower the outriggers, pull the lever backwards to raise the outriggers.

- 11. Outrigger down
- 12. Outrigger up

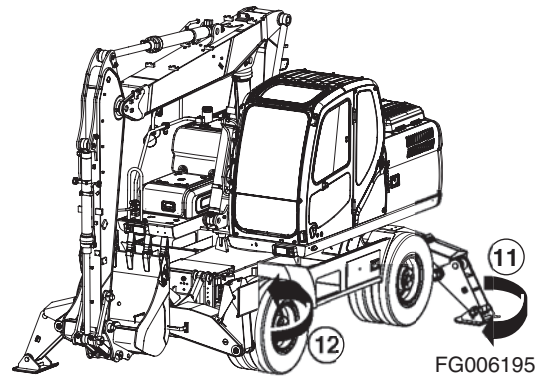

Figure 57

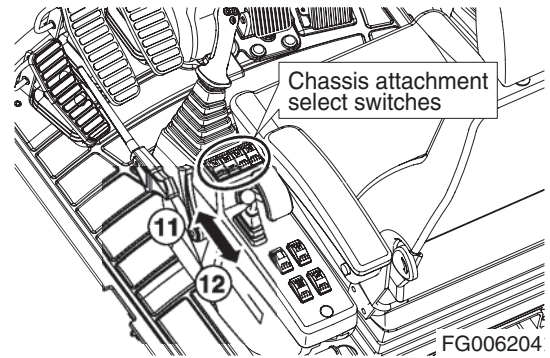

Figure 58

### Two-Piece Boom (Option)

- 13. Upper Boom Up
- 14. Upper Boom Down

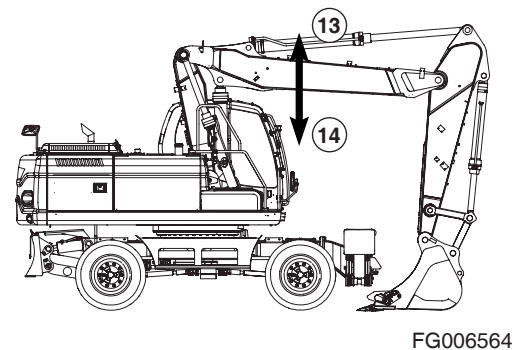

Figure 59

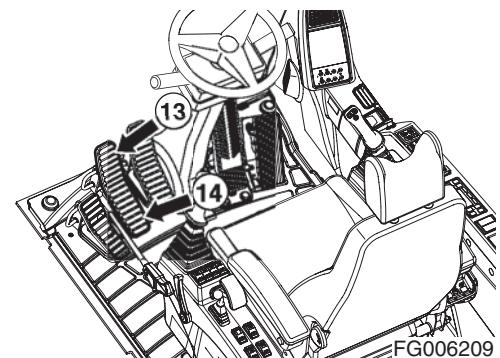

Figure 60

# OPERATING PRECAUTIONS

## WARNING!

Do not rest your feet on the travel pedals during normal machine operation. Unexpected machine travel may occur in this situation.

1. Before starting work, investigate terrain and soil condition. Level ground and drain area if necessary.
2. Install window guards when working where there is a possibility of falling rocks or other objects.

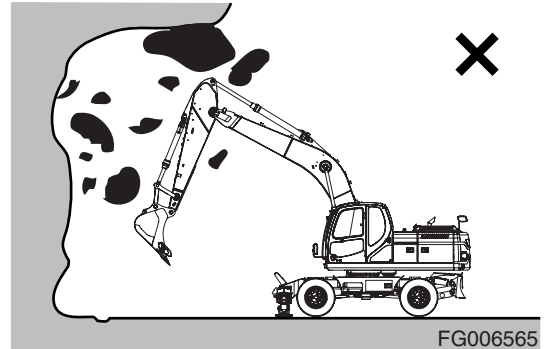

Figure 61

3. Check strength of supported structures in advance before working on them. If insufficient, reinforce it. If any doubt exists about structural strength, refuse to operate unit.
4. It is possible that the boom, arm or bucket may come into contact with the upper or lower structure of the machine (Especially tires). There are digging conditions which could allow this to happen.

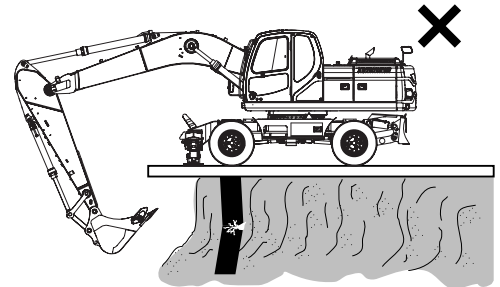

Figure 62

5. Never allow any person (material) etc. come within realm of equipment work range. Always mind surroundings when working and particularly take heed when in narrow place so that rear part would not be hit when turning.

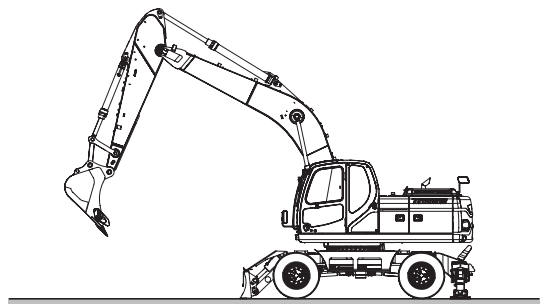
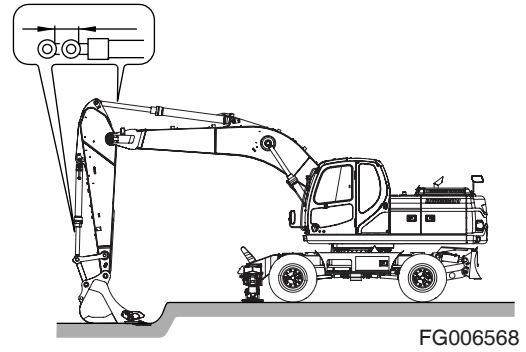

Figure 63

6. Do not continually "bottom out" the hydraulic cylinders. Machine damage may occur if the cylinders are fully extended or retracted, example: arm cylinder fully retracted and the bucket cylinder is extended to rotate the bucket into the ground.



**Figure 64**

7. Do not use machine travel or swing when the bucket is in the ground to provide additional breakout force. See Figure 65.

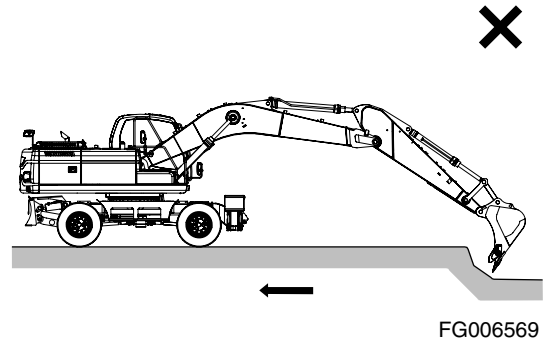

**Figure 65**

8. Do not use machine weight to provide additional breakout force. See Figure 66.
9. When working on soft or muddy ground, make sure that the machine is not sinking.

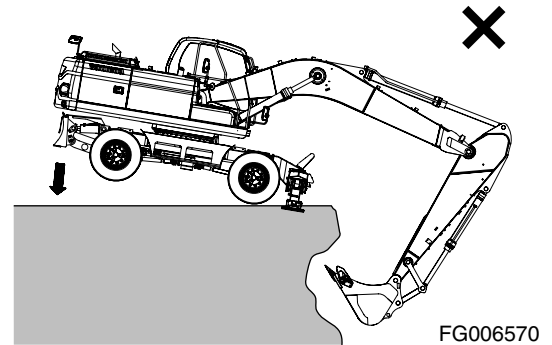

**Figure 66**

10. When working close to the excavated edge, make sure that the ground the machine is sitting on is solid.

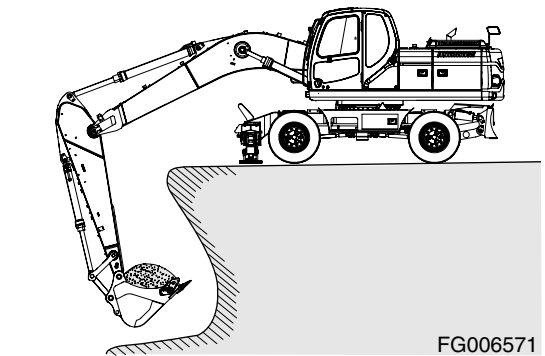

**Figure 67**

11. Do not excavate underneath the machine. See Figure 68.

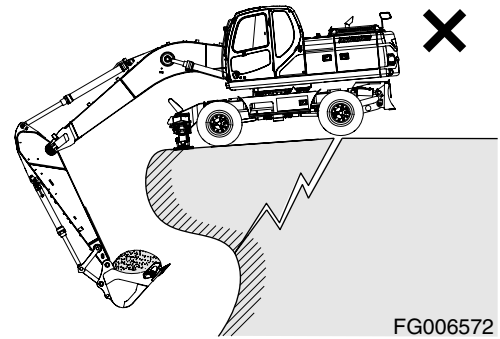

Figure 68

12. Make sure that there is adequate clearance from overhead electrical supply lines. See Figure 69.

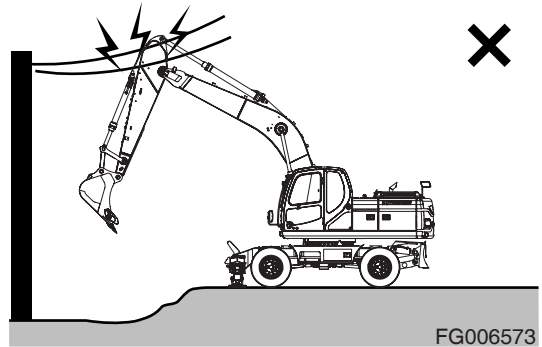

Figure 69

13. If the excavation is in an underground location or in a building, make sure that there is adequate overhead clearance and that there is adequate ventilation. See Figure 70.

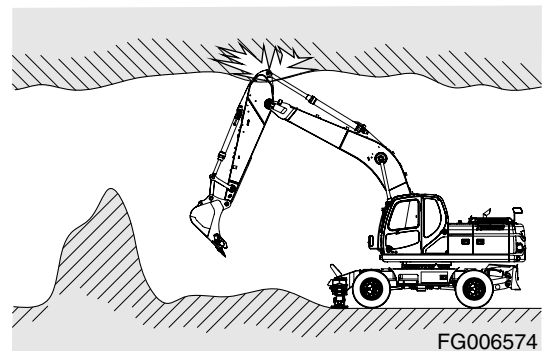

Figure 70

14. Do not use the bucket as a hammer or ramming device. This is dangerous and causes damage to the front attachment. See Figure 71.

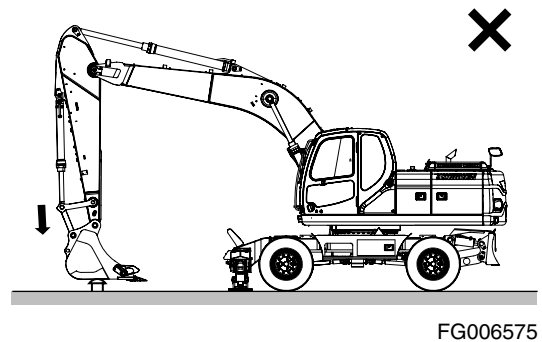
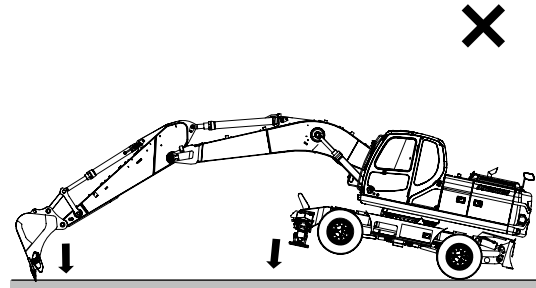

Figure 71

15. Do not dig with the excavator tires raised. This can result in structural and mechanical failures.
16. Do not operate travel lever quickly when traveling in high range.
  - Avoid sudden starts.
  - When traveling in one direction come to a complete stop before reversing directions. Do not rock excavator back and forth with levers.
  - Avoid sudden stops. Return levers to neutral by hand. Do not let them snap back to neutral on their own.
17. If the optional long fronts or attachments or heavy duty front end attachments are used, the machine balance will be altered. Follow these additional operating precautions.



FG006576

Figure 72

---

**! WARNING!**

**Do not travel downhill with the front end attachments raised.**

**Do not travel across slopes; travel straight up or down slope.**

**Use extreme caution when swinging the upper frame when positioned on a slope.**

**Allow extra swing stopping room. The additional momentum generated by the longer or heavier front end equipment will increase the amount of time needed to stop the swing motion.**

**Make sure that all optional equipment has been authorized and installed properly.**

18. Do not move dirt or objects by swinging the excavator into them. This can result in structural and mechanical failures.

---

**! DANGER!**

**When lifting the lower structure, place the round bottom of the bucket on the ground and place the arm and boom so that the angle between them are 90° ~ 110°.**

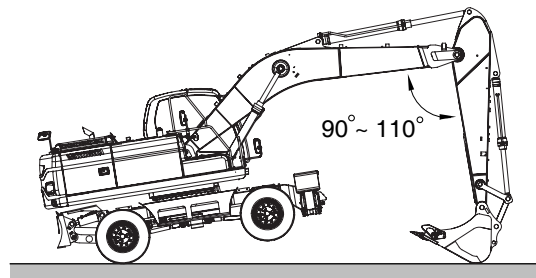

FG006577

Figure 73

## Working in Water

---

### IMPORTANT

---

When working in water, do not exceed a slope of more than 15°. If the slope is over 15°, the rear part of the upper structure will be immersed in water, resulting in radiator fan damage.

---

1. When working in water, do not operate in water over center of axle (1, Figure 75).

If swing bearing gets wet, immediately grease it until all old grease is purged from bearing.

If water gets into swing gear housing, drain water immediately by removing lower inspection cover. Apply new grease.

After working in water, purge old grease on bucket pins.

2. It is possible to work and travel in shallow water if the ground is stable. If the terrain is rough or if the water is flowing heavy it is unsafe to operate the equipment.
3. When working in wet soil, the equipment can sink into the soft ground. Select solid ground to secure the equipment before starting work.

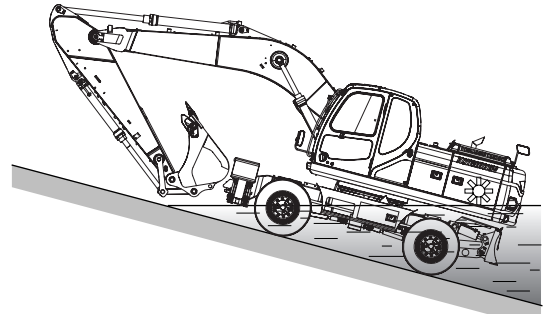

FG006578

Figure 74

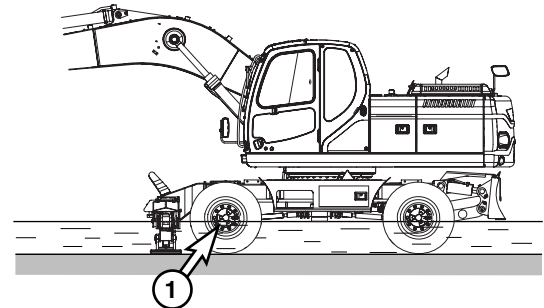

FG006579

Figure 75

# PARKING EXCAVATOR

## **WARNING!**

Park excavator on firm, level ground. Avoid parking on slopes. If excavator must be parked on a slope, block wheels (1) using the supplied wheel chocks (See "Wheel Chocks" on page 2-76.) and place bucket teeth in ground. (Figure 76)

1. Park excavator on firm, level ground. Lower bucket to ground as shown in Figure 77.

2. Set engine speed control dial on "LOW IDLE".

3. If you touch the operation lever unintentionally, it may create a serious accident. Before leaving operator's seat, set safety lever on "LOCK" position and raise left stand.

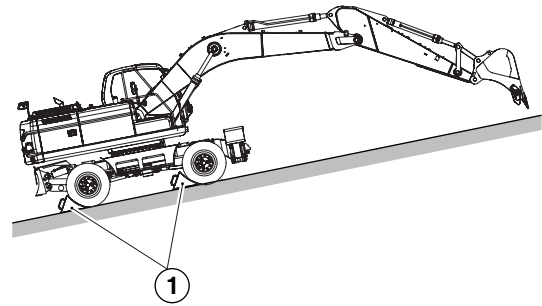

Figure 76

FG006580

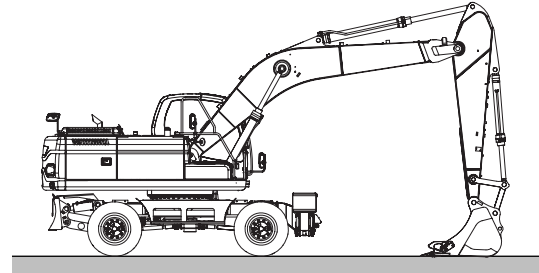

Figure 77

FG006581

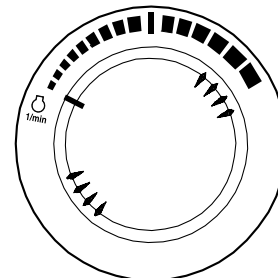

Figure 78

HAOB290L

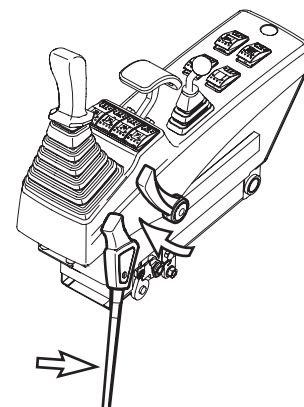

Figure 79

FG006173

# TOWING PROCEDURE

---



## WARNING!

---

Make sure that the towing vehicle can handle the weight of the unit being towed and that it has adequate braking capacity.

Never use a damaged wire rope or chain. They could brake and cause a serious accident.

Always wear gloves when handling a chain or wire rope.

When towing excavator use a wire rope or chain capable of handling the load.

---

## IMPORTANT

---

Parking brake automatically operates in case when engine is stop so that you shall release the parking brake into manual mode when towing equipment.

---

1. Fix equipment by wheel chock so that equipment would not move.
  2. Release the parking brake into manual mode.
  3. Mount wire rope at equipment.
  4. Remove chock and tow equipment
  5. Operate the parking brake again in manual mode after finishing towing.
- 



## CAUTION!

---

When towing equipment, towing speed shall be less than 10 km/h and movement distance shall be less than 5 km. Use trailer in equipment transference if moving over 5 km needs.

---

### How to release the parking brake (manual mode)

1. Set chock under tire so that vehicle would not move.
2. Grease at grease nipple (A) of transmission at rear side of facilities by means of grease gun. Whence grease amount shall be about 30 cc.
3. If grease leaks through relief valve (B), the parking brake release has been finished.



---

**Don't operate accelerator pedal when parking brake has been released manually.**

---

### How to let the parking brake operable again by dismissal of release condition (manual mode)

1. Open the bleeder (C) of transmission and make the equipment start.
2. Set engine at low speed racing, change gear from neutral to stage III, and wait until grease leaks. Whence wait time is about 1 min.
3. Completely exhaust grease from transmission by gear change between II ↔ III by some 5 ~ 10 reciprocations.
4. Lock bleeder (C).



---

**Take heed : grease will spout when initially opening bleeder.**

---

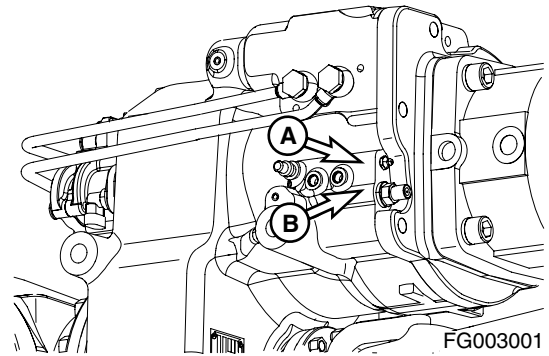

Figure 80

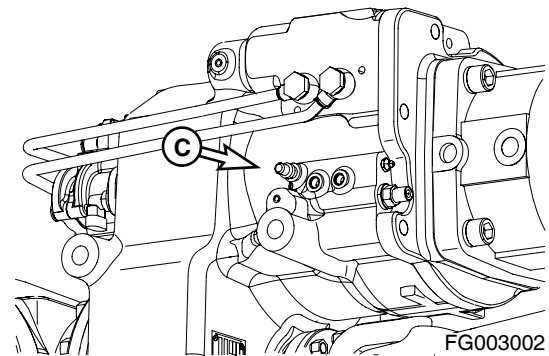

Figure 81

# HYDRAULIC BREAKER

---

## IMPORTANT

---

If a hydraulic breaker and piping is installed without *DOOSAN's* authorization, it may create a serious malfunction which will not be covered under the excavator warranty.

---

### Selection of Hydraulic Breaker

If a hydraulic breaker is installed, consider equipment's stability and suitability for such modification. Also, consider hydraulic oil pressure and quantity. When selecting a hydraulic breaker consult with a *DOOSAN* distributor or sales agency.

### Hydraulic Hoses and Tubing for Breaker

1. When installing hydraulic breaker, assemble according to drawings provided with kit.
2. If breaker is taken off excavator, be sure to plug and cap all hoses and tubing to prevent contamination from entering hydraulic system.
3. Plug and cap all connectors and fittings on breaker to prevent contamination.
4. Check all hydraulic connections for signs of leaks or loose components before starting operation.

### Hydraulic Breaker Operation

**NOTE:** *Hydraulic pressure and flow settings may need to be changed. Refer to the Maintenance Section of this manual for further information.*

1. Make sure to read and understand the breaker user's manual.
2. Inspect all mechanical and hydraulic connections.

3. Do not use the breaker as a hammer. (Figure 82.)

Do not drop breaker from extreme heights.

The breaker is relatively heavy and drops fast. Do not drop breaker from extreme heights or damage to upper structure may result

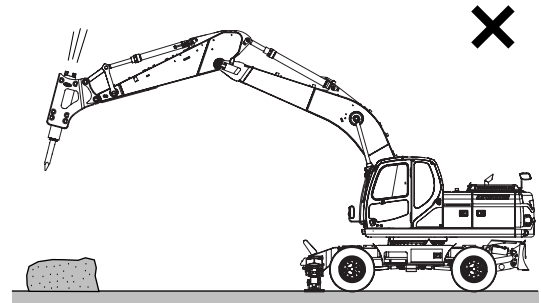

FG006582

Figure 82

4. Do not operate the breaker with the boom or arm cylinders fully extended (bottomed out). (Figure 83.)

Leave over 100 mm (4 in) of clearance between rod end of cylinder and cylinder head. This will help prevent damage to cylinders during breaker operation.

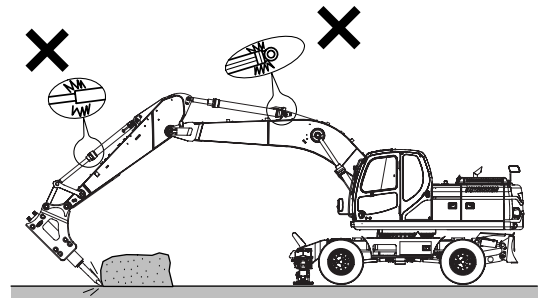

FG006583

Figure 83

5. Do not use the breaker if the hydraulic hoses vibrate excessively. (Figure 84.) Check the breaker's hydraulic accumulator for damage and repair as required. If excavator is operated under this condition, structural and hydraulic components can become damaged.

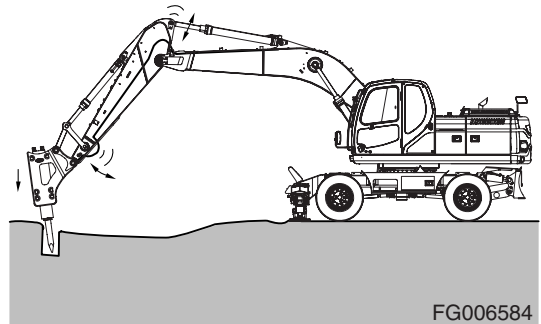

FG006584

Figure 84

6. Do not allow the breaker body to go into water if not equipped for underwater operation. The breaker seal can be damaged and allow rust, foreign material or water to enter the hydraulic system and cause damage. Only insert the breaker tool into water. (Figure 85.)

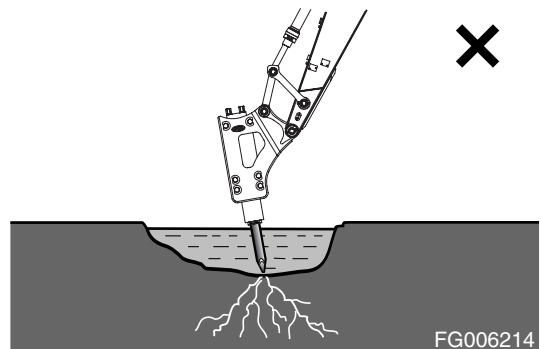

FG006214

Figure 85

7. Do not do any lifting or towing with a breaker. (Figure 86.)

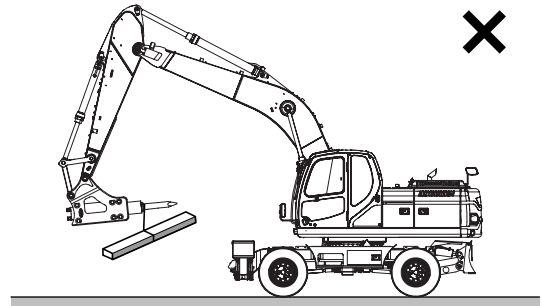

FG006585

Figure 86

8. Operate the breaker only to the front and rear of the excavator. Do not use the breaker to either side of the excavator. Do not swing the breaker from side to side when operating it. (Figure 87.)

---

 **WARNING!**

---

Operating a breaker with the upper body turned 90° to the chassis frame can result in tipping over the machine or reduction in service life.

---

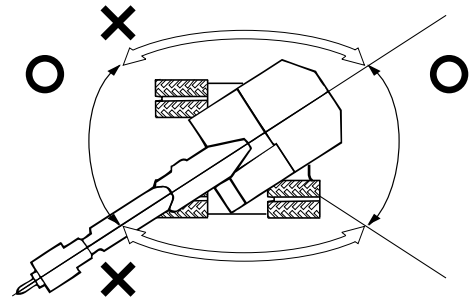

HGB3033L

Figure 87

9. Do not curl the breaker tool tip into the arm or boom when traveling or parking the excavator. (Figure 88.)

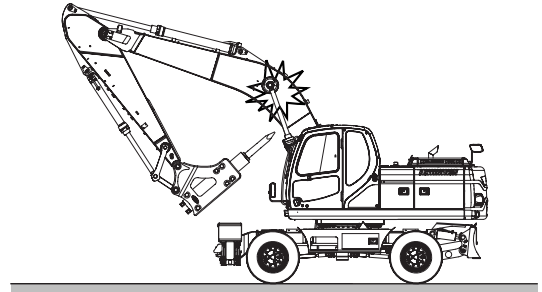

FG006588

Figure 88

### To activate breaker

1. Set breaker selector switch to "II" (BREAKER) position.
2. Press lower button on top of right-hand work lever (joystick) to activate hydraulic breaker.
3. Release lower button on top of right-hand work lever (joystick) to deactivate hydraulic breaker.

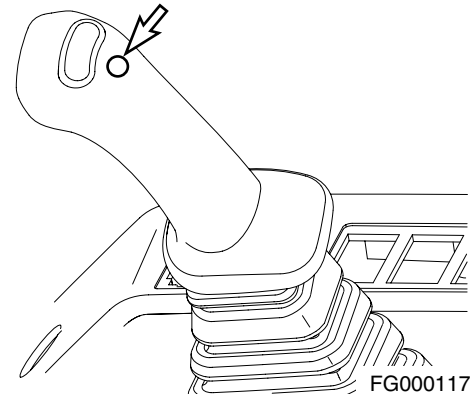
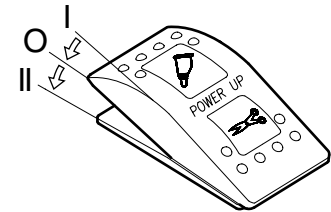

Figure 89 RIGHT-HAND WORK LEVER (JOYSTICK)

### Relief Valve Adjustment

1. Cap pipe on arm end, using a cap capable of handling 350.0 kg/cm<sup>2</sup> (5,000 psi) under the condition of disconnecting hose to hydraulic breaker.
2. Adjust pump pressure using activating the breaker, and watching the pressure displayed on the instrument panel. Press the display selector button to show digital pressure reading. (A separate pressure gauge is not required.)
3. Adjust the relief valve pressure by turning the adjustment screw of breaker relief valve. The relief valve is installed on the left side of the upper structure behind the boom. (Do not use the overload relief valve on the lower part of control valve for the breaker relief valve.)

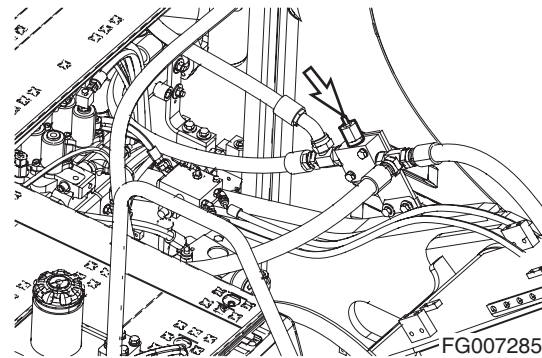

Figure 90



## WARNING!

If the relief valve pressure is adjusted while the hydraulic breaker is connected, there is possibility that a high-pressure spike or setting could break a hose or pipe. Personal injury or death could result from a hydraulic hose or pipe failure.

# Hydraulic Oil and Filter Service Intervals

When using a hydraulic breaker, the viscosity breakdown and contamination of hydraulic oil is faster because the work condition is more severe than during normal digging work. To prevent the hydraulic components (especially pump) from having a shortened life cycle, replace the hydraulic oil and main hydraulic oil return filter using the following schedule.

Attachment	Operation Rate	Hydraulic Oil	Filter
Bucket Work	100%	2,000 Hours	250 Hours (First Replacement) 1,000 Hours (After First Replacement)
Hydraulic Breaker Work	100%	500 Hours	100 Hours

\* These service intervals only apply, when a genuine DOOSAN oil and filter are used. If any other brands are used, the guaranteed changed interval should be reduced in half.

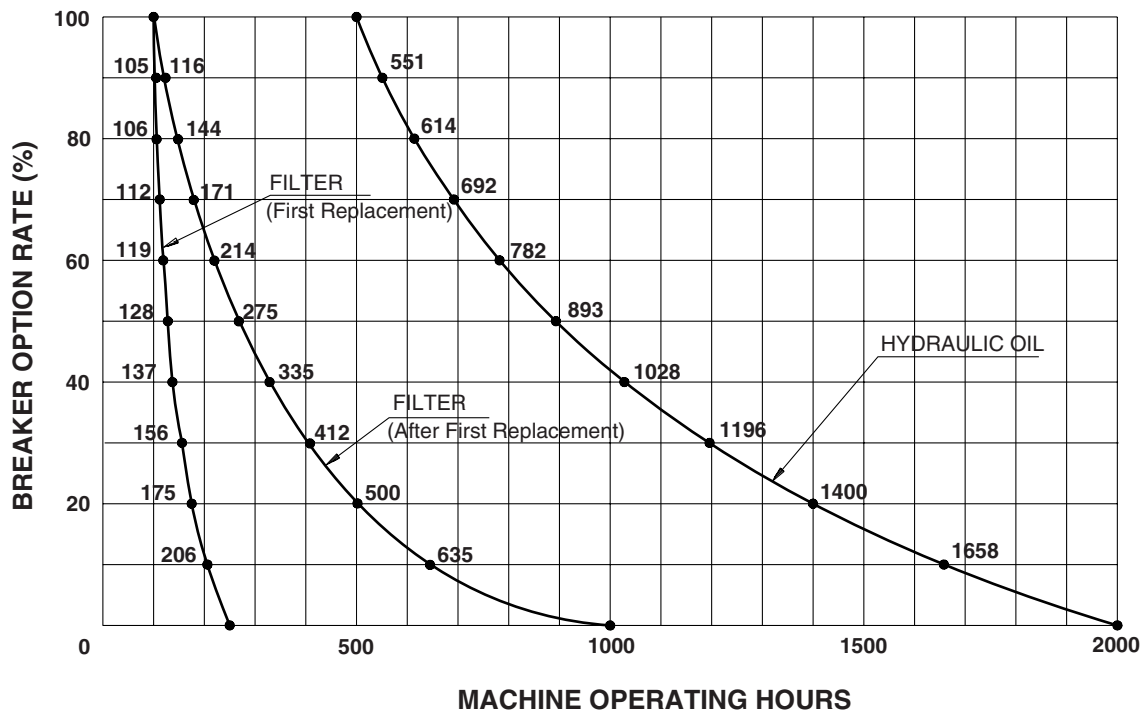

FG000767

Figure 91

**NOTE:** The replacement intervals of hydraulic oil and filter depend upon the amount of time the hydraulic breaker is being used. These intervals should be followed as opposed to regularly scheduled maintenance.

# ADJUSTING THE PUMP FLOW

**NOTE:** For further information, see "Flow Control" on page 2-49.

1. On the instrument panel, press the flow control button  , the flow control screen (Figure 92) will be displayed.
2. Use "UP" (▲) or "DOWN" (▼) buttons to adjust flow rate.
3. Press "SELECT" (◀) button, to return to normal display screen and save the flow rate setting.

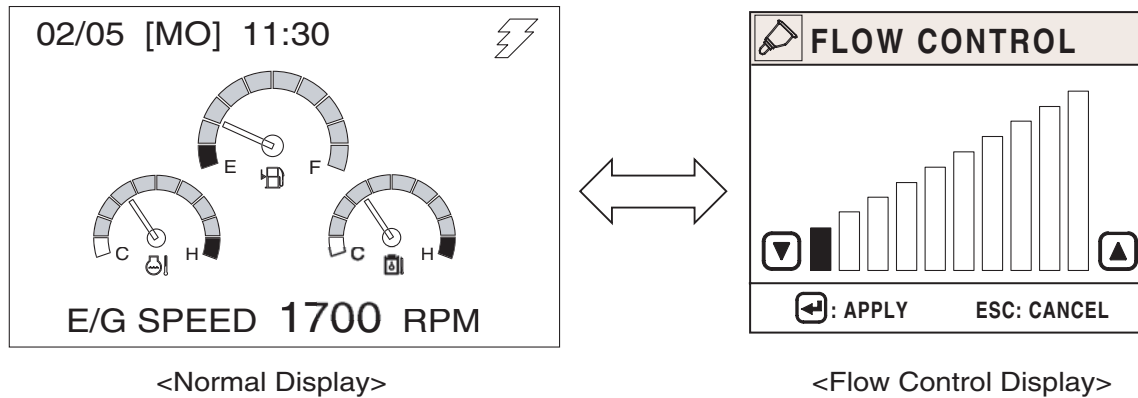

**Figure 92**

FG001090

Flow Control Step	Pump Flow Setting (l/min)
1	38
2	61
3	80
4	91
5	101
6	133
7	142
8	149
9	165
10	168

## Shear Pedal Valve (Optional)

### Activating Shear with Pedal Valve

1. Select shear with the selector switch of the right panel.
2. Two-way operation is possible by pressing the pedal back and forth between positions (1 and 2, Figure 93). When the pedal is in its center (at rest) position the valve is in "NEUTRAL" and hydraulic oil flow is stopped.
3. Before operating the attachment, be sure to check the function controlled by the direction of the pedal movement.

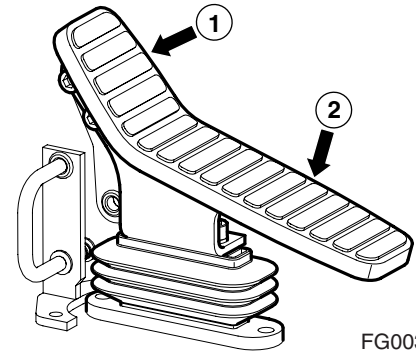

FG003010

Figure 93

### Activating Breaker with Pedal Valve

1. Select breaker with the selector switch of the right panel.
2. Pressing end (1, Figure 93) is used to activate the breaker.

### Locking the Pedal

When shear or breaker is not needed, the pedal can be locked by using the prop rod (3) locking device.

Locking is completed when the top end of the prop (3) is positioned into pedal hole.

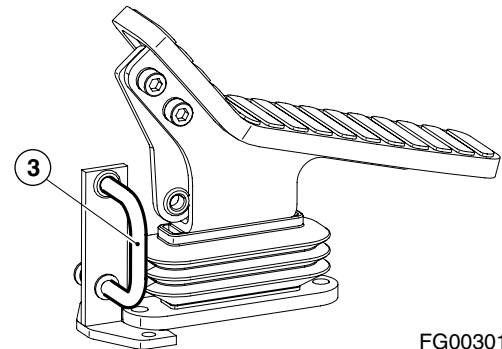

FG003011

Figure 94

- A. Location for "UNLOCKING".
- B. Location for "LOCKING".



## WARNING!

---

When operating breaker or shear when using button on a joystick, and it is not to be controlled by the pedal, be sure to keep the stopper in the "LOCK" position in order for the pedal not to be activated.

---

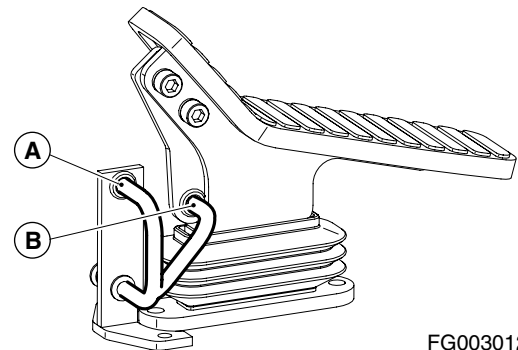

FG003012

Figure 95

# Rotating Pedal Valve (Optional)

## Attachment Rotating by Using the Pedal Valve

1. Pressing end (1, Figure 96) is used to turn front attachment (LH line high pressure).
2. Pressing end (2, Figure 96) is used to turn front attachment (RH line high pressure).

**NOTE:** Before activating the pedal, be sure to check the function of the attachment.

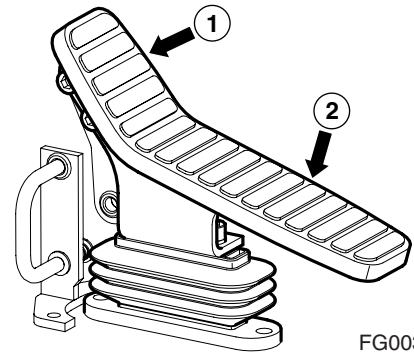

FG003010

Figure 96

## Locking the Pedal

When rotating is not needed, the pedal can be locked by using the prop rod (3) locking device.

Locking is completed when the top end of the prop (3) is positioned into pedal hole.

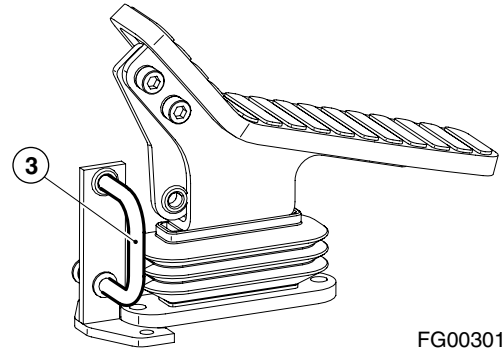

FG003011

Figure 97

- A. Location for "UNLOCKING".
- B. Location for "LOCKING".

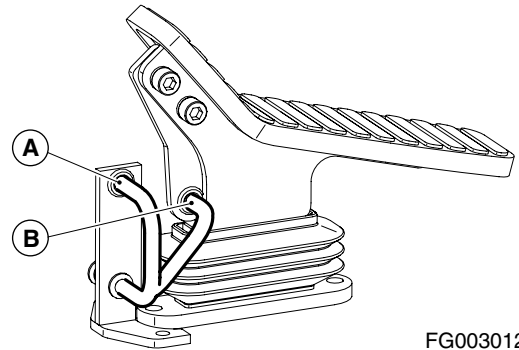

FG003012

Figure 98

## Attachment Rotation Using the Left-hand Work Lever (Joystick)

For a machine equipped with an attachment that rotates, rotation is activated while one of the control buttons is being pressed on top of the left-hand work lever (joystick).

There are three buttons on top of the left-hand work lever. The left and right ones are for controlling rotation.

**NOTE:** The middle button is for the horn.

Left button is for counterclockwise rotation, and the right one is for clockwise rotation.

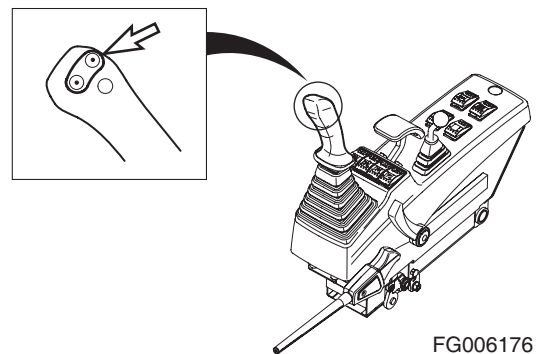

FG006176

Figure 99 LEFT-HAND WORK LEVER (JOYSTICK)

# OPERATING TECHNIQUES

## Lifting

---

### IMPORTANT

---

**There may be local or government regulations, about the use of excavators for the lifting of heavy loads. Always contact your local and government agencies in regards to these regulations.**

---

To prevent injury, do not exceed the rated load capacity of the machine. If the machine is not on level ground, load capacities will vary.

Short slings will prevent excessive load swing.

Use the lifting eye on the bucket that is provided to lift objects.

Always try to maintain the lifting eye (Figure 100) straight below the center line of the arm and bucket pin. In this manner the weight of the load is being primarily held only by the pin, and not by the bucket cylinder, link, and link pins.

When a lifting eye is used, the sling/lifting device must be fastened to the eye in a manner that will not allow it to come loose.

The most stable position is over the corner of the machine.

For best stability, carry a load as close to the ground and machine as possible.

Lift capacity decreases as the distance from the machine swing center line is increased.

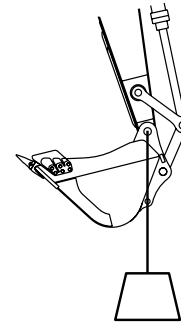

HAAD3830

Figure 100

### Lifting Unknown Weight

When loads are not accurately known are to be lifted, the person responsible for the job shall ascertain that the weight of the load does not exceed the machine LOAD RATING CHART at the radius at which it is to be lifted.

It is recommended that you feel your way into any lift as a precaution against tip-over. One method is to position the boom at 90° over the side of the machine. Slowly lift the load until it clears the ground. A lift over the side is the most unstable, and as the load is swung into the front zone of the excavator it will become more stable. **DO NOT INCREASE SWING RADIUS AFTER THE LOAD IS LIFTED.**

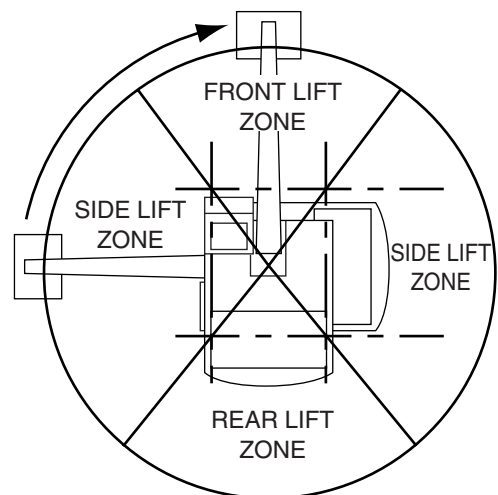

FG006217

Figure 101



## **DANGER!**

---

**If a load is picked up from the front zone and swung into the side zone, a tip-over could result causing a deadly or fatal injury.**

---

### **Lifting Known Weight**

The load chart is the governing factor when lifting known weights. It is recommended that you feel your way into any lift as a precaution against tip-over. Whenever possible, lift and swing payloads between the front idler area.

### **Pick and Carry**

The machine has the ability to pick and carry payloads without added labor. We recommend when traveling with a suspended payload, you evaluate the prevailing conditions and determine the safety precautions required in each case. The following factors must be considered before attempting to pick and carry a load.

Align the boom with the forward direction of machine travel. Maintain this boom position when turning the machine. Turn only when necessary, at the slowest speed, and at a wide turning radius.

1. Use the shortest lifting radius distance possible.
2. Keep the load as close to the ground as conditions will permit.
3. Provide tag lines to prevent load from pendulating. Pendulating can cause a change in radius. A change in radius could exceed the load chart rating or cause a tip-over condition.
4. Govern travel speed to suit conditions.
5. Avoid sudden starts and stops.

# OPERATION UNDER UNUSUAL CONDITIONS

**NOTE:** See "Maintenance in Special Conditions" on page 4-94 for other recommendations.

## Operation In Extreme Cold

If machine is to be operated in extreme cold weather temperatures, certain precautions must be taken to assure continued normal operation. The following paragraphs detail checks to be made to be certain the machine is capable of operating at these temperatures.

1. Check the cooling system for correct antifreeze solution for lowest temperature expected. Carefully inspect cooling system and correct or report any leaks.
2. Keep batteries fully charged to prevent freezing. If water is added to batteries, run engine at least one hour to mix electrolyte solution.
3. Keep engine in best possible mechanical condition to assure easy starting and good performance during adverse weather conditions.
4. Use engine oil of the proper specifications for the expected temperatures. Refer to the "Lubrication Specifications" of the engine manual for details.
5. Keep fuel tank full at all times. Drain condensation from tank before and after operation. Drain and service fuel filter. To eliminate clogging of fuel filters due to wax crystal formation in the fuel, be sure that the fuel used has a cloud point specification below the lowest expected temperature.
6. Lubricate entire machine according to "Periodic Service Table and Chart" Section 4, in this manual or lubrication chart on machine.
7. Start engine and allow it to reach normal operating temperature before applying load.
  - A. If mud and ice collects and freezes on any of the moving parts while machine is idle, apply heat to thaw the frozen material before attempting to operate machine.
  - B. Operate hydraulic units with care until they have reached a temperature to enable them to operate normally.
  - C. Check all machine controls and/or functions to be sure they are operating correctly.
8. An extra outer air filter should be kept in the operator's cabin to replace element that could become iced and cause restricted air flow to engine.

9. If cold weather starting aid must be used, see "Engine Starting" COLD WEATHER START portion of this manual.
10. Clean off all mud, snow and ice to prevent freezing. Cover machine with tarpaulin if possible, keep ends of tarpaulin from freezing to ground.

## Operation in Extreme Heat

Continuous operation of the machine in high temperatures may cause the machine to overheat. Monitor engine and transmission temperatures and stop machine for a cooling-off period whenever necessary.

1. Make frequent inspections and services of the fan and radiator. Check coolant level in radiator. Check grills and radiator fins for accumulation of dust, sand and insects which could block the cooling passages.
  - A. Formation of scale and rust in cooling system occurs more rapidly in extremely high temperatures. Change antifreeze each year to keep corrosion inhibitor at full strength.
  - B. If necessary, flush cooling system periodically to keep passage clear. Avoid use of water with a high alkali content which increases scale and rust formation.
2. Check level of battery electrolyte daily. Keep electrolyte above plates preventing damage to batteries. Use a slightly weaker electrolyte solution in hot climates. Dilute 1.28 specific gravity electrolyte as issued to 1.20 - 1.24 specific gravity readings at full charge. Recharge batteries whenever they reach a 1.16 specific gravity reading. Batteries self-discharge at a higher rate if left standing for long periods at high temperatures. If machine is to stand for several days, remove batteries and store in a cool place.



### **WARNING!**

---

**Do not store acid type storage batteries near stacks of tires; the acid fumes have a harmful affect on rubber.**

---

3. Service fuel system as directed in "Engine Fuel System" Section 5, of this manual. Check for water content before filling fuel tank. High temperatures and cooling off cause condensation in storage drums.
4. Lubricate as specified in "Periodic Service Chart and Table" Section 4, in this manual or Lubrication Decal on the machine.
5. Do not park machine in sun for long periods of time. When practical park machine under cover to protect it from sun, dirt and dust.

- A. Cover inactive machine with tarpaulin if no suitable shelter is available. Protect engine compartment, transmission and hydraulics from entrance of dust.
- B. In hot, damp, climates corrosive action will occur on all parts of the machine and will be accelerated during the rainy season. Rust and paint blisters will appear on metal surfaces and fungus growth on other surfaces.
- C. Protect all unfinished, exposed surfaces with a film of preservative lubricating oil. Protect cables and terminals with ignition insulation compound. Apply paint or suitable rust preventive to damaged surfaces to protect them from rust and corrosion.

## Operation in Dusty or Sandy Areas

Operation of the machine can cause dust in almost any area. However, when in predominantly dusty or sandy areas, additional precautions must be taken.

1. Keep cooling system fins and cooling areas clean. Blow out with compressed air, if possible, as often as necessary.



### **WARNING!**

---

**Wear goggles when using compressed air.**

---

2. Use care when servicing fuel system to prevent dust and sand from entering the tank.
3. Service the air cleaner at frequent intervals, check air restriction indicator daily and keep dust cup and dust valve clean. Prevent dust and sand from entering engine parts and compartments as much as possible.
4. Lubricate and perform services outlined on current lubrication chart on machine and "Lubrication Chart and Table" Section 4. Clean all lubrication fittings before applying lubricant. Sand mixed with lubricant becomes very abrasive and speeds wear on parts.
5. Protect machine from dust and sand as much as possible. Park machine under cover or protect with tarpaulin to keep dust and sand from damaging unit.

## Operation in Rainy or Humid Conditions

Operation under rainy conditions is similar to that as in extreme heat procedures listed previously.

1. Keep all exposed surfaces coated with preservative lubricating oil. Pay particular attention to damaged or unpainted surfaces. Cover all paint cracks and chip marks as soon as possible to prevent corrosive effects.

## Operation in Salt Water Areas

The corrosive effect of salt water and salt water spray is very extensive. When operating in salt water areas, observe the following precautions.

1. When exposed to salt water, dry machine thoroughly and rinse with fresh water as soon as possible.
2. Keep all exposed surfaces coated with preservative lubricating oil. Pay particular attention to damaged paint surfaces.
3. Keep all painted surfaces in good repair.
4. Lubricate machine as prescribed on lubrication chart on machine or "Periodic Service Table and Chart" Section 4, in this manual. Shorten lubricating intervals for parts subject to exposure to salt water, if found necessary.

## Operation at High Altitudes

Normally, operation of machine at high altitudes will be as outlined in extreme cold. Before operating at high altitudes, engine fuel and air mixture may have to be adjusted according to appropriate engine manual.

1. Check engine operating temperature for evidence of overheating. The pressure cap on radiator must make a perfect seal to maintain coolant pressure in the system.



# Inspection, Maintenance and Adjustment

## PREVENTIVE MAINTENANCE

Routine maintenance and inspections are required to keep your machine in the correct operating condition. The following pages list the inspection intervals, the system or component checks, and location references.

**NOTE:** *The following pages list the service checks and their required intervals. The service cycles may need to be shortened depending on the working conditions. Extremely hot or dusty conditions will require more frequent service. Operational hours are determined by the amount of time accumulated on the engine hour meter on the control console in the cabin.*

**NOTE:** *Besides the normal hour meter, the multifunction gauge can be used to keep track of the hours on individual filters. See “Filter / Oil Info” on page 2-44.*

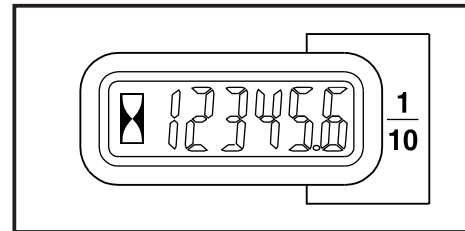

HAOA601L

Figure 1

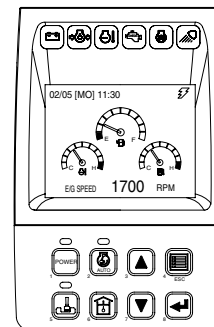

FG000037

Figure 2

## Product Identification Number (P. I. N.) Location

A P.I.N. number, is stamped on the upper frame, under the boom foot (Figure 3). It is also stamped on the product identification plate (Figure 4) on the front side of the battery frame on the outside.

**NOTE:** Please make note of these numbers and their locations. These will be required whenever warranty or service work is requested. Keep this number on file, incase the machine is stolen.

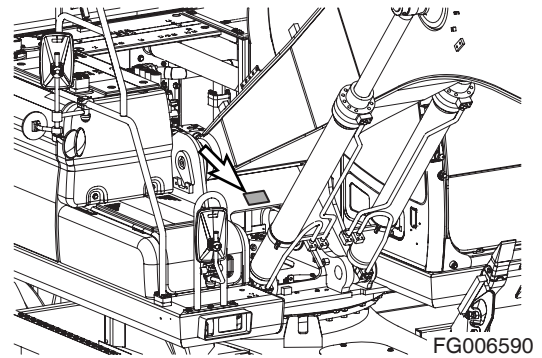
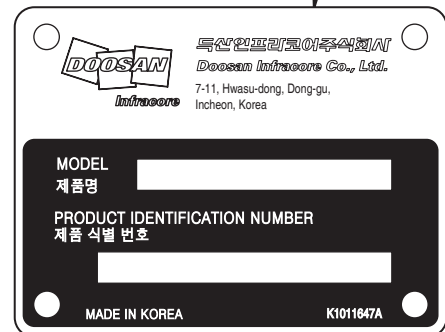
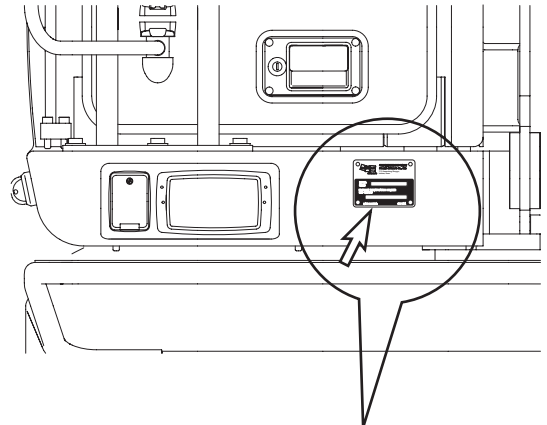

Figure 3



FG006329

Figure 4

## Component Serial Numbers

There are many serial numbers on each traceable components of the machine. For example, the engine serial number is stamped on the top of the engine block, above the starter. Additional engine information is described on a label (Figure 5) on the rocker cover.

Please make note of these numbers and their locations. These will be required whenever warranty service work is requested.

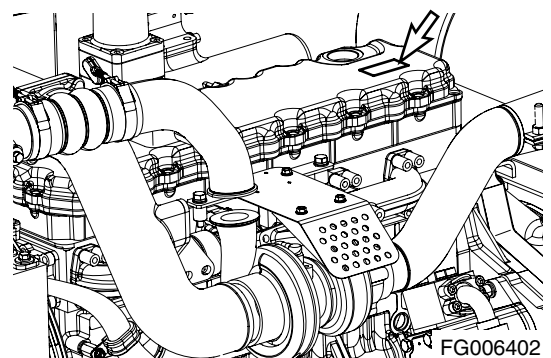

Figure 5

## **Safety Precautions**

1. Make sure to lock out the hydraulic controls and post a notice (Warning Tag) that the machine is being serviced to prevent any unauthorized operation.
2. Make sure to clean up any fluid spills, especially around the engine.
3. Inspect all fuel lines to make sure that fittings, lines, filters and O-rings, etc., are tight and are not showing signs of wear or damage.
4. If the inspection or test procedure requires that the engine be running, make sure to keep all unauthorized personnel away from the machine, and that all industry standard safety precautions are followed.

# PRELIMINARY WORK MACHINE SETUP FOR MAINTENANCE

When performing maintenance specified in this manual, always park the excavator as follows.

**NOTE:** *Certain types of maintenance may require the machine to be positioned differently. Always return machine to this position.*

1. Park on firm, level ground.
2. Lower bucket to ground.

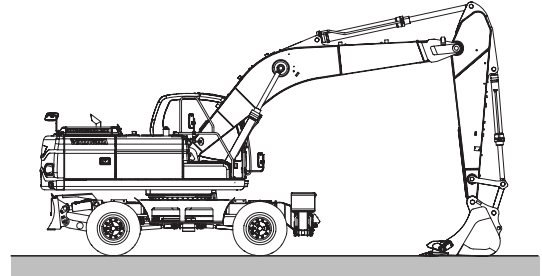

FG006589

Figure 6

3. Set safety lever on "LOCK" position and raise stand.

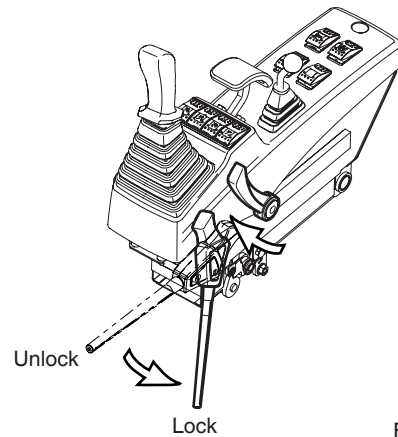

FG006403

Figure 7

4. Allow engine to run at low idle for a minimum of five minutes to allow engine to cool. If this is not done, heat surge may occur.

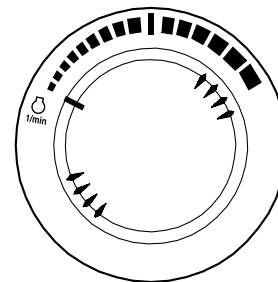

HAOB290L

Figure 8

5. Shut down engine by turning key to "O" (OFF) position. Remove key from starter switch.



## WARNING!

---

If engine must be run while performing maintenance, use extreme care. Always have one person in the cabin at all times. Never leave the cabin with the engine running.

---

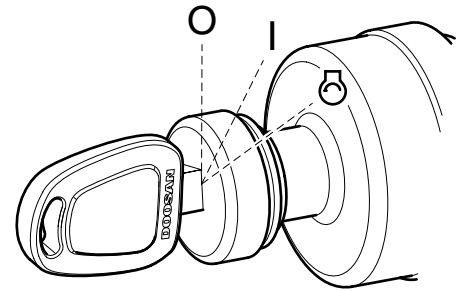

FG000175

Figure 9

6. Before starting maintenance work, hang up a tag, "Do Not Touch When Performing Inspection or Maintenance" on cabin door or work lever.

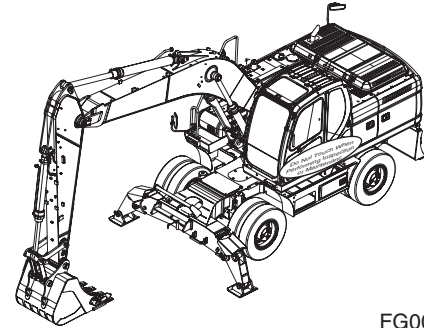

FG006591

Figure 10

# TABLE OF RECOMMENDED LUBRICANTS

**NOTE:** Refer to the Maintenance Intervals Table for application points.

Reservoir	Kind of Fluid	Ambient Temperature																	
		-22	-4	14	32	50	68	86	104	122									
		°F																	
									-30	-20	-10	0	10	20	30	40	50		
									°C										
Engine Oil Pan	** Engine Oil	SAE 10W-30																	
		* SAE 10W-40																	
		SAE 15W-40																	
Swing Drive Case	Gear Oil	SAE 90 and API GL5																	
		* SAE 80W-90 and API GL5																	
		SAE 140 and API GL5																	
Hydraulic Oil Tank	*** Hydraulic Oil	ISO VG 32																	
		* ISO VG 46																	
		ISO VG 68																	
Fuel Tank	Diesel Fuel	* ASTM D975 No. 2																	
		ASTM D975 No. 1																	
Grease Fitting	Grease	* Multipurpose Lithium Grease NLGI No. 2																	
Cooling System	Coolant	Add Antifreeze									* (50% antifreeze - 50% distilled water)								















# FLUID CAPACITIES

Component		Capacity
Engine	Oil Pan with Filter	25 liters (6.6 U.S. gal.)
	Cooling System	24 liters (6.3 U.S. gal.)
Fuel Tank		310 liters (81.9 U.S. gal.)
Hydraulic Oil	Tank Level	116 liters (30.6 U.S. gal.)
	System	205 liters (54.2 U.S. gal.)
Transmission		2.5 liters (0.66 U.S. gal.)
Swing Device		3.8 liters (1 U.S. gal.)
Axle	Front Differential	10.5 liters (2.8 U.S. gal.)
	Front Hub Reduction Gear	2 x 2.5 liters (2 x 0.66 U.S. gal.)
	Rear Differential	14 liters (3.7 U.S. gal.)
	Rear Hub Reduction Gear	2 x 2.5 liters (2 x 0.66 U.S. gal.)

## LUBRICATION AND SERVICE CHART

Lubrication and service chart is on the inside of battery box cover. The symbols shown here are used in the lubrication and service chart on the next page.

Symbol	Description
	Lubrication
	Gear Oil (Swing Device, Travel Device)
	Engine Oil
	Engine Oil Filter
	Hydraulic Oil
	Hydraulic Oil Return Filter

Symbol	Description
	Coolant
	Air Cleaner Element
	Fuel Filter
	Air Conditioner Filter
	Drain Water
	Gear Oil (Axle)

# Description of Lubrication and Service Chart

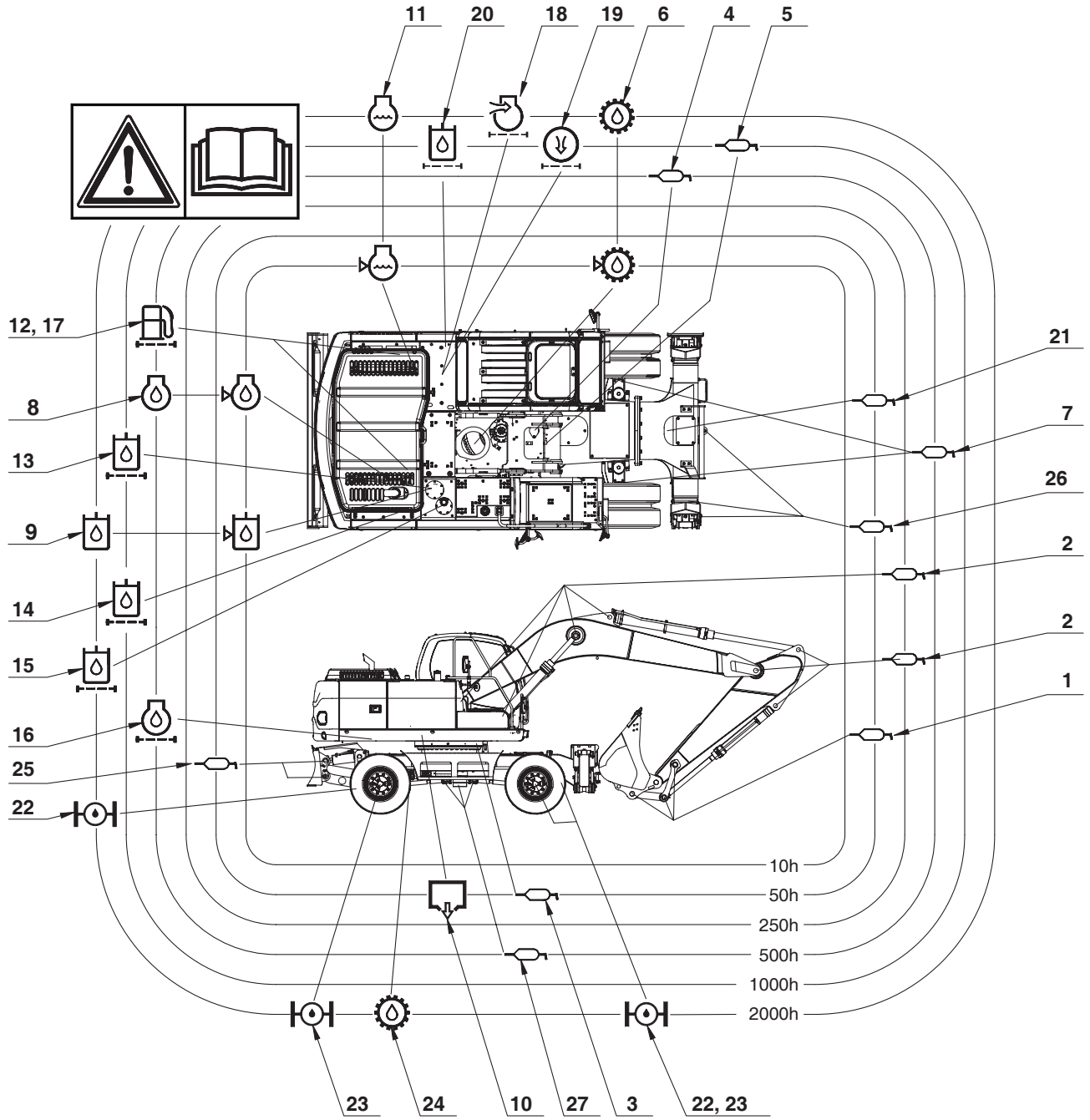

Figure 11

FG008698

SERVICE									
No.	Items to Check	Service	Qty.	DX210W					
				Service Interval					
				10	50	250	500	1000	2000
1	Front Joint Pin (1)	Grease	6	F100	W10				
2	Front Joint Pin (2)	Grease	11	F100		W10			
3	Swing Bearing	Grease	3						
4	Swing Gear and Pinion	Grease	1						
5	Swing Reduction Device	Grease	1						
6	Swing Reduction Device	Gear Oil (80W90)	3.8 L	V		F			
7	Front Axle Knuckle	Grease	4				W10		
8	Engine Oil	Engine Oil (RUBIA 7400)	25 L	V	F				
9	Hydraulic Oil	Hydraulic Oil	205 L	V					
10	Fuel Tank	Diesel	310 L	V					
11	Radiator	Coolant (Antifreeze)	24 L	V					PG
12	Fuel Prefilter	Cartridge	1	V					
13	Hydraulic Oil Return Filter	Element	1			F			
14	Pilot Filter	Element	1			F			
15	Hydraulic Oil Suction Strainer	Strainer	1						C
16	Engine Oil Filter	Cartridge	1						
17	Fuel Filter	Cartridge	1		F				
18	Air Cleaner (Outer)	Element	1				C		
	Air Cleaner (Inner)	Element	1						
19	Air Conditioner Filter (Outer)	Element	1				C		
	Air Conditioner Filter (Inner)	Element	1				C		
20	Brake Filter	Element	1			F			

**V:** Maintenance and Refill.

**C:** Cleaning.

**F:** First Time Exchange Only.

**F100:** Every 10 Hours For First 100 Hours.

**W10:** Every 10 Hours If Operating In Water.

**PG:** Propylene Glycol - Extended Life Antifreeze (Drain and replace using this interval.) See "Engine Cooling System" on page 4-79, for further explanation.

**█:** Replacement On Every Interval.

**NOTE:** For additional service items see list of "Maintenance Intervals" on page 4-12.

SERVICE DATA									
No.	Items to Check	Service	Qty.	DX210W					
				Service Interval					
				10	50	250	500	1000	2000
21	Front Axle Pin	Grease	2		W10				
22	Axle Case (Front)	Gear Oil (80w90)	10.5 L				F		
	Axle Case (Rear)	Gear Oil (80w90)	14 L				F		
23	Hub Reduction Gear Case	Gear Oil (80w90)	2 x 2.5 L				F		
	Hub Reduction Gear Case	Gear Oil (80w90)	2 x 2.5 L				F		
24	Transmission	Engine Oil (15w40)	2.5 L				F		
25	Dozer Blade Pin	Grease	12	F100	W10				
26	Outrigger Frame Pin	Grease	10	F100	W10				
27	Drive Shaft	Grease	8						
<b>V:</b> Maintenance and Refill.									
<b>C:</b> Cleaning.									
<b>F:</b> First Time Exchange Only.									
<b>F100:</b> Every 10 Hours For First 100 Hours.									
<b>W10:</b> Every 10 Hours If Operating In Water.									
█: Replacement On Every Interval.									
<b>NOTE:</b> For additional service items see list of "Maintenance Intervals" on page 4-12.									

# MAINTENANCE INTERVALS

SERVICE ITEM	PAGE
<b>10 Hour / Daily Service</b>	
Inspect All Tires for Correct Tire Pressure and Signs of Damage or Abnormal Wear	4-15
Grease Dozer Blade Pins	4-15
Grease Outrigger Pins	4-15
Grease Boom, Arm and Front Attachment Pins (for first 100 hours)	4-15
Check Engine Oil Level	4-16
Check Level of Hydraulic Oil Tank	4-16
Check for Leaks in Hydraulic System	4-18
Check Fuel Level	4-18
Check for Leaks in Fuel System	4-19
Check Fuel Prefilter and Drain Water As Required	4-19
Check Oil Level of Swing Reduction Device	4-19
Clean Dust Net in Front of Oil Cooler and Intercooler	4-21
Check Cooling System and Refill as Required	4-21
Check Level of Window Washer Liquid	4-22
Inspect Bucket Teeth and Side Cutters for Signs of Wear	4-22
Inspect Cooling Fan Blade	4-22
Check Air Intake System	4-23
Inspect Seat Belt for Proper Operation	4-23
Inspect Structure for Cracks and Faulty Welds	4-23
Check Operation of All Switches	4-23
Check Operation of All Exterior Lights, Horn and Control Console Indicator and Monitor Lights	4-24
Start Engine, Check Starting Ability, and Observe Exhaust Color at Start-up and at Normal Operating Temperature. Listen for Any Abnormal Sounds	4-24
Check Operation of All Controls	4-24
<b>50 Hour / Weekly Service</b>	
Perform All 10 Hour / Daily Service Checks	4-25
Grease Boom, Arm and Front Attachment Pins	4-25
Grease Swing Bearing	4-26
Grease Dozer Blade Pin	4-27
Grease Outrigger Pins	4-27
Grease Front Axle Pin	4-28
Drain Water and Sediment from Fuel Tank	4-28
Check Engine Fan Belt for Cracks, Wear and Correct Tension (After First 50 Hours)	4-28
Change Engine Oil and Filter (After First 50 Hours)	4-28
Inspect for Any Loose or Missing Nuts and Bolts	4-28
<b>250 Hour Service</b>	
Perform All 10 Hour / Daily and 50 Hour Service Checks	4-29
Grease Arm and Front Attachment Pins	4-29

<b>SERVICE ITEM</b>	<b>PAGE</b>
Check Engine Fan Belt for Cracks, Wear and Correct Tension	4-31
Check Engine Fan Belt Wear	4-32
Change Breaker Filter Element (Optional)	4-33
Change Swing Reduction Device Oil (Drain and Refill After First 250 Hours)	4-33
Replace Full Flow Hydraulic Oil Filter (After First 250 Hours)	4-33
Change Pilot Filter (After First 250 Hours)	4-33
Change Brake Filter (After First 250 Hours)	4-34
Inspect Pins and Bushings of Front End Attachments for Signs of Wear	4-34
Check Fluid Levels in Batteries and Battery Charge Levels	4-34
Inspect for Any Loose or Missing Nuts and Bolts	4-34
Inspect Fuel System Hose Clamps	4-34
<b>500 Hour / 3 Month Service</b>	
Perform All Daily, 50 and 250 Operating Hour Service Checks	4-35
Grease Swing Gear and Pinion	4-35
Change Engine Oil and Filter	4-36
Clean Air-Conditioning Outer Filter	4-37
Check and Clean Air-Conditioning Inner Filter	4-38
Clean Radiator, Oil Cooler, Intercooler, Fuel Cooler and Air Conditioner Condenser Core	4-39
Grease Drive Shaft	4-40
Grease Front Axle Steering Knuckle (2 X 2 points, 4 points)	4-41
Clean Outer Filter of Air Cleaner	4-41
Change of Fuel Prefilter	4-43
Change Fuel Filter	4-44
Drain and Refill Transmission Fluid	4-45
Drain and Refill Hub Reduction Gear Oil	4-45
Drain and Refill Front Axle Case Oil	4-45
Drain and Refill Rear Axle Case Oil	4-45
<b>1,000 Hour / 6 Month service</b>	
Perform All Daily, 50, 250 and 500 Operating Hour Service Checks	4-46
Grease Swing Reduction Device	4-46
Change Pilot Filter	4-48
Change Brake Filter	4-49
Change Air-Conditioning Outer Filter	4-50
Check Air Conditioner Refrigerant	4-51
Check and Adjust Engine **	4-52
<b>2,000 Hour / Yearly Service</b>	
Perform All Daily, 50, 250, 500 and 1,000 Hour Service Checks	4-53
Change Swing Reduction Device Oil	4-53
Replace Outer and Inner Air Cleaner Elements	4-54
Change Radiator Coolant	4-55
Hydraulic Oil Exchange and Suction Strainer Cleaning	4-56

<b>SERVICE ITEM</b>	<b>PAGE</b>
Drain and Refill Transmission Fluid	4-58
Drain and Refill Front Axle Case Oil	4-58
Drain and Refill Rear Axle Case Oil	4-59
Drain and Refill Hub Reduction Gear Oil	4-59
Check Alternator and Starter**	4-60
Check All Rubber Antivibration Shock Mounts	4-60
Perform and Record the Results of the Cycle Time Tests	4-60
Inspect Machine to Check for Cracked or Broken Welds or other Structural Damage	4-60
Check, Adjust Valve Clearance **	4-60
Check Head Bolt Torques	4-60
<b>4,000 Hour / Biennial Service</b>	
Major Parts - Periodic Replacement	4-61
<b>12,000 HOUR / SIX YEAR SERVICE</b>	
Hose In-service Lifetime Limit (European Standard ISO 8331 and EN982 CEN)	4-62

\*\* These checks need to be completed by an authorized *DOOSAN* dealer.

# 10 HOUR / DAILY SERVICE

## Inspect All Tires for Correct Tire Pressure and Signs of Damage or Abnormal Wear

1. Inflate tires to proper operating pressure for working conditions. See "Tire Changing Procedure" on page 4-87.

## Grease Dozer Blade Pins

1. Grease every 10 hours for first 100 hours and every 50 hours thereafter. (See page 4-27)

**NOTE:** *If the unit has been running or working in water the blade should be greased daily or every 10 hours.*

## Grease Outrigger Pins

1. Grease every 10 hours for first 100 hours and every 50 hours thereafter. (See page 4-27)

**NOTE:** *If the unit has been running or working in water the outrigger should be greased daily or every 10 hours.*

## Grease Boom, Arm and Front Attachment Pins (for first 100 hours)



### **WARNING!**

---

Do not remove the grease fitting until the pressure is entirely bleed off by loosening grease fitting slowly to avoid fatal wound.

Let anybody never be in the blowing direction.

Be careful to any kinds of works for nipples and hydraulic line plugs.

---

Grease every 10 hours for first 100 hours and every 50 or 250 hours thereafter (See page 4-25).

**NOTE:** *If the unit has been running or working in water the front attachment should be greased on a 10 hour / daily basis.*

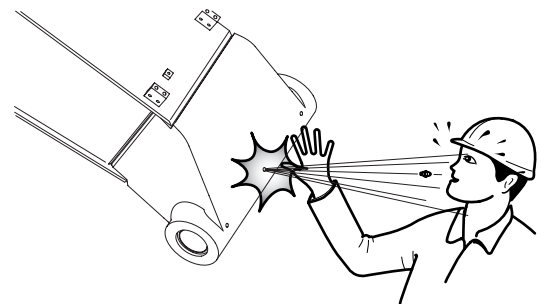

FG000500

Figure 12

## Check Engine Oil Level



### WARNING!

Allow the engine to cool before checking the oil level to avoid burns by touching hot engine parts.

**NOTE:** When checking level using a dipstick always remove and wipe it clean before making final level check.

1. Shut down engine and wait for 15 minutes. This will allow all oil to drain back to oil pan.
2. Remove dipstick (1, Figure 13) and wipe the oil off with a clean cloth.
3. Insert dipstick fully in the oil gauge tube, then take it out again.
4. Engine oil level must be between "HIGH" and "LOW" marks on dipstick.

**NOTE:** If oil is above "HIGH" mark on dipstick, some must be drained to return oil to proper level.

5. Add oil through engine oil fill cap (2, Figure 13), if the oil level is below the "LOW" mark.

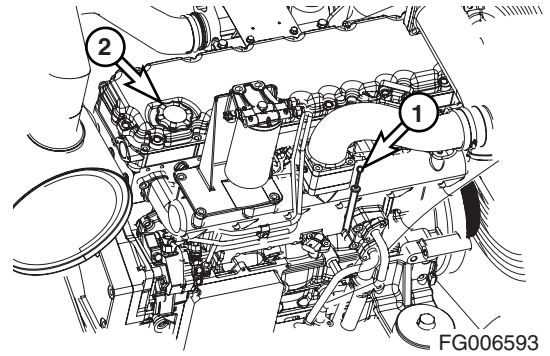
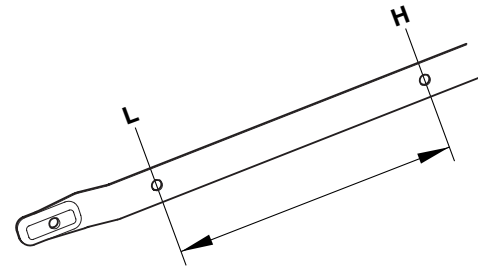

Figure 13



FG006334

Figure 14

## Check Level of Hydraulic Oil Tank



### WARNING!

The hydraulic oil will be hot after normal machine operation. Allow the system to cool before attempting to service any of the hydraulic components.

The hydraulic tank is pressurized. Turn the breather cap to allow pressurized air to vent. After pressure has been released, it is safe to remove either the breather cap or service covers.



ARO1760L

Figure 15

1. Position the machine on firm, level ground. Lower boom and position bucket on ground as shown in Figure 16.
2. Set engine speed to "LOW IDLE."

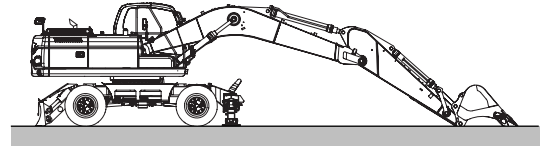

FG006594

Figure 16

3. Set safety lever to and stand "LOCK" position.
4. Check level gauge by opening right access door. Oil level must be between marks on sight gauge.

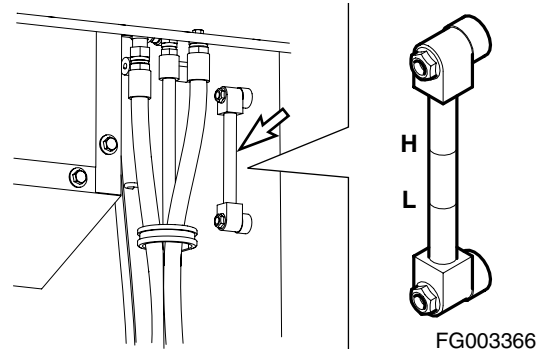

FG003366

Figure 17

5. If the level is below "L" mark add oil.
  - A. Shut down engine.
  - B. The hydraulic tank is pressurized. Turn the breather cap slowly to allow the pressurized air to vent.
  - C. Remove upper cover hydraulic tank and add oil.

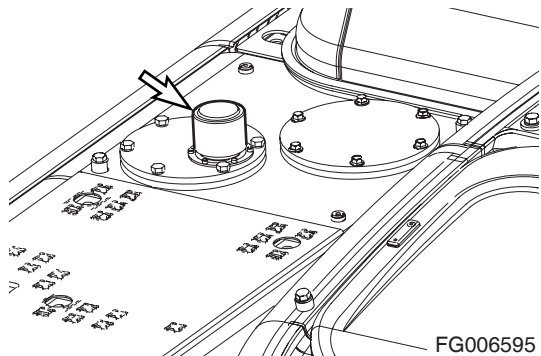

FG006595

Figure 18

## IMPORTANT

**Do not fill above "H" mark on sight gauge. Overfilling can result in damage to equipment and oil leaking from hydraulic tank due to expansion.**

6. If oil level is above the "H" mark drain oil.
  - A. Shut down engine and wait for the hydraulic oil to cool down.
  - B. Drain the excess oil from drain valve (Figure 19) at the bottom of tank into a suitable container, using a hose connected to the valve.

**NOTE:** *Dispose of drained fluids according to local regulations.*

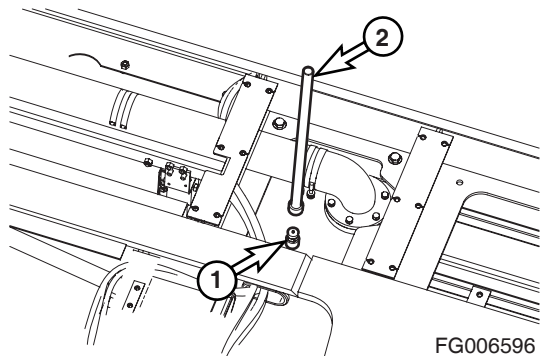

FG006596

Figure 19

## Check for Leaks in Hydraulic System

1. Perform a daily walk-around inspection to make sure that the hoses, piping, fittings, cylinders and hydraulic motors are not showing any signs of leakage. If any is noted, determine the source of the leak and repair.

## Check Fuel Level



Use extreme safety precautions while refueling to prevent explosions or fire.

Immediately clean up any spilled fuel.

---

1. At end of each work day, fill fuel tank. Add fuel through fuel fill tube (1, Figure 20). When working at a temperature of 0°C (32°F) or higher, use ASTM No. 2-D or its equivalent. At temperatures below 0°C (32°F) use ASTM No. 1-D or its equivalent.
2. Make sure that the fuel fill hose is grounded to the excavator before fueling begins.
3. Check the amount of fuel in the tank by observing the fuel tank sight gauge (2, Figure 20) and fuel gauge in monitor panel. Fill the tank using the fill tube with the proper fuel for the operating conditions.

**NOTE:** See "Fluid Capacities" on page 4-8. for capacity.

4. The excavator may be equipped with the optional battery operated fuel fill pump. The pump assembly is located in the battery box. Put the suction hose of the pump into the fuel resupply tank. Turn the switch in the battery box "ON," and the fuel will be pumped into the excavator fuel tank.
5. Do not overfill the tank.
6. Securely tighten cap after fueling.

**NOTE:** If breather holes in cap are clogged, a vacuum may form in the tank preventing proper fuel flow to engine. Keep holes in fuel cap clean.

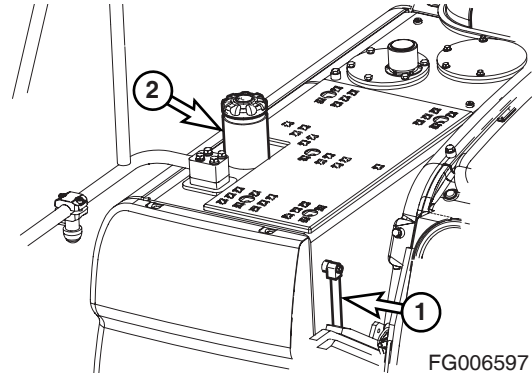

Figure 20

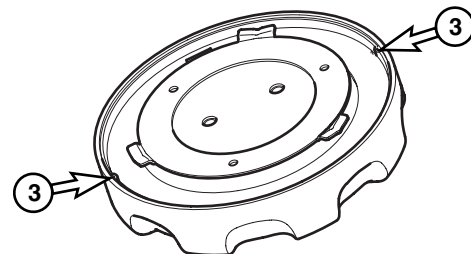

Figure 21

FG000317

## Check for Leaks in Fuel System

1. Perform an inspection of the engine compartment to verify that the fuel system is not leaking. If any is noted, determine the source of the leak and repair.

## Check Fuel Prefilter and Drain Water As Required

1. A fuel prefilter is inside the left side access door.
2. Open the access door on left side of the machine.

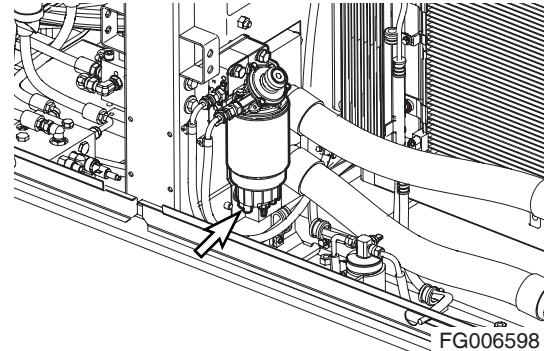

Figure 22

3. It is necessary to drain the collected water if the bowl is full of water or sediment.
4. Position a small container under fuel prefilter. Drain water or sediment by opening drain valve (2, Figure 23) on bottom of bowl (1).

**NOTE:** *Dispose of drained fluids according to local regulations.*

5. Close drain valve.

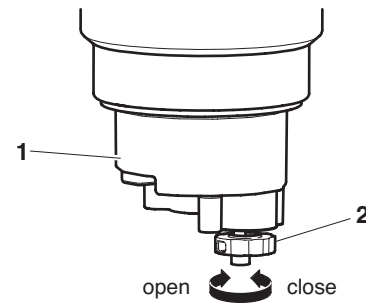

Figure 23

## Check Oil Level of Swing Reduction Device



---

The gear oil is very hot after the machine has been operating. Shut all systems down and allow them to cool. Before fully removing any motor case inspection port plug, etc., loosen the plug slightly to allow pressurized air to escape.

---

**NOTE:** *When checking level using a dipstick always remove and wipe it clean before making final level check.*

1. Remove dipstick (1, Figure 24) and wipe the oil from the dipstick with a cloth.
2. Insert dipstick (1, Figure 24) fully into dipstick tube.

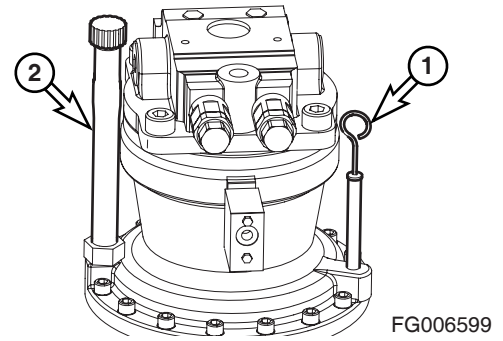
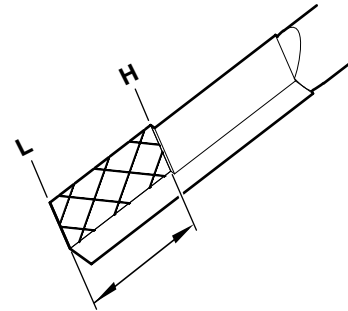

Figure 24

3. When dipstick is pulled out, oil level must be between "HIGH" and "LOW" marks on dipstick.

**NOTE:** *If oil is above "HIGH" mark on dipstick, some must be drained to proper level.*

4. If the oil does not reach the "L" mark on the dipstick, add oil through fill port (2, Figure 24).



FG000419

Figure 25

5. If the oil level exceeds the "H" mark on the dipstick, open cap (3, Figure 26) of drain valve and connect hose (4) to the valve. Drain the excessive oil into a suitable container.

**NOTE:** *Dispose of drained fluids according to local regulations.*

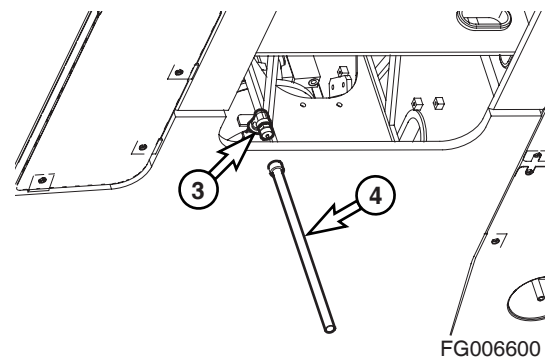

FG006600

Figure 26

## Clean Dust Net in Front of Oil Cooler and Intercooler

---

### IMPORTANT

---

If running excavator in dusty area, check dust net everyday and clean it if dirty.

---

### WARNING!

---

If using compressed air or water to clean the dust net, make sure that proper eye protection is worn.

---

1. Loosen the wing nut(s) and remove dust net.
2. Clean with compressed air or water.

## Check Cooling System and Refill as Required

---

### WARNING!

---

Allow the engine to cool before releasing the radiator cap. Make sure to loosen the cap slowly to release any remaining pressure.

Radiator cleaning is performed while the engine is running. Take extreme caution when working on or near a running engine. Make sure to lock out and tag the controls notifying personnel that service work is being performed.

Do not remove the radiator cap unless it is required. Observe the coolant level in the coolant recovery tank.

---

1. When the engine is cold, remove the radiator cap and check the coolant level inside the radiator. Do not rely on the level of coolant in the coolant recovery tank. Refill radiator as required. Refer to coolant concentration table. (See page 4-80)
2. Check to make sure that the coolant transfer line from the coolant recovery tank to the radiator is free and clear of obstructions, or not pinched.
3. Observe the level of coolant in the coolant recovery tank. The normal cold engine fluid level should be between "FULL" and "LOW" marks on tank.
4. If the coolant is below the "LOW" mark, add coolant to this tank.

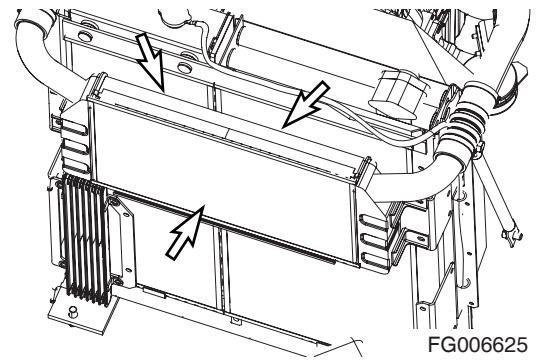

Figure 27

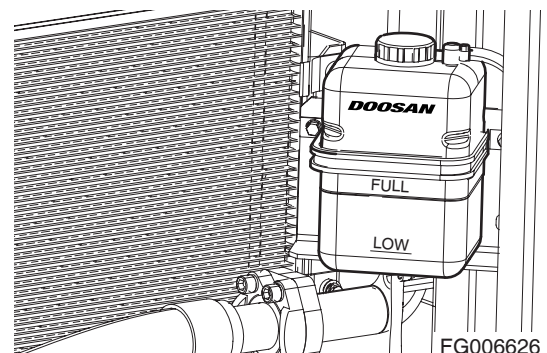

Figure 28

## Check Level of Window Washer Liquid

1. Open left access door and check fluid level in windshield washer tank (Figure 29).
2. Open fill cap and add fluid.

**NOTE:** Use a washer liquid that is rated for all seasons. This will prevent freezing during cold weather operation.

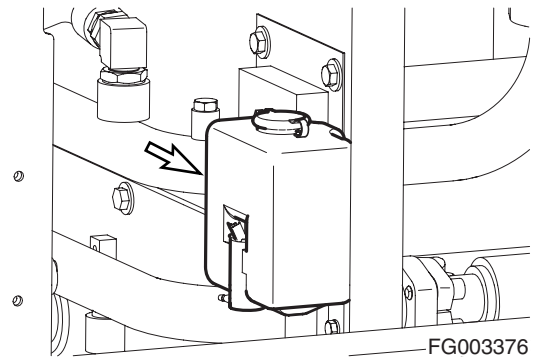
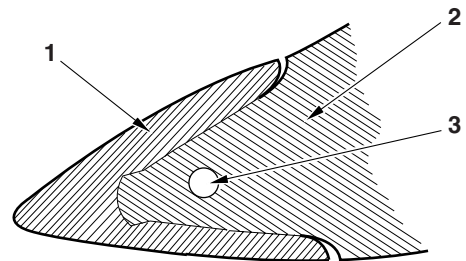

Figure 29

## Inspect Bucket Teeth and Side Cutters for Signs of Wear

1. On a daily basis, inspect the bucket teeth to make sure that tooth wear or breakage has not developed.
2. Do not allow the replaceable bucket teeth to wear down to the point that the bucket adapter is exposed. See Figure 30.

**NOTE:** These instructions are only for DOOSAN OEM buckets. If you are using other manufacturers' buckets, refer to their specific instructions.



FG000420

Figure 30 1. Point, 2. Adapter and 3. Pin

## Inspect Cooling Fan Blade



**WARNING!**

---

Personal injury can result from a fan blade failure. Never pull or pry on the fan. This can damage the fan blade(s) and cause fan failure.

---

1. An inspection of the cooling fan is required daily. Check for cracks, loose bolts, bent or loose blades, and for contact between the blade tips and the fan shroud. Check the fan to make sure it is securely mounted. Tighten the bolts if necessary. Replace any fan that is damaged.

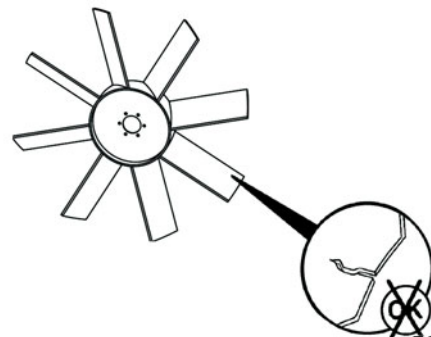

Figure 31

## Check Air Intake System



---

Hot engine components can cause burns.

Avoid contact with hot engine components

---

1. Park the machine on a level surface, lower the attachment to the ground, set safety lever and stand to "LOCK" position, and shut down engine.
2. Check the engine intake hose, and hose bands for damage and tightness.
3. If damaged, wrinkled, or loose, replace or retighten or contact your nearest *DOOSAN* dealer.

---

### IMPORTANT

---

Severe engine damage will result from running with unfiltered air.

Do not operate engine if any leaks or defects are found on air intake system.

---

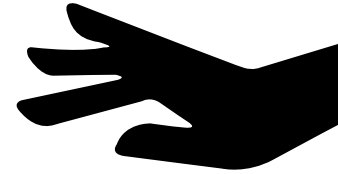

HAOA050L

Figure 32

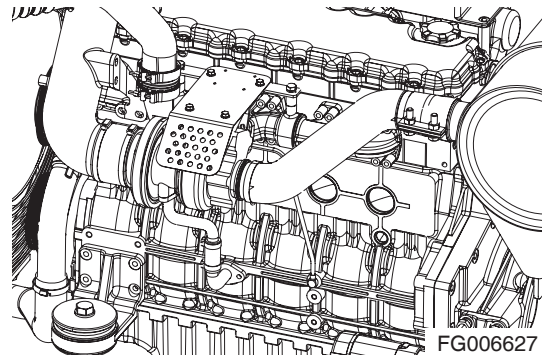

FG006627

Figure 33

## Inspect Seat Belt for Proper Operation

### Inspect Structure for Cracks and Faulty Welds

1. During the daily walk-around inspection and when greasing the machine, look for any visible damage to the machine. Repair or replace any damaged parts before operating the machine.

### Check Operation of All Switches

1. Verify working condition of all switches before starting the engine.

## **Check Operation of All Exterior Lights, Horn and Control Console Indicator and Monitor Lights**

1. Turn engine starter switch to the "I" (ON) position and observe all of the indicator lights.
2. Restore operation of any light bulbs that do not turn "ON" at this time.
3. Sound the horn. Repair or replace if required.
4. Turn "ON" and inspect all exterior work lights. Replace any monitors, burned out bulbs or cracked or broken housings or lenses.

## **Start Engine, Check Starting Ability, and Observe Exhaust Color at Start-up and at Normal Operating Temperature. Listen for Any Abnormal Sounds**

### **Check Operation of All Controls**

---

## **IMPORTANT**

---

**Cold weather operation requires that the operator fully warm up the hydraulic oil before beginning machine operation. Follow all warm up instructions listed in the Operating Instruction section of this manual. Make sure to cycle oil through all of the components, including all cylinders, both travel motors and the swing motor. Cold hydraulic oil in the lines and components needs to be warmed before beginning full operation. If this is not done, damage to the cylinders or hydraulic motors can occur.**

---

1. With the engine at rated speed, operate all of the controls.
2. Follow cold weather hydraulic system warm-up procedures.
3. Note any slow operations or unusual movements. Determine the cause and repair the fault before operating.

# 50 HOUR / WEEKLY SERVICE

## Perform All 10 Hour / Daily Service Checks

### Grease Boom, Arm and Front Attachment Pins

Grease every 10 hours for first 100 hours and every 50 hours thereafter.

**NOTE:** *If the unit has been running or working in water the front attachment should be greased on a 10 hour / daily basis.*

- Position machine as shown below and lower the front attachment to the ground and shut down engine
- Press the grease fitting and inject grease with the grease gun on the marked point
- After injection, clean off the old grease that has been purged.

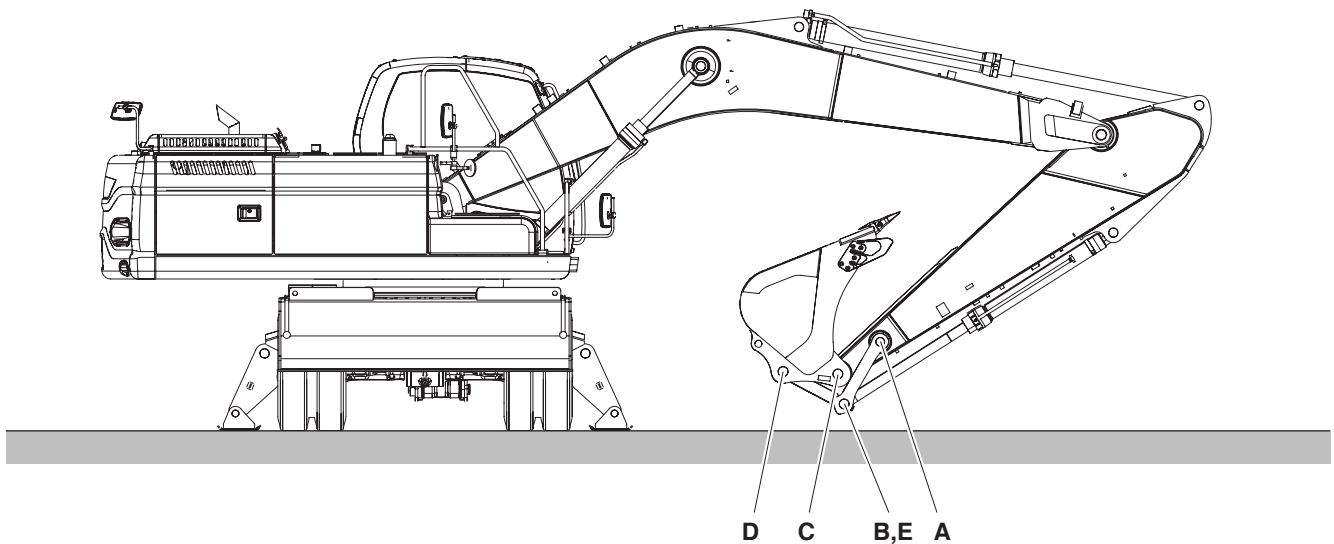

FG006628

Figure 34

Reference Number	Description
A	Arm Link Joint Pin (1 Point)
B	Link Joint Pin (2 Points)
C	Arm Bucket Joint Pin (1 Point)

Reference Number	Description
D	Bucket Link Joint Pin (1 Point)
E	Bucket Cylinder Rod Pin (1 Point)

- A. Arm Link Joint Pin (1 Point)
- B. Link Joint Pin (2 Points)
- C. Arm Bucket Joint Pin (1 Point)
- D. Bucket Link Joint Pin (1 Point)

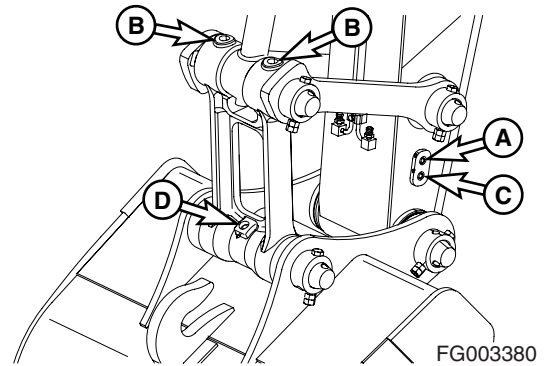

Figure 35

- E. Bucket Cylinder Rod Pin (1 Point)

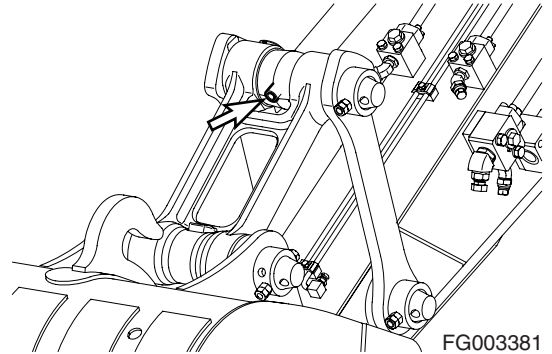

Figure 36

## Grease Swing Bearing

1. There are three grease fittings for the swing bearing. Do not over lubricate. Purge old grease with new. Remove all purged grease.

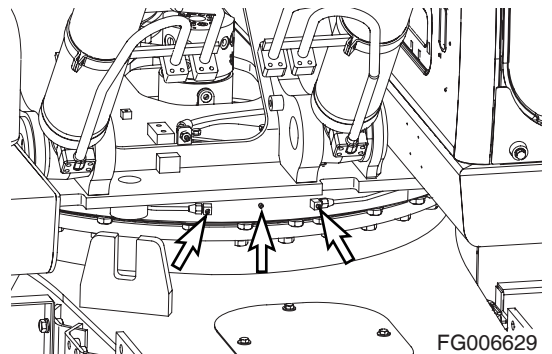

Figure 37

## Grease Dozer Blade Pin

**NOTE:** Grease it per 10 hours during initial period of 100 hours after buying your new vehicle, after which period grease it per 50 hours.

**NOTE:** In case of performing work underwater, grease it per 10 hours irrespective of elapsed period.

1. Remove chain connecting between dozer cylinder protection cover and chassis frame out of this chassis frame.
2. Completely open the dozer cylinder protection cover.
3. Inject grease at total 10 points by 5 points per dozer cylinder by means of using grease gun.
4. Neatly remove old grease that has leaked out after greasing.
5. Shut dozer cylinder protection cover after finishing greasing and then connect the chain to the chassis frame.

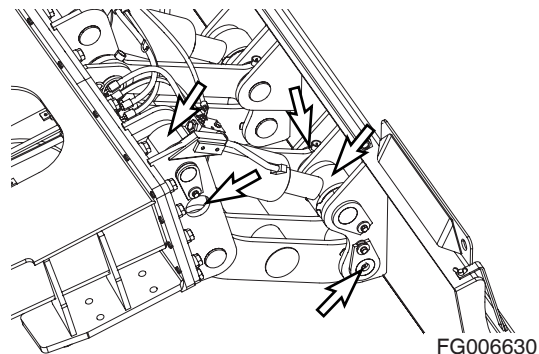

Figure 38

## CAUTION!

In order to avoid malfunction when opening dozer cylinder protection cover, you must work it after fixing the facilities on a planar ground surface and then putting down the dozer blade. When opening dozer cylinder protection cover, take heed so that the cover would not be shut off by external shock etc.

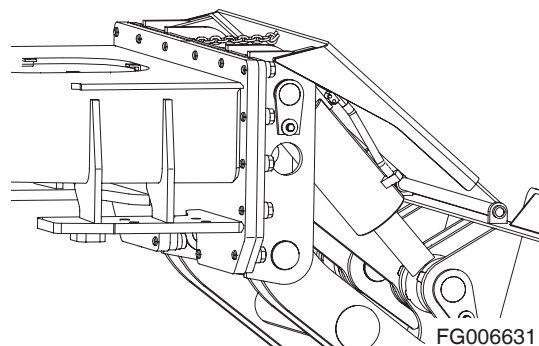

Figure 39

## Grease Outrigger Pins

Grease every 10 hours for first 100 hours and every 50 hours thereafter.

**NOTE:** If the unit has been running or working in water the outrigger should be greased on a 10 hour/daily basis.

- Position machine as shown Figure 40 and lower the outrigger leg to the ground and shut down engine.
- Press the grease fitting and inject grease with the grease gun on the marked points.
- There are a total of 8 grease points, 4 on each cylinder of the outrigger.
- After injection, clean off the old grease that has been purged.

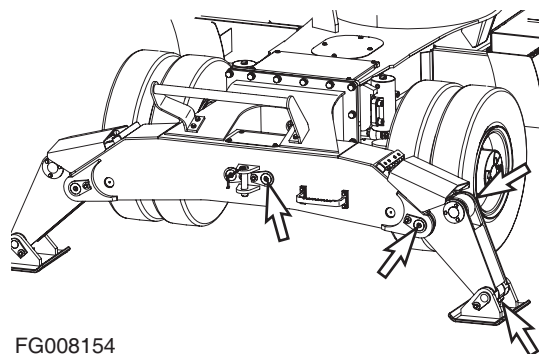

Figure 40

## Grease Front Axle Pin

**NOTE:** *If the unit has been running or working in water the front attachment should be greased on a 10 hour / daily basis.*

1. Lower the front attachment to ground.
2. Press the grease fitting and inject grease with the grease gun on the marked point.
3. After injection, clean off the old grease that has been purged.

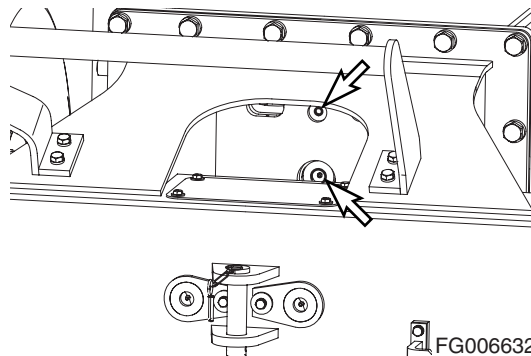

Figure 41

## Drain Water and Sediment from Fuel Tank

1. Perform this procedure before operating the machine.
2. Drain water and sediment from bottom of fuel tank into a suitable container.

**NOTE:** *Dispose of drained fluid according to local regulations.*

**NOTE:** *Always completely fill fuel tank at end of each workday to prevent condensation from forming on the inside walls of the tank.*

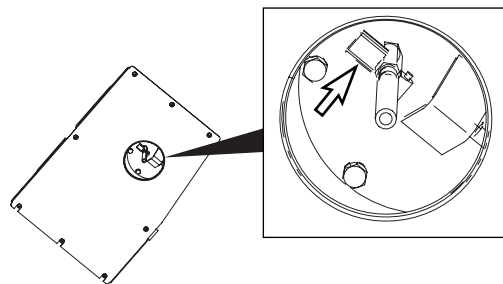

FG006633

Figure 42

## Check Engine Fan Belt for Cracks, Wear and Correct Tension (After First 50 Hours)

1. Inspect after first 50 hours of operation and every 150 hours thereafter. (See page 4-28)

## Change Engine Oil and Filter (After First 50 Hours)

1. Change engine oil and filter after first 50 hours of operation or rebuild, then every 150 thereafter. (See page 4-28)

## Inspect for Any Loose or Missing Nuts and Bolts

1. All nuts and bolts must be inspected after first 50 hours of operation. There after every 250 hours.

# 250 HOUR SERVICE

## Perform All 10 Hour / Daily and 50 Hour Service Checks

### Grease Arm and Front Attachment Pins

Grease every 10 hours for first 100 hours and every 250 hours thereafter.

**NOTE:** *If the unit has been running or working in water the front attachment should be greased on a 10 hour / daily basis.*

- Position machine as shown below and lower the front attachment to the ground and shut down engine.
- Press the grease fitting and inject grease with the grease gun on the marked point.
- After injection, clean off the old grease that has been purged.

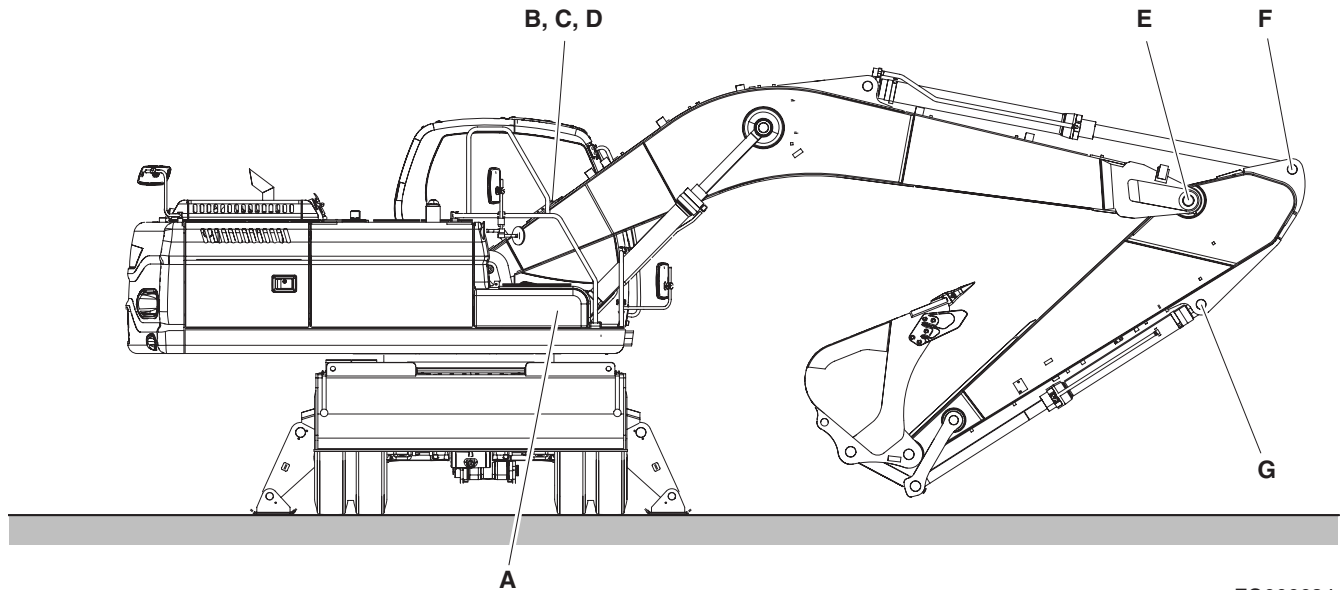

FG006634

Figure 43

Reference Number	Description
A	Boom Cylinder Head Pin (2 Points)
B	Boom Foot Pin (2 Points)
C	Boom Cylinder Rod Pin (2 Points)

Reference Number	Description
D	Arm Cylinder Head Pin (1 Point)
E	Boom, Arm Joint Pin (2 Points)
F	Arm Cylinder Rod Pin (1 Point)
G	Bucket Cylinder Head Pin (1 Point)

A. Boom Cylinder Head Pin (2 Points)

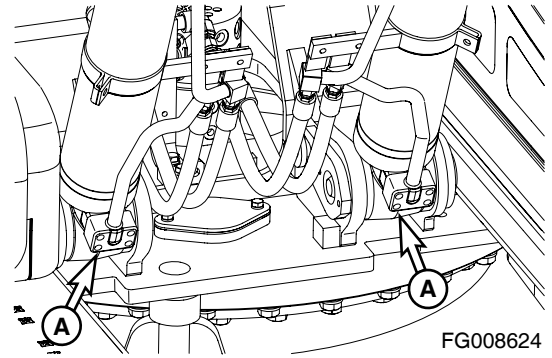

Figure 44

B. Boom Foot Pin (2 Points)

C. Boom Cylinder Rod Pin (2 Points)

D. Arm Cylinder Head Pin (1 Point)

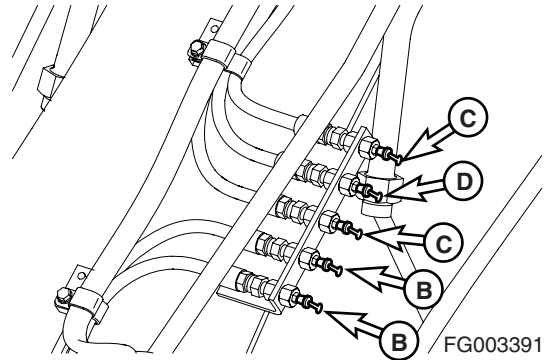

Figure 45

E. Boom, Arm Joint Pin (2 Points)

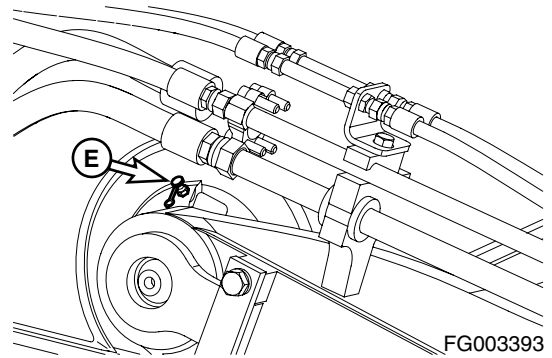

Figure 46

F. Arm Cylinder Rod Pin (1 Point)

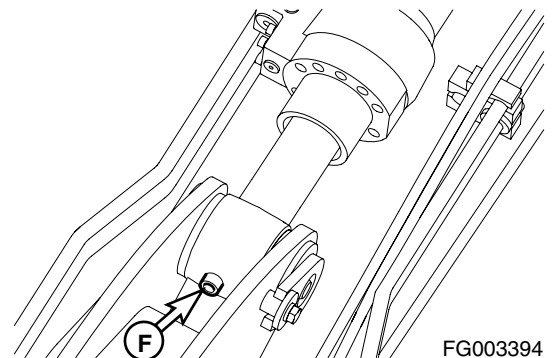

Figure 47

G. Bucket Cylinder Head Pin (1 Point)

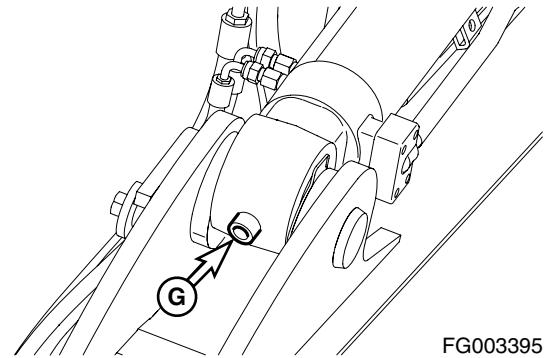

Figure 48

FG003395

## Check Engine Fan Belt for Cracks, Wear and Correct Tension

---

### IMPORTANT

---

A loose fan belt can cause engine overheating, poor charging, and/or premature belt wear. A belt that is too tight can cause damage to the water pump, alternator bearing or belt.

---

1. Inspect every 250 hours. (Inspect after first 50 hours of operation.)
2. With the engine shut off, check the tension of the fan belt by pressing downwards on the belt, midway between the fan pulley and alternator pulley. The belt should flex approximately 10 mm (0.4 in). See Figure 49. To adjust the belt, loosen the alternator adjustment plate bolts, adjust the belt tension and retighten the bolts.

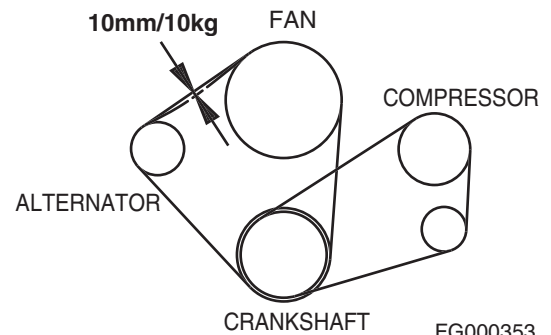

Figure 49

FG000353

## Check Engine Fan Belt Wear



### WARNING!

Keep clear of engine fan and fan drive belts when the engine is running. Rotating fan and belt contact can cause injury.

---



### WARNING!

When checking, adjusting or replacing drive belts, care must be taken to prevent accidental cranking of the engine. Be sure the starter switch is in the "OFF" position and the controls are tagged.

---

1. Replace badly worn, greasy or severely cracked belts immediately. These conditions prevent proper belt function. Visually inspect the belt. Check the belt for intersecting cracks. Transverse (across the belt width) cracks are acceptable. Longitudinal (direction of belt length) cracks that intersect with transverse cracks are not acceptable. Replace the belt if it is frayed or has pieces of material missing.
2. Before installing new belts, make sure all pulley grooves are clean and not worn. Replace pulley, if damaged, or if the grooves are worn.
3. All pulley support bearings, shafts, and brackets must be in working order.
4. When replacing belts and pulleys, pulley alignment must be checked with belts tensioned and brackets securely clamped. A misalignment that can be detected by the naked eye is detrimental to belt performance.
5. Do not force the belts into the pulley grooves by prying with a screwdriver or pry bar. This will damage the belt side cords which will cause the belts to turn and result in complete destruction of the belts in operation.
6. Belts on new machines and replacement belts lose their tension as they seat into the pulley grooves. Check the tension of new belts at 50 hour intervals until tension is stabilized and thereafter, every 250 hours. If the tension falls below the required minimum, the belt slips damaging the belts and pulley grooves.

**NOTE:** *When operating in abrasive conditions, check tension every 100 hours.*

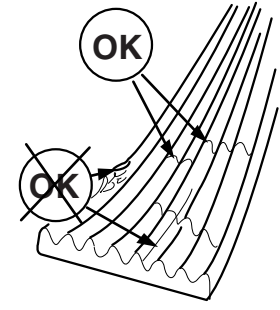
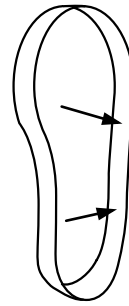

HAAA4030

Figure 50

## Change Breaker Filter Element (Optional)



The hydraulic oil will be hot after normal machine operation. Allow the system to cool down before changing pilot filter.

1. Position the machine on firm, level ground. Lower the front attachment to the ground and shut down engine.
2. Loosen the hydraulic oil tank breather cap to release pressure.
3. Locate breaker filter assembly (Figure 51)
4. Position a container under the filter assembly. Remove the drain plug and completely drain the assembly.
5. Using a 30 mm spanner, unscrew, unscrew filter housing from filter bottom.
6. Remove O-ring from filter head.
7. Replace filter.
8. Apply a small amount of oil around the entire O-ring and install the filter housing on the filter head.  
**NOTE:** *Tightening torque : 27 kg•m (265 N•m, 195 ft lb)*
9. Install drain plug in bottom of filter housing.
10. After changing breaker filter, vent air from pump and check level of hydraulic oil tank.

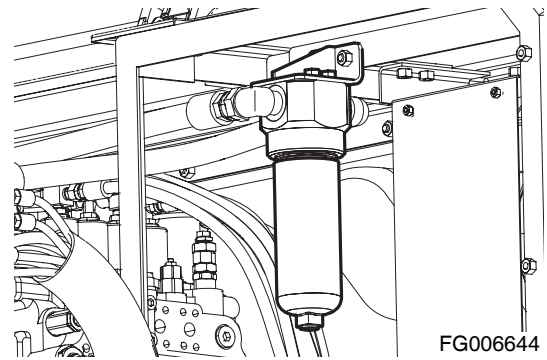

Figure 51 Breaker Filter

## Change Swing Reduction Device Oil (Drain and Refill After First 250 Hours)

**NOTE:** *Change swing reduction device oil after 250 hours on a new machine and every 2,000 hours thereafter. (See page 4-53)*

## Replace Full Flow Hydraulic Oil Filter (After First 250 Hours)

**NOTE:** *Replace full flow hydraulic oil filter after 250 hours on a new machine and every 1,000 hours thereafter. (See page 4-56)*

## Change Pilot Filter (After First 250 Hours)

**NOTE:** *Change pilot filter after 250 hours on new machine and every 1,000 hours thereafter. (See page 4-48)*

## **Change Brake Filter (After First 250 Hours)**

**NOTE:** *Replace brake filter after 250 hours on new machine and every 1,000 hours thereafter. (See page 4-49)*

## **Inspect Pins and Bushings of Front End Attachments for Signs of Wear**

## **Check Fluid Levels in Batteries and Battery Charge Levels**

## **Inspect for Any Loose or Missing Nuts and Bolts**

## **Inspect Fuel System Hose Clamps**

# 500 HOUR / 3 MONTH SERVICE

## Perform All Daily, 50 and 250 Operating Hour Service Checks

### Grease Swing Gear and Pinion

---



## WARNING!

---

Greasing swing gear and pinion must be serviced by only one person.

---

1. Remove inspection cover and inspect the condition of the grease. Make sure that water or other contaminants are not noticeable.

**NOTE:** *The upper structure must be rotated a little at a time so that the entire face of the swing gear can be lubricated. Use extreme caution when performing this operation.*

2. If water or other contaminations are found, remove the lower access cover so that the gear teeth can be thoroughly cleaned and lubricated.
3. Install access covers after lubricating gear teeth.

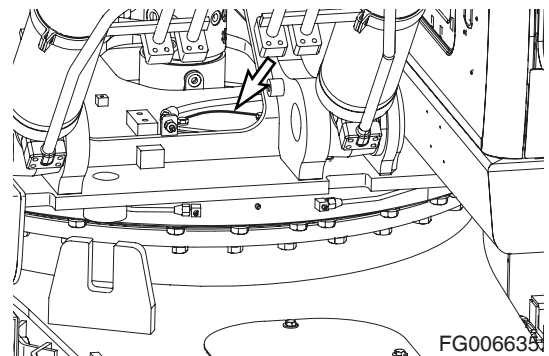

Figure 52

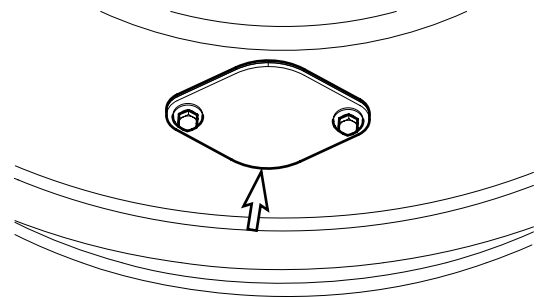

Figure 53

## Change Engine Oil and Filter

**NOTE:** Change engine oil and filter after first 50 hours of operation or rebuild, then every 500 thereafter.



**DO NOT** change oil on a hot engine. Allow the engine to cool down before attempting to change the engine oil and filter to avoid burns by touching hot engine parts.

1. Position a larger container under the engine. Remove cap (1, Figure 54) and install hose (2) to drain the engine oil. Remove hose (2) and install cap (1).

**NOTE:** Dispose of drained fluids according to local regulations.

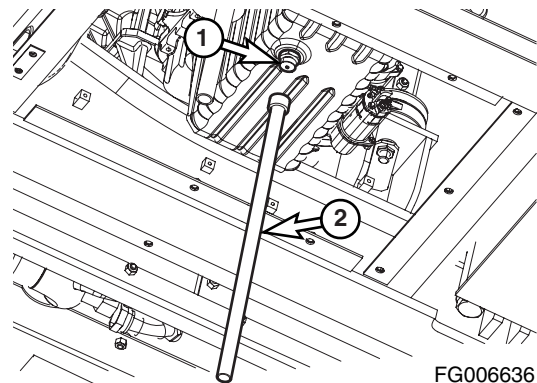

Figure 54

2. Replace engine oil filter by using filter wrench. The engine oil filter is a spin-on type. See Figure 55. Remove and discard filter.
3. Install new filter. Apply a small amount of oil around filter gasket. Screw filter on head until gasket contacts head, turn filter 1/2 turn more.

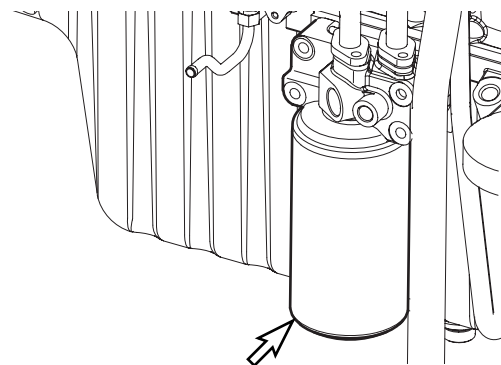

Figure 55

4. Refill the engine with the correct oil through the oil fill port (Figure 56). Refer to the Lubrication Table of this manual for the recommended oil for the operating conditions.

**NOTE:** See "Fluid Capacities" on page 4-8. for capacity.

5. Start engine. Run engine for five minutes at "LOW IDLE," and check engine oil pressure light.
6. Shut down engine. Look for signs of leaks at filter. Recheck oil level after fifteen minutes.

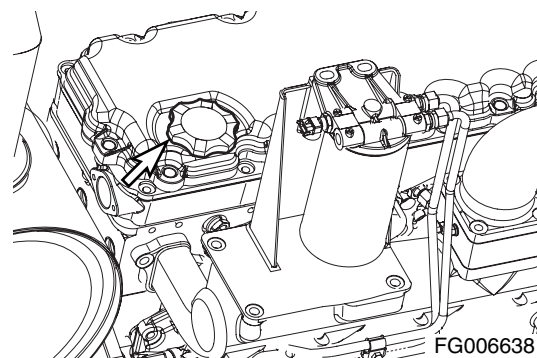

Figure 56

## Clean Air-Conditioning Outer Filter

The unit is equipped with an air filtration system which filters out dirt and dust particles from air being circulated into operator's cabin. This filter should be cleaned out.

**NOTE:** *In the event that the unit is being operated in a dusty environment, the cleaning and replacement should be performed more frequently. If filter is damaged, replace damaged filter with a new one.*



### WARNING!

---

All service and inspection of air-conditioning system should be performed with the starter switch in the "O" (OFF) position.

---



### WARNING!

---

If using compressed air to clean the element, make sure that proper eye protection is worn.

---

**NOTE:** *All right and left call outs are based on the operator being seated in the operator's seat facing the front.*

1. Open the door in the left of the machine.

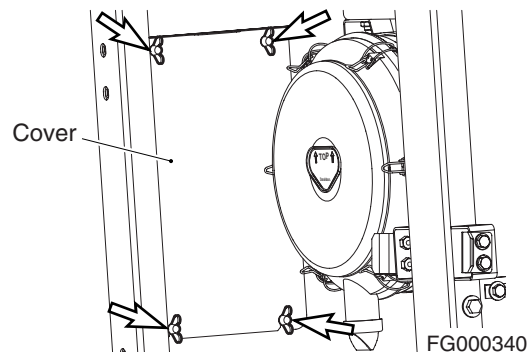

Figure 57

2. Open the cover by turning the knob (1, Figure 58) in the rear of the cabin.

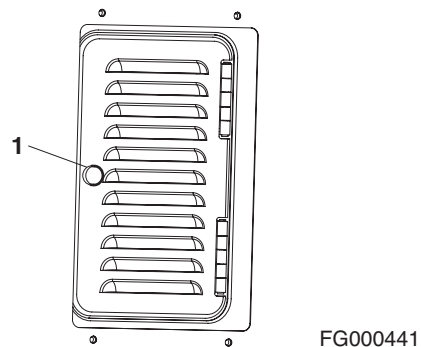

Figure 58

3. Remove filter (Figure 59) and inspect for any damage.
4. Use compressed air to clean filter. If filter is still dirty, then change to new one.
5. Reassemble in reverse order.

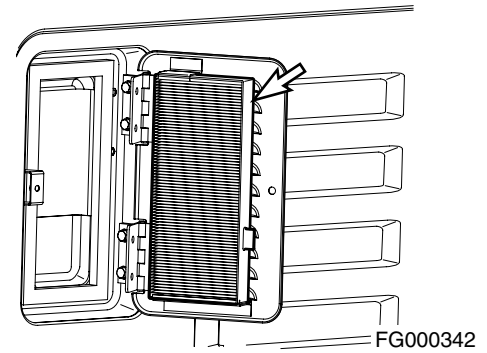

Figure 59

## Check and Clean Air-Conditioning Inner Filter

---

**! WARNING!**

All service and inspection of air-conditioning system should be performed with the starter switch in the "O" (OFF) position.

---

**! WARNING!**

If using compressed air to clean the element, make sure that proper eye protection is worn.

---

1. Remove the filter by pulling out ward the knob while pressing the upper part and lower part of the filter handle which is inside of the left rear part of the cabin.
2. Use compressed air in the clean filter. If the filter is damaged replaced by a new one.  
If the filter is very dirty use a mild soap or detergent and water to clean it.

---

## IMPORTANT

If water was used to clean filter, be certain it is completely dry before installing.

---

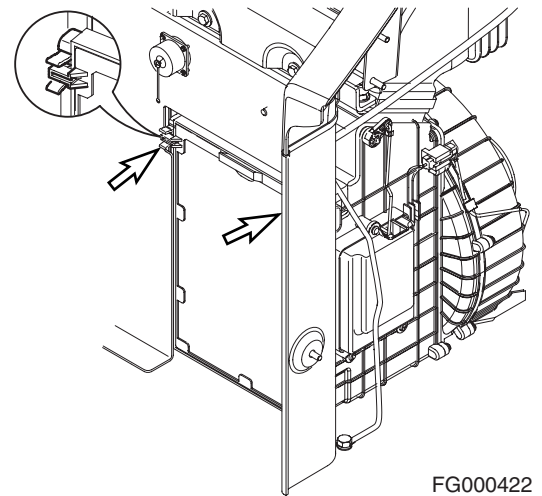

Figure 60

# Clean Radiator, Oil Cooler, Intercooler, Fuel Cooler and Air Conditioner Condenser Core

## **WARNING!**

If compressed air, steam or water hit your body directly, there is danger of injury. Always wear protective glasses, mask and safety shoes during the cleaning process. Make sure that all extra personnel are clear of the work area.

1. Open the left door and engine cover.
2. Loosen the wing bolt(s) and remove dust net from in front of oil cooler and intercooler.
3. Clean the outside of the radiator and oil cooler, intercooler and fuel cooler with compressed air, steam or water. Wash from the outside of the engine compartment inwards. Repeat the cleaning process from the inside of the engine compartment outwards to remove all dirt and debris.

**NOTE:** Clean dust net and install it after cleaning radiator, oil cooler, intercooler and fuel cooler.

4. Clean air conditioner condenser core with compressed air, steam or water.

## **IMPORTANT**

To prevent damage to the cores, apply compressed air from an appropriated distance. Damaged core may cause water leakage or overheating. In a dusty site, check the core daily, irrespective of the maintenance interval.

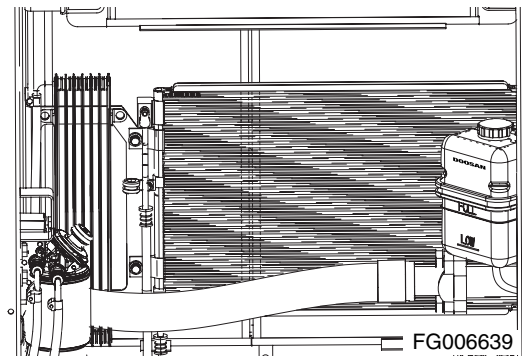

Figure 61

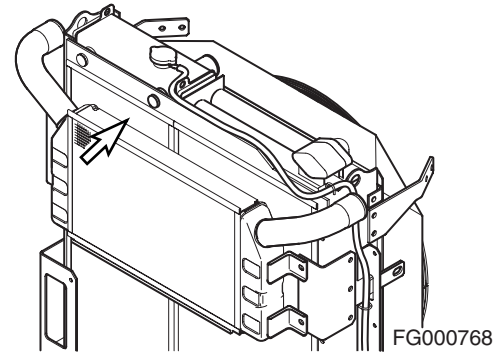

Figure 62

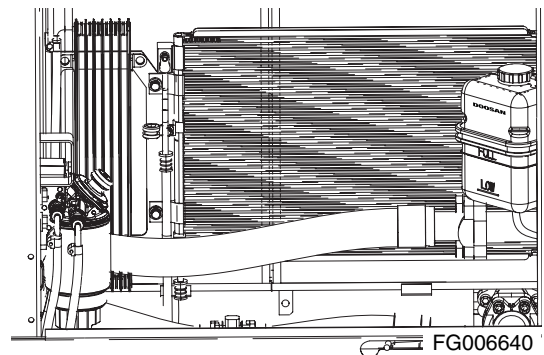
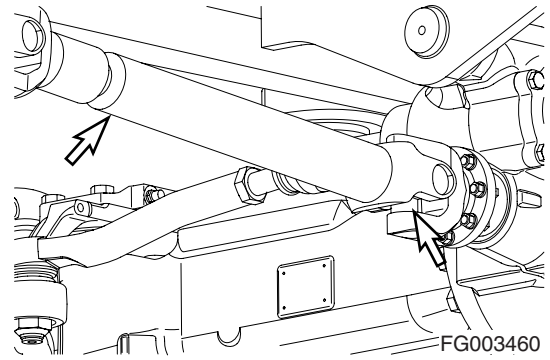

Figure 63

## Grease Drive Shaft

1. Front Drive Shaft Front U-joint (1 Point)
2. Front Drive Shaft Spline (1 Point)



**Figure 64**

3. Front Drive Shaft Rear U-joint (1 Point)
4. Center Drive Shaft Front Bearing (1 Point)

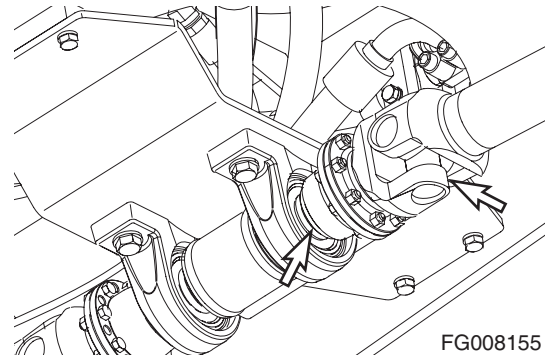

**Figure 65**

5. Center Drive Shaft Rear Bearing (1 Point)
6. Rear Drive Shaft Front U-joint (1 Point)

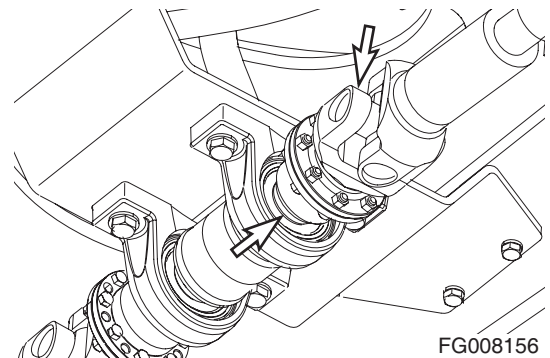

**Figure 66**

7. Rear Drive Shaft Spline (1 Point)
8. Rear Drive Shaft Rear U-joint (1 Point)

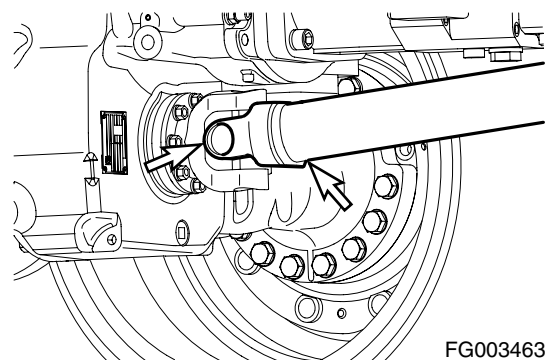

**Figure 67**

## Grease Front Axle Steering Knuckle (2 X 2 points, 4 points)

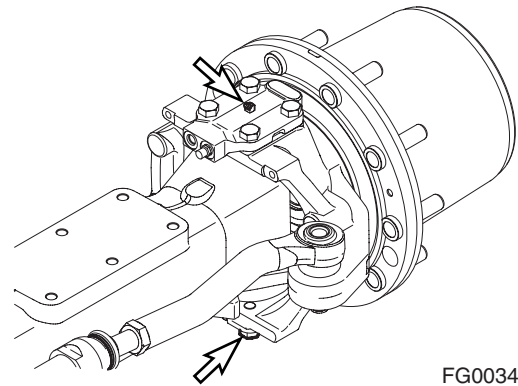

Figure 68

FG003464

## Clean Outer Filter of Air Cleaner

**NOTE:** Clean outer filter every 500 hours / 3 months of service.

**NOTE:** If air cleaner clogged warning light (Figure 69) on instrument panel comes "ON" the air cleaner must be serviced.

**NOTE:** When working in severely dusty conditions, the service interval should be shortened.

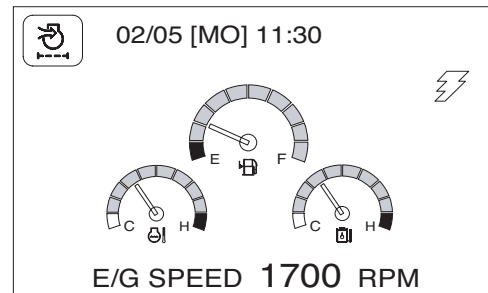

Figure 69

FG000264

## **WARNING!**

Never clean or attempt to remove the air cleaner filter if the engine is running.

If using compressed air to clean the filter, make sure that proper eye protection is worn.

1. Locate the air cleaner assembly.

**NOTE:** When it reaches every 500 hours or If indicator light (Figure 69) on instrument panel comes "ON" the air cleaner must be serviced.

**NOTE:** Replace outer filter after cleaning 5 times or every 2,000 hours / 1 year of service.

2. Remove and clean rubber evacuator valve (1, Figure 70) from bottom of air cleaner housing cover (2). Inspect seal lips for wear or damage. Replace valve if necessary.

**NOTE:** Install evacuator valve with lips parallel to the cover.

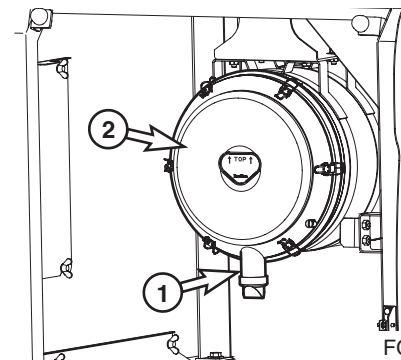

Figure 70

FG000297

3. Remove the access cover (2, Figure 71) by loosening the latches (3).
4. Remove the outer filter (4, Figure 71) from the housing. Do not remove inner filter (5).

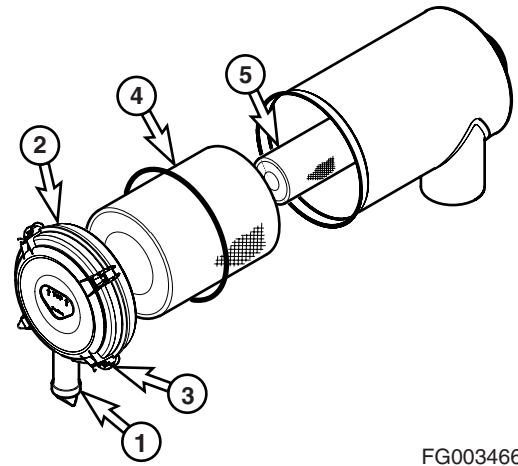

Figure 71

FG003466

5. Clean the outer filter (4, Figure 71) by blowing compressed air from the inside of the filter towards the outside. Do not use more than 205 kPa (30 psi) air pressure.

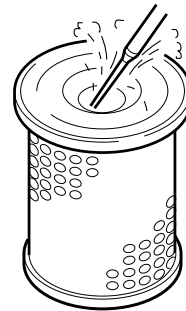

Figure 72

HAOC570L

6. Check outer filter by shining a light through it. If small holes or thinner parts are found on the element after cleaning it, replace the filter.
7. Clean the inside of the air cleaner body and the inside of the air cleaner cover. Do not use compressed air.
8. Properly install the air filter and cover.
9. After filter service be sure to install cover with arrows pointing "UP."

**NOTE:** *If after cleaning the outer filter, the air cleaner clogged indicator remains "ON," replace the outer and inner filters. Do not clean inner filter.*

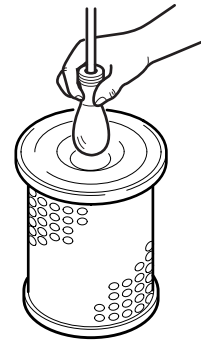

Figure 73

FG000412

## Change of Fuel Prefilter

1. Open the left side door to access fuel prefilter.
2. Position a small container under prefilter. Drain fuel by opening drain valve on bottom of filter.

**NOTE:** *Dispose of drained fluids according to local regulations.*

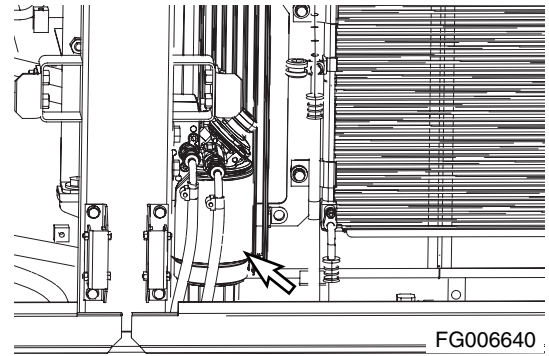

Figure 74

3. Remove the bowl using supplied tool.
4. Remove the cartridge.

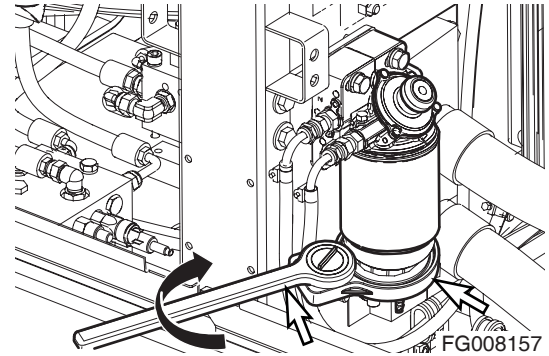

Figure 75

5. Coat surface of packing (2, Figure 76) with fuel on new cartridge (1).
6. Tighten the cartridge by hand until the packing comes into contact with the surface of the filter housing head.
7. When it reach the surface, tighten the cartridge about 3/4 of a turn more.
8. Coat surface of seal (3, Figure 76) with fuel, and tighten the bowl with tool.

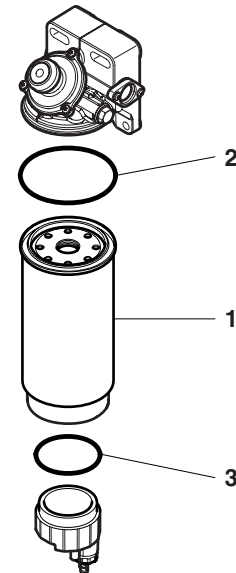

Figure 76

## Change Fuel Filter



### WARNING!

Exchange filter after waiting for engine to cool. Be careful of fire hazards. Do not smoke.

1. Locate fuel filter inside engine compartment.
2. Open the engine cover to access fuel prefilter.
3. Position a small container under fuel filter.
4. Unscrew fuel filter from head assembly. Discard fuel filter.

**NOTE:** *Dispose of drained fluids according to local regulations.*

5. After cleaning filter head, install new fuel filter. Screw filter on head until gasket contacts head, and turn filter 1/2 turn more with a filter wrench.

**NOTE:** *Coat fuel filter gasket with fuel.*

**NOTE:** *Fill fuel filter with clean fuel. This will help reduce fuel system priming.*

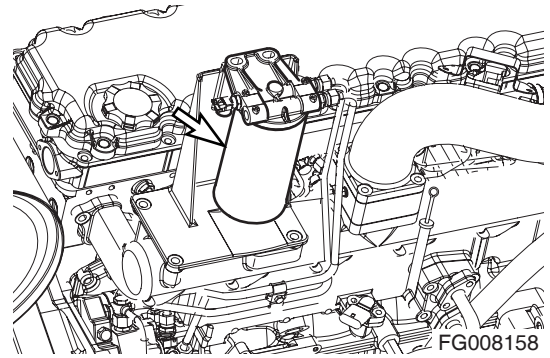

Figure 77

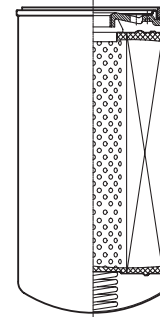

Figure 78

### Fuel System Priming

If air remains in the fuel inlet line to the engine, it may cause the engine to run in an abnormal condition. Air may impact the starting capability of the engine, and may also result in surging engine speeds.

If the machine happens to have run out of fuel, or if the fuel filter has been replaced, air may need to be bled using the following procedure:

1. Shut down engine.
2. Loosen plug (1, Figure 79) on the fuel prefilter head.
3. Pump the hand operated primer pump (2, Figure 79) on the fuel prefilter. Pump primer until fuel is present at plug hole in fuel prefilter head.
4. Tighten plug (1, Figure 79) in fuel prefilter head.
5. Continue to pump primer pump until a strong resistance is felt.
6. Start engine and look for signs of leaks.
7. Repeat procedure if necessary.

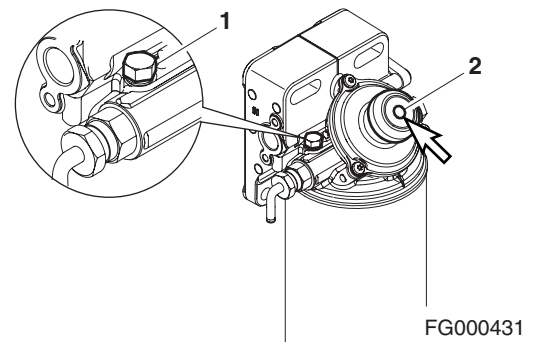

Figure 79

## **Drain and Refill Transmission Fluid**

1. The transmission fluid should be drained and refilled after the first 500 hours of operation and at every 2,000 hours thereafter (See page 4-58)

## **Drain and Refill Hub Reduction Gear Oil**

1. The hub reduction gear oil should be drained and refilled after the first 500 hours of operation or rebuild, and every 2,000 hours thereafter. (See page 4-59)

## **Drain and Refill Front Axle Case Oil**

1. The rear axle case oil should be drained and refilled after the first 500 hours of operation or rebuild, and every 2,000 hours thereafter. (See page 4-58)

## **Drain and Refill Rear Axle Case Oil**

1. The rear axle case oil should be drained and refilled after the first 500 hours of operation or rebuild, and every 2,000 hours thereafter. (See page 4-59)

# 1,000 HOUR / 6 MONTH SERVICE

## Perform All Daily, 50, 250 and 500 Operating Hour Service Checks

### Grease Swing Reduction Device

1. Position the machine on firm, level ground. Lower the front attachment to the ground and shut down engine.
2. Remove air vent plug (1, Figure 80) from swing reduction device.

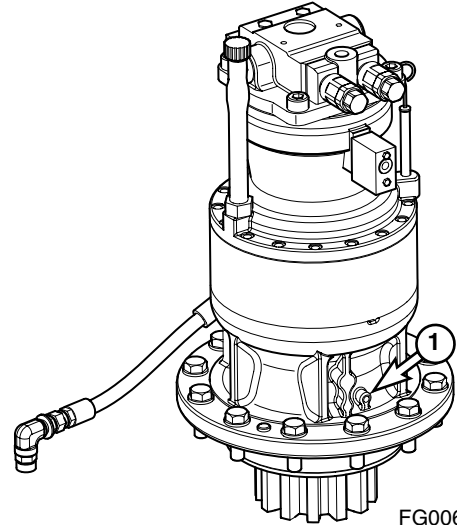

Figure 80

FG006642

3. Press grease fitting and inject grease with the grease gun on the marked point (2, Figure 81).
4. Install air vent plug (1, Figure 80) in swing reduction device.

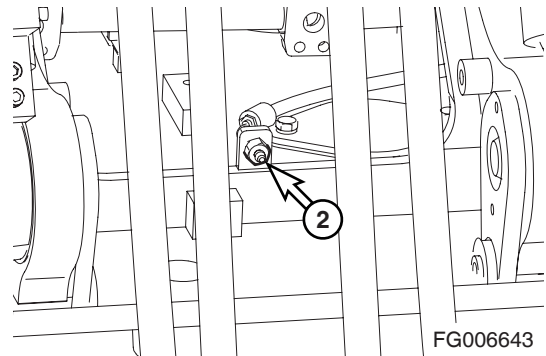

Figure 81

FG006643

## Replace Hydraulic Oil Return Filter

**NOTE:** Change hydraulic oil return filter after first 250 hours of operation or rebuild, and every 1,000 hours thereafter.

**NOTE:** If return filter clogged warning light (Figure 82) on instrument panel comes "ON" the return filter must be serviced.

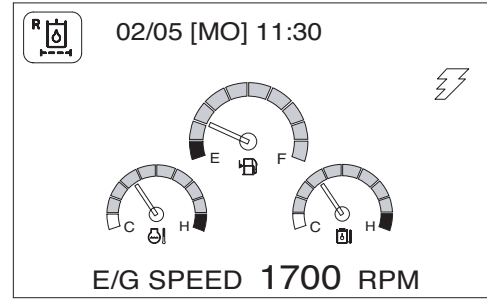

FG000760

Figure 82

---

## WARNING!

---

The hydraulic oil will be hot after normal machine operation. Allow the system to cool before attempting to service any of the hydraulic components.

The hydraulic tank is pressurized. Loosen the hydraulic breather cap slightly to allow the pressurized air to vent. After the pressure has been released, it is safe to remove either the breather cap or service covers or drain water from the tank.

---

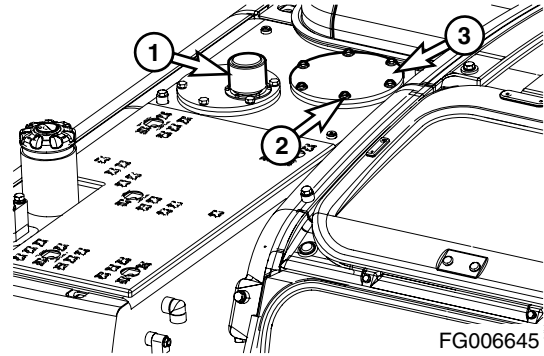

FG006645

Figure 83

---

## IMPORTANT

---

Make sure to clean any dirt or water from the top of the hydraulic tank, especially around the fill port and filter ports.

---

1. Position the machine on firm, level ground. Lower the front attachment to the ground and shut down engine.
2. Loosen the breather cap (1, Figure 83) slightly to release the internal pressure.
3. Remove bolts (2, Figure 83) and service cover (3). Remove spring (4), valve (5) O-ring (6), and bypass strainer (7), and then filter (8).

4. Remove filter and discard.

**NOTE:** Used filter should always be disposed of according to local regulations.

5. Install new filter and a new O-ring. Install bypass strainer, valve and spring. Install service cover plate.
6. Tighten the breather cap (1, Figure 83).
7. Run engine for ten minutes at low idle to purge air from circuit.
8. Check level in hydraulic oil tank (See page 4-16). Add oil if necessary.

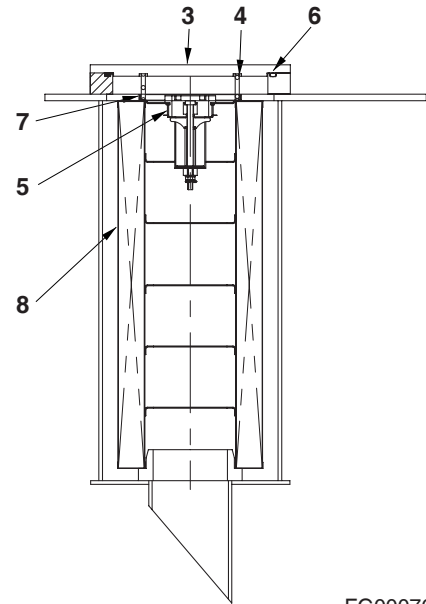

FG000761

Figure 84

## Change Pilot Filter

**NOTE:** Change pilot filter after first 250 hours of operation or rebuild, and every 1,000 hours thereafter.

**NOTE:** If pilot filter clogged warning light (Figure 85) on instrument panel comes "ON" the pilot filter must be serviced.

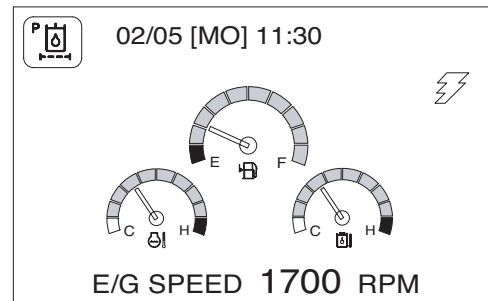

FG000763

Figure 85

---

### **WARNING!**

---

The hydraulic oil will be hot after normal machine operation.

Allow the system to cool down before changing pilot filter.

---

1. Position the machine on firm, level ground. Lower the front attachment to the ground and shut down engine.
2. Loosen the breather cap (1, Figure 83) slightly to release the internal pressure.
3. Locate pilot system filter assembly. See Figure 86.
4. Unscrew canister (5, Figure 87) and remove O-ring (3) and filter cartridge (4).

**NOTE:** The canister will be filled with oil. Use caution when removing this assembly.

5. Insert a new filter cartridge and O-ring. Apply a small amount of oil around the entire O-ring and install the canister assembly onto the filter head (1, Figure 87).

**NOTE:** Used filter should always be disposed of according to local regulations.

6. After changing pilot filter, vent air from pump and check level of hydraulic oil tank.

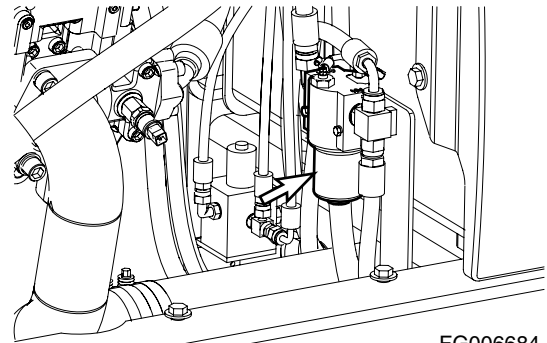

FG006684

Figure 86

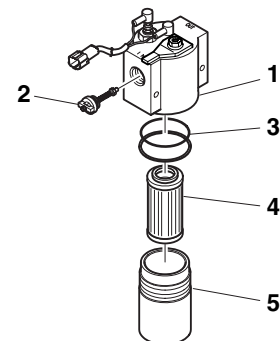

FG000323

Figure 87

## Change Brake Filter

**NOTE:** *Change brake filter after first 250 hours of operation or rebuild, and every 1,000 hours thereafter.*



### WARNING!

The hydraulic oil will be hot after normal machine operation.

Allow the system to cool down before changing brake filter.

1. Position the machine on firm, level ground. Lower the front attachment to the ground and shut down engine.
2. Loosen the breather cap (1, Figure 83) slightly to release the internal pressure.
3. Locate brake system filter assembly. See Figure 86.
4. Unscrew canister (5, Figure 87) and remove O-ring (3) and filter cartridge (4).

**NOTE:** *The canister will be filled with oil. Use caution when removing this assembly.*

5. Insert a new filter cartridge and O-ring. Apply a small amount of oil around the entire O-ring and install the canister assembly onto the filter head (1, Figure 87).

**NOTE:** *Used filter should always be disposed of according to local regulations.*

6. After changing brake filter, vent air from the breather of the front & rear axle and check level of hydraulic oil tank.

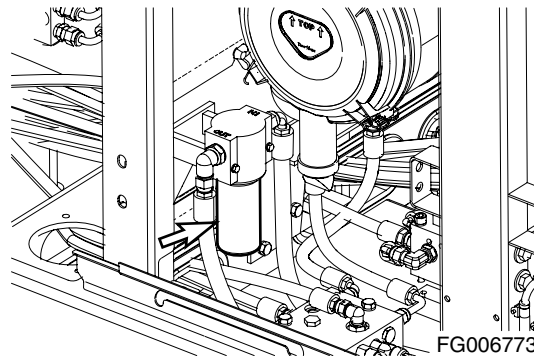

Figure 88

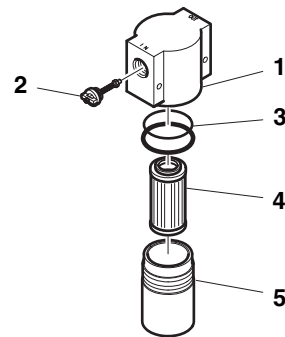

Figure 89

## Change Air-Conditioning Outer Filter

The unit is equipped with an air filtration system which filters out dirt and dust particles from air being circulated into operator's cabin. This filter should be cleaned out.

**NOTE:** *In the event that the unit is being operated in a dusty environment, the cleaning and replacement should be performed more frequently. If filter is damaged, replace damaged filter with a new one.*



All service and inspection of air-conditioning system should be performed with the starter switch in the "O" (OFF) position.

**NOTE:** *All right and left call outs are based on the operator being seated in the operator's seat facing the front.*

1. Open the door in the left of the machine, then remove four wing bolts and washers, and access cover (1, Figure 90).

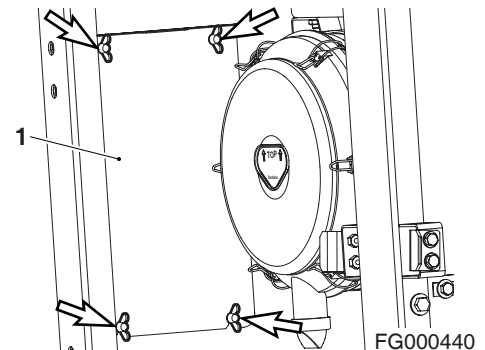

Figure 90

2. Open the cover by unscrewing the knob (1, Figure 91) in the rear of the cabin.

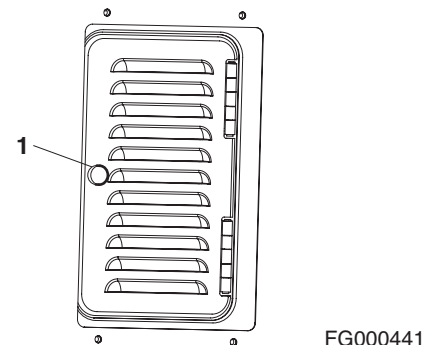

Figure 91

3. Remove filter (Figure 92) and replace with new one.
4. Reassemble in reverse order.

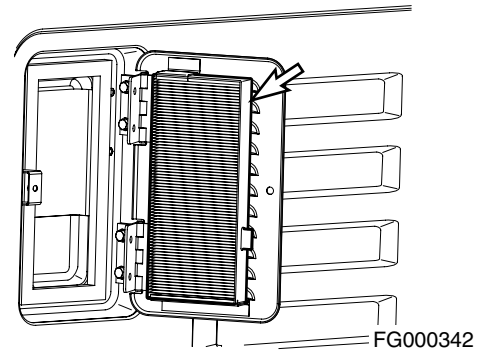

Figure 92

## Check Air Conditioner Refrigerant



Mixing of tobacco smoke and freon is deadly.

Do not smoke while servicing or recharging air-conditioning system.

1. Run engine at about 1,800 rpm. Operate for a minimum of ten minutes to stabilize the system.
2. Press the "HI" fan speed switch to set maximum air flow.
3. Put the temperature control switch in maximum cooling position.
4. Press the "Internal Air Circulation" switch.
5. Compare the flow of bubbles in the sight glass of receiver dryer with the drawings in the following table.



Overfilling refrigerant may cause dangerous high-pressure and poor cooling action; and low refrigerant level may cause compressor damage.

Always maintain refrigerant at normal level.

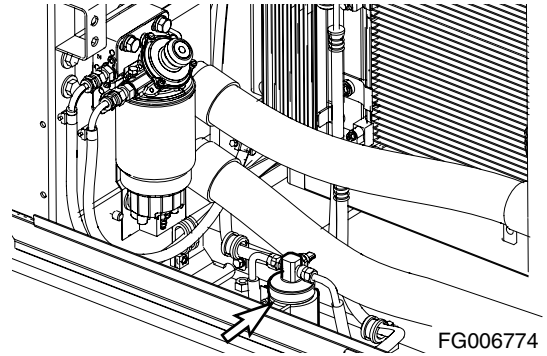
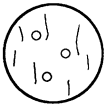
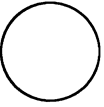
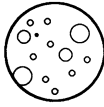

Figure 93

Amount of Refrigerant	Appearance of the Sight Glass	Solutions
Normal	 <p data-bbox="553 174 841 247">Almost clear. Any bubbles disappear.</p>	
High	 <p data-bbox="553 342 813 373">No bubbles are seen.</p>	Charge or withdraw the system with the correct amount of HFC-134a refrigerant.
Low	 <p data-bbox="553 478 878 510">A flow of bubbles is visible.</p>	

## Check and Adjust Engine \*\*

Contact your nearest *DOOSAN* dealer.

Engine dealer for checking and adjusting the following items:

- Engine Compression Pressure.
- Injection Pressure.
- Injection Timing.

# 2,000 HOUR / YEARLY SERVICE

## Perform All Daily, 50, 250, 500 and 1,000 Hour Service Checks

### Change Swing Reduction Device Oil

**NOTE:** Change swing reduction device oil after first 250 hours of operation or rebuild and every 2,000 hours thereafter.



## WARNING!

The gear oil is very hot after the machine has been operating. Shut all systems down and allow them to cool.

1. Set a container under excavator.
2. Remove cap (3, Figure 95) and install hose (4) to drain the swing reduction device oil.  
**NOTE:** Dispose of drained fluids according to local regulations.
3. After draining oil, remove hose and install cap.
4. Remove breather/fill cap (2, Figure 94) and add oil to "H" mark on dipstick (1).

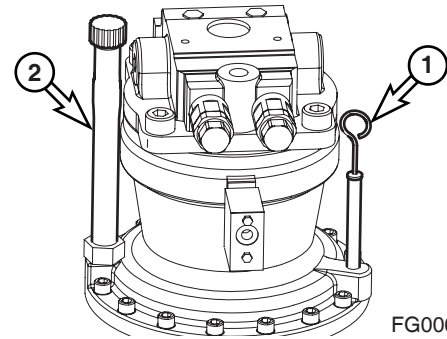

FG006599

Figure 94

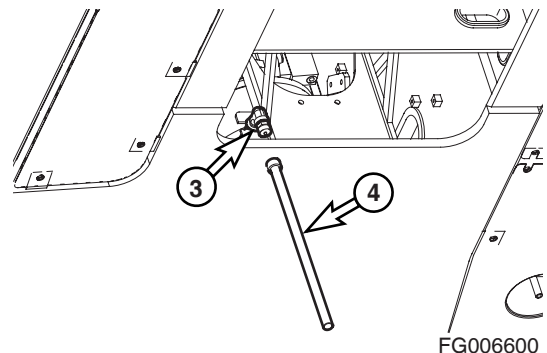

FG006600

Figure 95

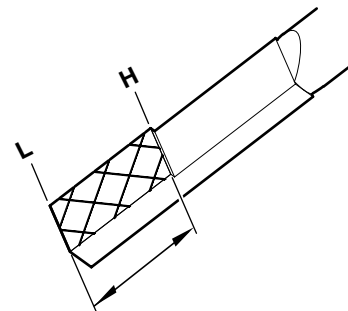

FG000419

Figure 96

## Replace Outer and Inner Air Cleaner Elements



### WARNING!

Never clean or attempt to remove the air cleaner element if the engine is running.

**NOTE:** Replace outer element after cleaning 5 times or every 2,000 hours of service.

**NOTE:** Replace inner element whenever a new outer element is installed.

If there is clogged filter signal on the gauge panel, use the following procedure.

1. Open the access door at the left of the machine.
2. Remove the evacuator valve (1, Figure 98) and air cleaner cover (2).

**NOTE:** Inspect evacuator valve seal lips for wear or damage. Replace valve if necessary. Install evacuator valve with lips parallel to the cover.

3. Remove outer filter (4, Figure 98) from the air cleaner housing.
4. Clean the air cleaner cover and the inside of the air cleaner housing.
5. Remove inner filter (5, Figure 99).
6. Clean out inside of air cleaner housing. Do not use compressed air to blow out housing.
7. Install new inner filter. Do not clean and reuse inner element.
8. Install new outer filter.
9. Install air cleaner cover and evacuator valve.

**NOTE:** Make sure that all gaskets and cover are properly installed and seated.

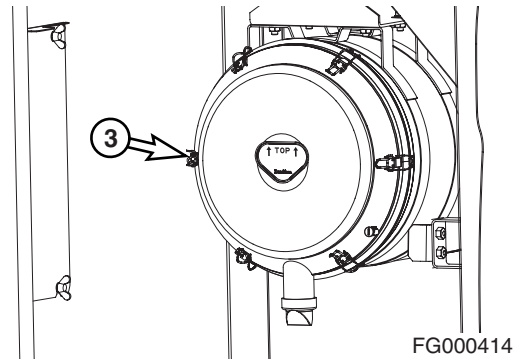

Figure 97

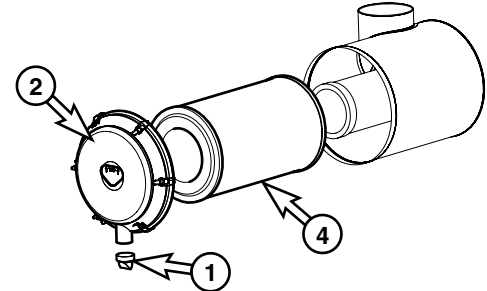

Figure 98

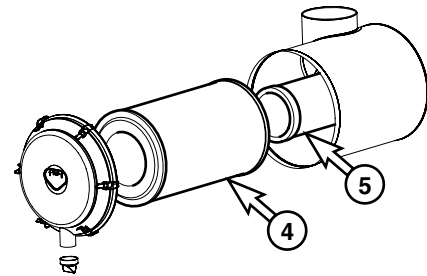

Figure 99

# Change Radiator Coolant

## **WARNING!**

Allow the engine to cool before releasing the radiator cap. Make sure to loosen the cap slowly to release any remaining pressure.

Radiator cleaning is performed while the engine is running. Take extreme caution when working on or near a running engine. Make sure to lock out and tag the controls notifying personnel that service work is being performed.

Do not remove the radiator cap unless it is required. Observe the coolant level in the coolant recovery tank.

1. Slowly open the radiator cap to allow any pressure to escape.
2. Place a container under the radiator and open the drain valve (2, Figure 101).

**NOTE:** *Dispose of drained fluids according to local regulations.*

3. Open heater shutoff valves (3 and 4, Figure 101) to allow coolant to drain from heater core.
4. Remove coolant drain plug (1, Figure 103) from engine.
5. Install drain plug, and close drain valve after coolant has completely drained from system.
6. Fill cooling system with a flushing solution.
7. Run engine at low idle until the coolant temperature gauge reaches the "BLUE ZONE." Run engine for another ten minutes.
8. Allow engine to cool.
9. Drain flushing fluid and fill system with water.
10. Run engine again to allow water to completely circulate.
11. After allowing engine to cool, drain water and fill system with proper antifreeze mixture for ambient temperature. Refer to coolant concentration table. See "Antifreeze Concentration Tables" on page 4-80.
12. Run engine without radiator cap installed, so that all air will be purged from system. Fill radiator to fill neck.
13. Drain and fill radiator coolant recovery tank.



ARO1760L

Figure 100

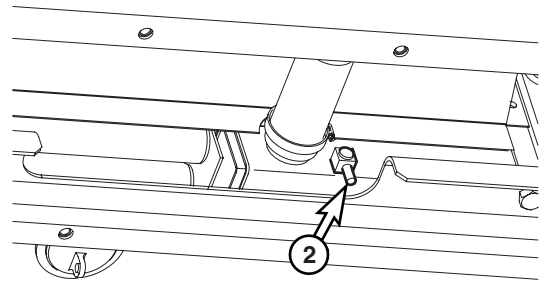

FG001407

Figure 101



ARO1760L

Figure 102

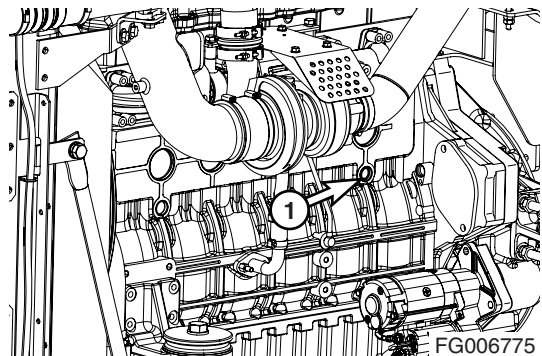

FG006775

Figure 103

## Hydraulic Oil Exchange and Suction Strainer Cleaning

---

### **WARNING!**

---

The hydraulic oil will be hot after normal machine operation. Allow the system to cool before attempting to service any of the hydraulic components.

The hydraulic tank is pressurized. Loosen the breather cap to allow the pressurized air to vent. After the pressure has been released, it is safe to remove either the fill cap or service covers.

---

### **IMPORTANT**

---

Make sure to clean any dirt or water from the top of the hydraulic tank, especially around the fill port and filter ports.

Hydraulic oil change interval is 2,000 hours, only when **DOOSAN** Genuine Oil is used. If another brand of oil is used, guaranteed change interval is 1,000 hours.

---

**NOTE:** *Based on the type of excavating being completed, the working conditions (extremely hot or dusty) and the extra front end attachments being used (hydraulic breaker, etc.), the hydraulic fluid will need to be changed more frequently.*

1. Position the machine on firm, level ground. Swing upper structure perpendicular (90°) to wheels. Lower boom and position bucket on ground as shown in Figure 105.
2. Set safety lever and stand on "LOCK" position.
3. Shut down engine.
4. Release pressurized air from hydraulic tank by rotating breather cap (1, Figure 108).



ARO1760L

Figure 104

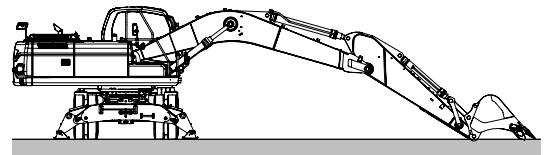

FG008608

Figure 105

5. Drain hydraulic oil from tank into a container capable of holding 200 liters (53 U.S. gal.). After draining tank, install drain plug.

---

## IMPORTANT

---

**Be careful of squirting oil when removing drain plug.**

---

**NOTE:** *Used filter and used oil should always be disposed of according to local regulations.*

6. Carefully remove bolts and cover (2, Figure 108) from top of hydraulic oil tank. There is a spring (3) under the cover that will force the cover up.
7. Remove spring (3, Figure 108) and strainer (5), by pulling on rod (4).
8. Clean inside and outside of strainer. Replace strainer if it is broken.
9. Position strainer (5, Figure 108) on boss portion of suction pipe (6).

**NOTE:** *Measurement "A" is 650 mm (25.59 in).*

10. Fill the hydraulic oil tank. Check level using sight gauge on side of tank.
11. Place spring (3, Figure 108) on rod (4) and assemble cover (2).
12. After replacing and cleaning the hydraulic oil, filter and strainer, vent the system. See "Venting and Priming Hydraulic System" on page 4-91.

---

## IMPORTANT

---

**When the hydraulic breaker is being used, due to the higher heat generated by this unit, use replacement intervals recommended under the "Hydraulic Oil Exchange and Suction Strainer Cleaning" on page 4-56.**

---

13. Check level of hydraulic oil tank. (See page 4-16)

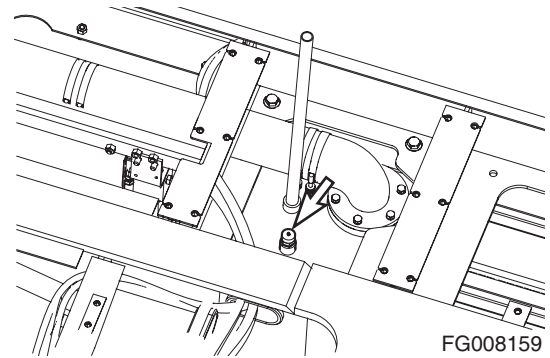

**Figure 106**

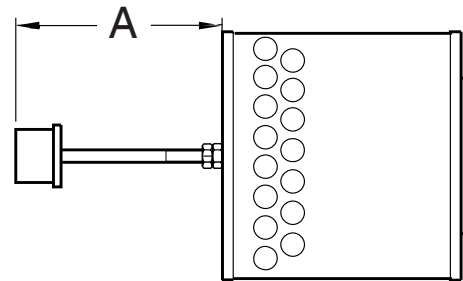

**Figure 107**

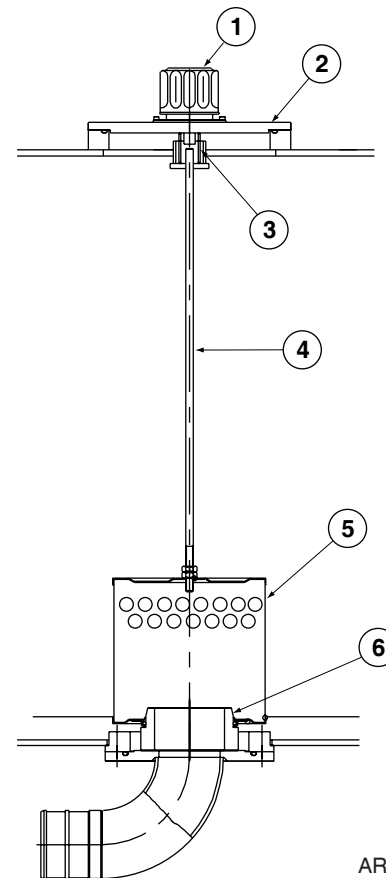

**Figure 108**

## Drain and Refill Transmission Fluid

**NOTE:** The transmission fluid should be drained and refilled after first 500 hours of operation. There after every 2,000 hours of operation.

**NOTE:** The oil level must be checked on level ground. When replacing fluid, only use approved grade transmission fluid.

1. The gear oil drain and fill holes are located on the front lower section of the transmission.
2. Clean off any dirt, grease and other foreign materials from area surrounding the drain (1, Figure 109) and fill (2) holes of the transmission.
3. Place a drain pan under the drain plug and remove the drain plug.
4. Clean the drain plug. Inspect the O-ring for deterioration or damage and replace if necessary. Reinstall drain plug.
5. Remove the fill plug (2, Figure 109) and fill to the bottom of the fill hole with approved transmission fluid.

**NOTE:** See "Fluid Capacities" on page 4-8, for capacity.

6. Clean the fill plug. Inspect the fill plug O-ring for deterioration or damage and replace if necessary. Reinstall the fill plug.

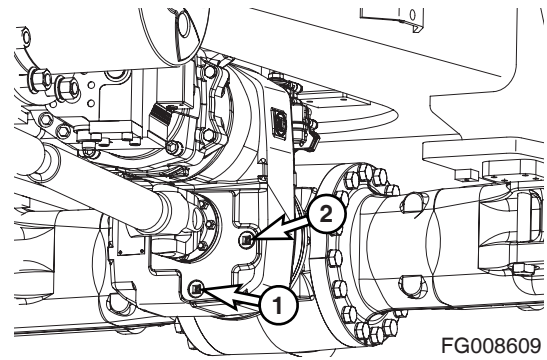

Figure 109

FG008609

## Drain and Refill Front Axle Case Oil

**NOTE:** The front axle case oil should be drained and refilled after the first 500 hours of operation and at every 2,000 hours there after.

**NOTE:** The oil level must be checked on level ground. When replacing fluid, only use approved grade axle fluid.

1. The oil drain (1, Figure 110) and fill (2) holes are located in the front section of the axle case.
2. Clean off any dirt, grease and other foreign materials from area surrounding the drain (1, Figure 110) and fill (2) holes of the axle case.
3. Place a drain pan under the drain plug and remove the drain plug.
4. Clean the drain plug. Inspect the O-ring for deterioration or damage and replace if necessary. Reinstall drain plug.
5. Remove the fill plug (2, Figure 110) and fill to the bottom of the fill hole with approved gear oil.

**NOTE:** See "Fluid Capacities" on page 4-8, for capacity.

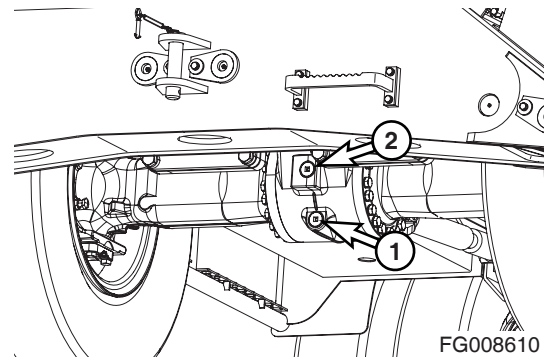

Figure 110

FG008610

- Clean the fill plug. Inspect the fill plug O-ring for deterioration or damage and replace if necessary. Reinstall the fill plug.

## Drain and Refill Rear Axle Case Oil

**NOTE:** *The rear axle case oil should be drained and refilled after the first 500 hours of operation and at every 2,000 hours thereafter.*

**NOTE:** *The oil level must be checked on level ground. When replacing fluid, only use approved grade axle fluid.*

- The oil drain (1, Figure 111) hole is located in the lower section of the axle case and the fill (2) hole is located in the rear section of the rear axle case.
- Clean off any dirt, grease and other foreign materials from area surrounding the drain (1, Figure 111) and fill (2) holes of the axle case.
- Place a drain pan under the drain plug and remove the drain plug.
- Clean the drain plug. Inspect the O-ring for deterioration or damage and replace if necessary. Reinstall drain plug.
- Remove the fill plug (2, Figure 111) and fill to the bottom of the fill hole with approved gear oil.

**NOTE:** *See "Fluid Capacities" on page 4-8, for capacity.*

- Clean the fill plug. Inspect the fill plug O-ring for deterioration or damage and replace if necessary. Reinstall the fill plug.

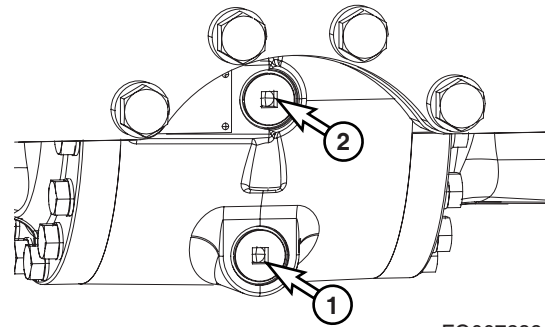

FG007289

**Figure 111**

## Drain and Refill Hub Reduction Gear Oil

**NOTE:** *The hub reduction gear oil should be drained and refilled after the first 500 hours of operation and at every 2,000 hours thereafter.*

**NOTE:** *The oil level must be checked on level ground. When replacing fluid, only use approved grade axle fluid.*

- Move the excavator slowly and position the drain / fill hole to the lowest position.
- Clean off any dirt, grease and other foreign materials from area surrounding the drain / fill (1) hole of the reduction gear.
- Place a drain pan under the drain plug and remove the plug.
- Move the excavator slowly and position the oil level mark (2) on the gear housing parallel to the ground.
- Fill to the bottom of the fill hole with approved gear oil.

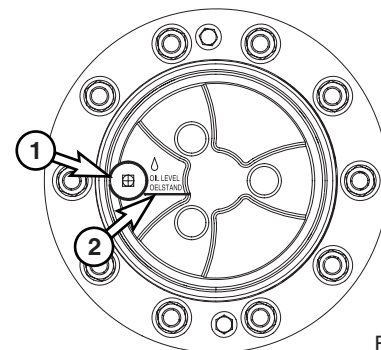

FG003412

**Figure 112**

**NOTE:** See "Fluid Capacities" on page 4-8, for capacity.

6. Clean the drain/fill plug. Inspect the plug O-ring for deterioration or damage and replace if necessary. Reinstall the plug.
7. Repeat the process for the remaining hubs.

## **Check Alternator and Starter\*\***

\*\*These checks need to be completed by an authorized DOOSAN dealer.

## **Check All Rubber Antivibration Shock Mounts**

## **Perform and Record the Results of the Cycle Time Tests**

## **Inspect Machine to Check for Cracked or Broken Welds or other Structural Damage**

## **Check, Adjust Valve Clearance \*\***

## **Check Head Bolt Torques**

# 4,000 HOUR / BIENNIAL SERVICE

## Major Parts - Periodic Replacement

To ensure safe operation and work, perform periodic inspections. Also, to increase safety, replace the following parts. These parts are the ones most often subjected to abrasion, heat and fatigue. Exchange these parts with new ones at the designated time intervals, even if the old parts look good.

Always replace all related parts such as gaskets and O-rings. Use only original equipment manufacturers parts.

Major Component		Parts Name to be Exchanged Periodically	Time to Exchange
Engine		Fuel Hose (Tank to Fuel Prefilter)	2 years or 4,000 hours
		Fuel Hose (Fuel Prefilter to Fuel Cooler)	
		Fuel Hose (Fuel Cooler to ECU)	
		Fuel Hose (Tank to CP Pump)	
		Heater Hose (Heater to Engine)	
		Heater Hose (Heater to Radiator)	
		Air Conditioner Hose	
Hydraulic System	Body	Pump Suction Hose	
		Pump Discharge Hoses	
		Pump Side Branch Hoses	
		Swing Motor Hoses	
		Travel Motor Hoses	
	Work Device	Boom Cylinder Line Hoses	
		Arm Cylinder Line Hoses	
		Bucket Cylinder Line Hoses	
		Option Cylinder Line Hoses	

# 12,000 HOUR / SIX YEAR SERVICE

## Hose In-service Lifetime Limit (European Standard ISO 8331 and EN982 CEN)

European regulations state that the in-service life of any hydraulic hose may not exceed six years. *DOOSAN* recommends the following;

- Hoses at the customer premises can not be stored more than 2 years before being discarded or installed on a machine.
- In-service lifetime of hoses fitted on a machine can never exceed 6 years, but replace hoses described in "Major Parts - Periodic Replacement" on page 4-61, every 2 years. Always replace hoses having exceeded the allowed in-service lifetime irrespective of the external appearance/wear.
- Always store hoses in a dark place at a maximum of 65% relative humidity, between 0°C (32°F) and 35°C (95°F) but as close as possible to 15°C (59°F) and away from copper, manganese or tube generating Ozone.

# AIR-CONDITIONING SYSTEM

**NOTE:** See "Clean Air-Conditioning Outer Filter" on page 4-37.

## Check Control Panel

When a function switch is pushed, the last setting has to be displayed on the LCD display.

When the light switch is turned to "I" position, the LED for illumination in the control panel has to turn "ON."

## Check Air Conditioner Hoses

Check the hose for cracking and damage.



---

When a leak occurs, dirt will accumulate in the area where the leak is. Consult a *DOOSAN* distributor or sales agency.

---

## Check Condenser

Inspect the condenser for dust and debris. Clean if necessary.

**NOTE:** See "Clean Radiator, Oil Cooler, Intercooler, Fuel Cooler and Air Conditioner Condenser Core" on page 4-39.

## Check Magnetic Clutch

Check the magnetic clutch for dirt and interference.

Push the "A/C" switch in order to energize magnetic clutch and check the magnetic clutch.

## Check Belt Tension

**NOTE:** See "Check Engine Fan Belt for Cracks, Wear and Correct Tension" on page 4-31.

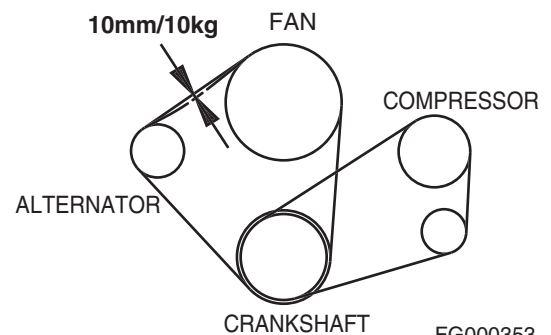

Figure 113

# INSPECTION OF BOLT AND NUT TIGHTENING ELEMENTS

Inspect ALL fasteners after the first 50 hours of operation and every 250 hours thereafter. If any are loose or are missing tighten them or install new hardware. Always use a calibrated torque wrench.

## IMPORTANT

Always clean fasteners before tightening.

If counterweight is loose, contact a *DOOSAN* distributor or sales agent.

No.	Point to be Inspected	Bolt Dia. mm	Qty.	Bolt Head Size	Torque			
					kg•m	N•m	ft lb	
1	Joint Bolt with Engine Mounting Bracket and Engine	Pump Side	16	8	24	27	264	195
		Fan Side	10	8	17	6.5	64	47
2	Joint Bolt & Nut Between Engine Mounting Bracket and Frame	Pump Side	20	2	30	46	451	333
		Fan Side	20	2	30	46	451	333
3	Radiator Mounting Bolt	16	4	24	27	264	195	
4	Tightening Bolt for Hydraulic Oil Tank	16	4	24	27	264	195	
5	Tightening Bolt for Fuel Tank	16	4	24	27	264	195	
6	Tightening Bolt for Pump	10	12	17	6.5	64	47	
7	Tightening Bolt for Control Valve	12	4	19	11	108	80	
8	Tightening Bolt for Swing Reduction Device	20	11	30	55	539	398	
9	Tightening Bolt for Swing Motor	12	16	10	14.4	141	104	
10	Tightening Bolt for Battery	10	2	17	6.5	64	47	
11	Joint Bolt with Cab Mounting Rubber and Frame	10	20	17	6.5	64	47	
	Joint Bolt with Cab Mounting Rubber and Cab	16	3	24	21	206	152	
12	Joint Bolt with Swing Bearing and Upper Frame	20	36	30	55	539	398	
	Joint Bolt with Swing Bearing and Bottom Frame	20	36	30	55	539	398	
13	Tightening Bolt for Rear Axle	24	8	36	95	929	686	
14	Tightening Bolt for Propeller Shaft	10	32	14	7	69	51	
15	Tightening Bolt for Travel Motor	16	4	14	27	265	195	
16	Tightening Bolt for Ram Cylinder	24	4	20	95	929	686	
17	Tightening Bolt for Center Joint	12	4	19	11	108	80	
18	Tire Wheel Nut	22	40	32	55~60	539~588	400~434	
19	Front Pin Mounting Bolt	16	9	24	27	265	195	
20	Breaker Filter (Optional)	12	4	19	11	108	80	
21	Tightening Bolt for Lower Attachment	Front	24	14	36	95	929	686
		Rear	24	20	36	95	929	686

1. Joint Bolt with Engine Mounting Bracket and Engine

1) Pump Side

- Tool : 24 mm (  )
- Torque : 27 kg•m

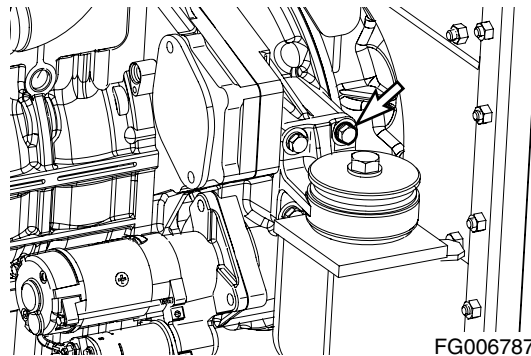



Figure 114

2) Fan Side

- Tool : 17 mm (  )
- Torque : 6.5 kg•m

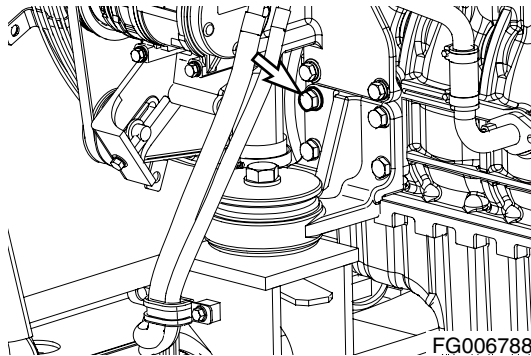



Figure 115

2. Joint Bolt & Nut Between Engine Mounting Bracket and Frame

1) Pump Side

- Tool : 30 mm (  )
- Torque : 46 kg•m

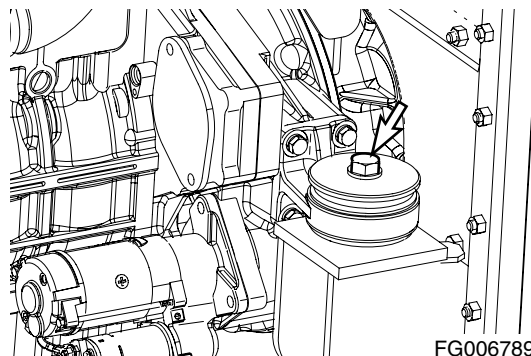



Figure 116

2) Fan Side

- Tool : 30 mm (  )
- Torque : 46 kg•m

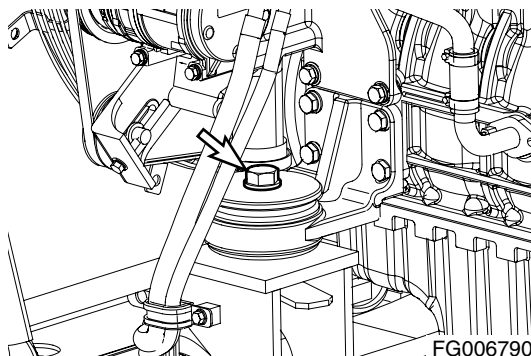



Figure 117

3. Radiator Mounting Bolt

- Tool : 24 mm (  )
- Torque : 27 kg•m

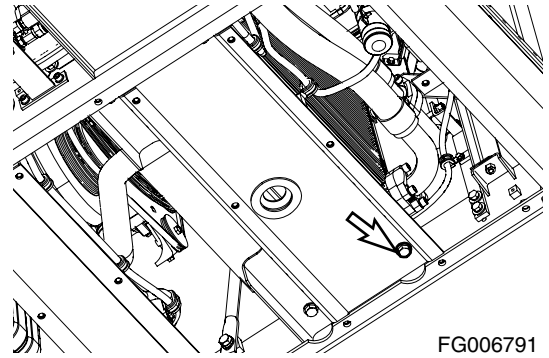



Figure 118

FG006791

4. Tightening Bolt for Hydraulic Oil Tank

- Tool : 24 mm (  )
- Torque : 27 kg•m

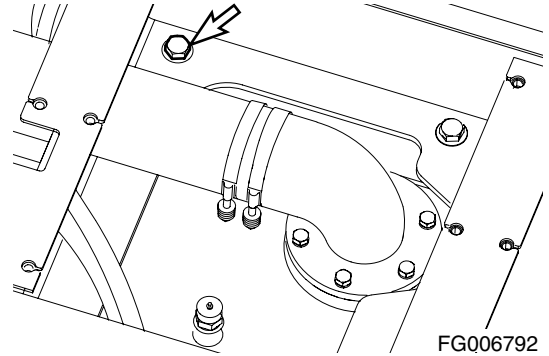



Figure 119

FG006792

5. Tightening Bolt for Fuel Tank

- Tool : 24 mm (  )
- Torque : 27 kg•m

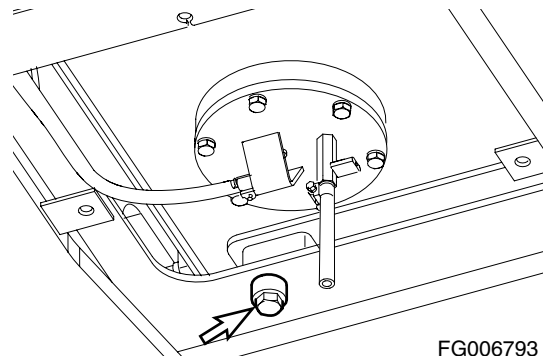



Figure 120

FG006793

6. Tightening Bolt for Pump

- Tool : 17 mm (  )
- Torque : 6.5 kg•m

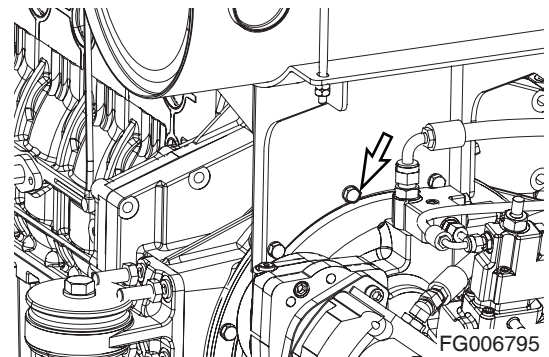



Figure 121

FG006795

7. Tightening Bolt for Control Valve

- Tool : 19 mm (  )
- Torque : 11 kg•m

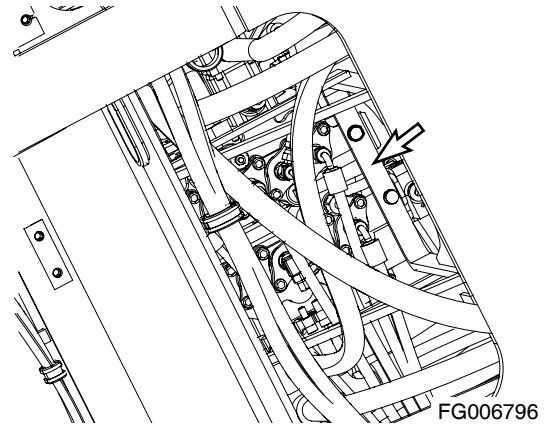



Figure 122

8. Tightening Bolt for Swing Reduction Device

- Tool : 30 mm (  )
- Torque : 35 kg•m

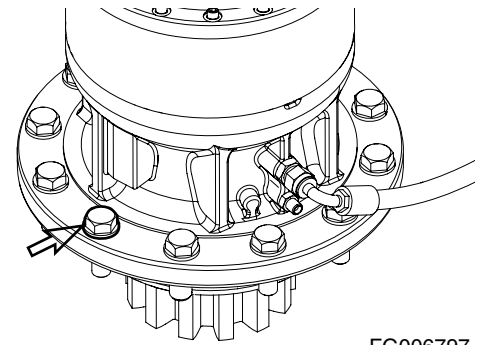



Figure 123

9. Tightening Bolt for Swing Motor

- Tool : 10 mm (  )
- Torque : 14.4 kg•m

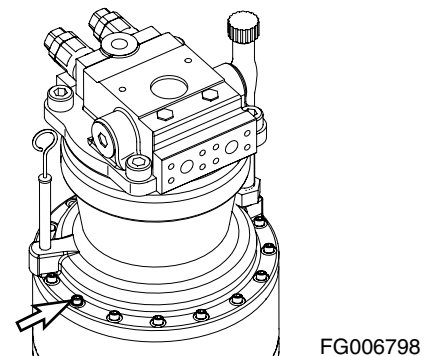



Figure 124

10. Tightening Bolt for Battery

- Tool : 17 mm (  )
- Torque : 6.5 kg•m

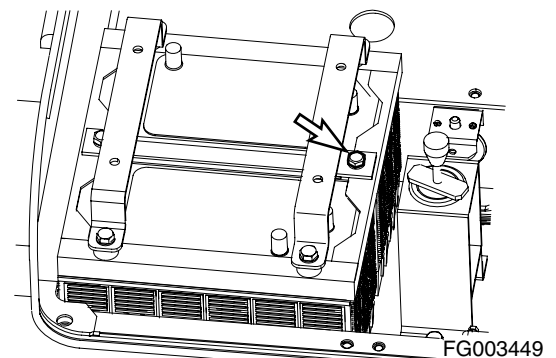



Figure 125

11. Joint Bolt with Cab Mounting Rubber and Frame

- Tool : 17 mm (  )
- Torque : 6.5 kg•m

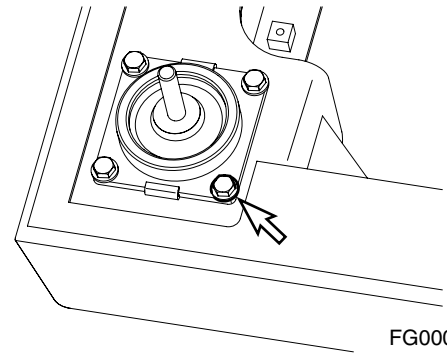



Figure 126

Joint Bolt with Cab Mounting Rubber and Cab

- Tool : 24 mm (  )
- Torque : 21 kg•m

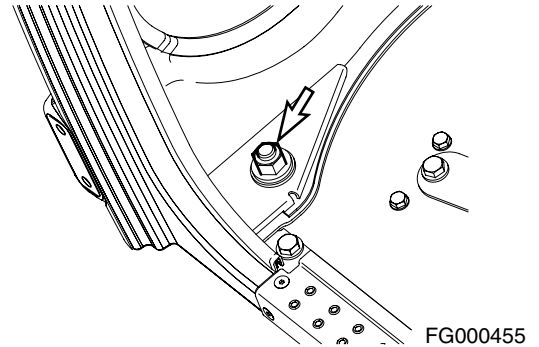

Figure 127

12. Joint Bolt with Swing Bearing and Upper Frame



- Tool : 30 mm (  )
- Torque : 55 kg•m



Figure 128

Joint Bolt with Swing Bearing and Bottom Frame

- Tool : 30 mm (  )
- Torque : 55 kg•m

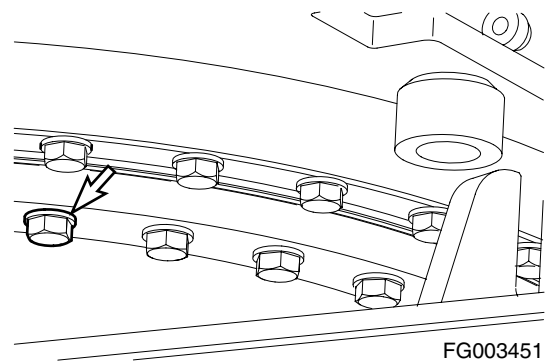

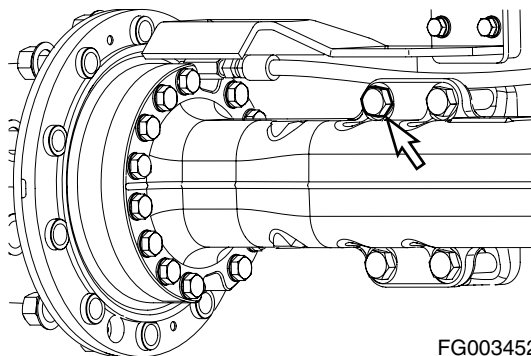

Figure 129

13. Tightening Bolt for Rear Axle

- Tool : 36 mm (  )
- Torque : 95 kg•m



FG003452

Figure 130

14. Tightening Bolt for Propeller Shaft

- Tool : 14 mm (  )
- Torque : 7 kg•m

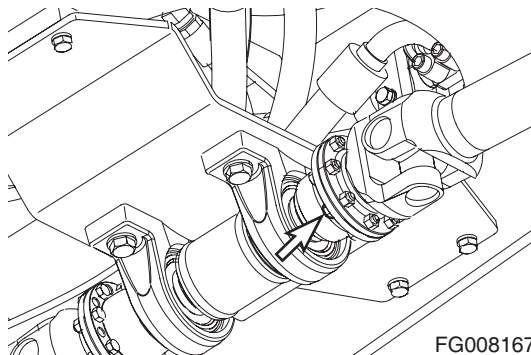

FG008167

Figure 131

15. Tightening Bolt for Travel Motor

- Tool : 14 mm (  )
- Torque : 27 kg•m

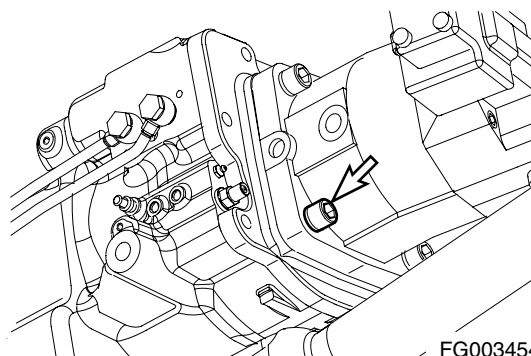

FG003454

Figure 132

16. Tightening Bolt for Ram Cylinder

- Tool : 20 mm (  )
- Torque : 95 kg•m

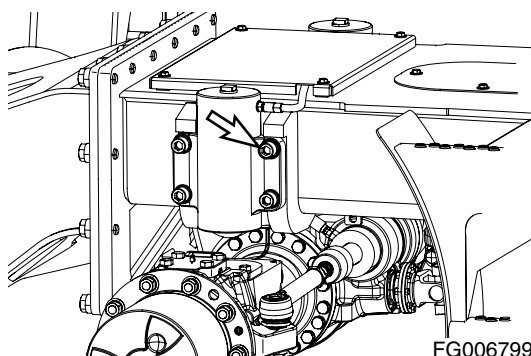

FG006799

Figure 133

17. Tightening Bolt for Center Joint

- Tool : 19 mm (  )
- Torque : 11 kg•m

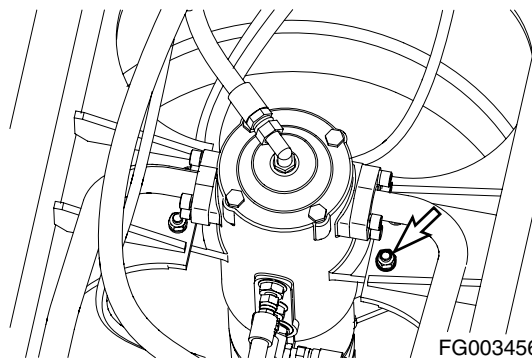



Figure 134

FG003456

18. Tire Wheel Nut

- Tool : 32 mm (  )
- Torque : 55 ~ 60 kg•m

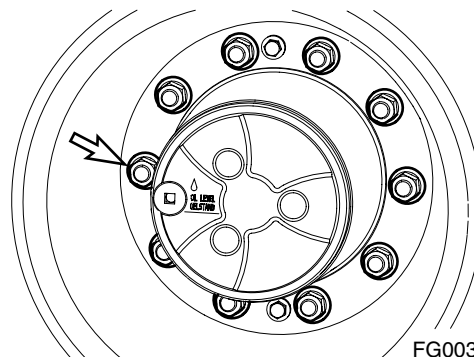



Figure 135

FG003457

19. Front Pin Mounting Bolt

- Tool : 24 mm (  )
- Torque : 27 kg•m

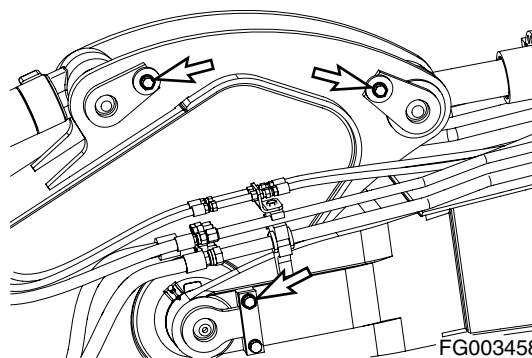



Figure 136

FG003458

20. Breaker Filter (Optional)

- Tool : 19 mm (  )
- Torque : 11 kg•m

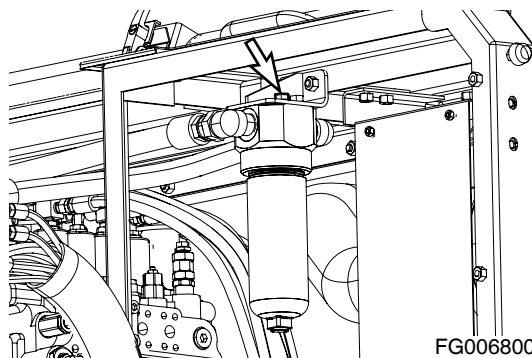



Figure 137

FG006800

## 21. Tightening Bolt for Lower Attachment

### 1) Front

- Tool : 36 mm (  )
- Torque : 95 kg•m

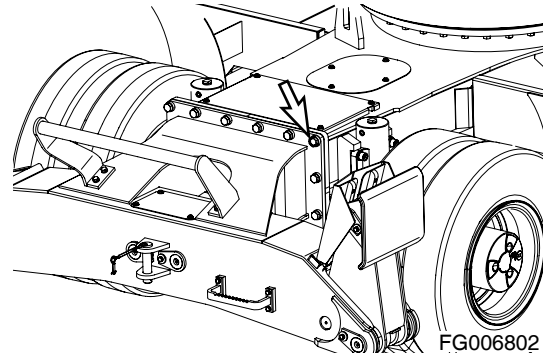

**Figure 138** Front Attach

### 2) Rear

- Tool : 36 mm (  )
- Torque : 95 kg•m

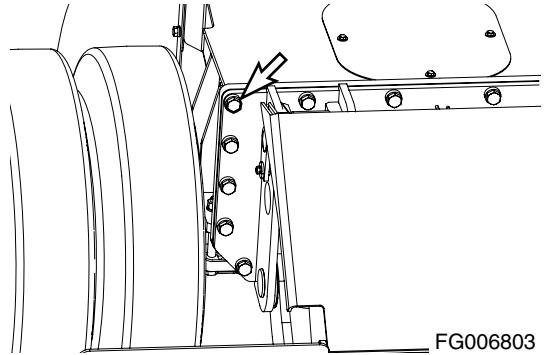

**Figure 139** Rear Attach

# BUCKET

## Bucket Tooth Replacement



### WARNING!

Due to the possibility of flying metal objects, always wear safety helmet, protective gloves and eye protection when changing bucket teeth.

Curl the bucket upwards and place the round rear surface of the bucket firmly on the ground. Shut the engine off and lock out the hydraulic controls before working on the bucket.

**NOTE:** *These instructions are only for DOOSAN OEM buckets. If you are using other manufacturers buckets, refer to their specific instructions.*

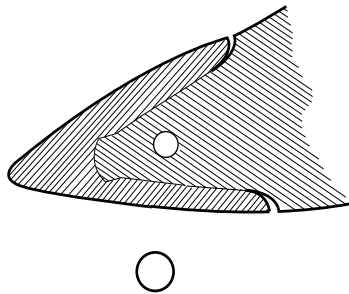
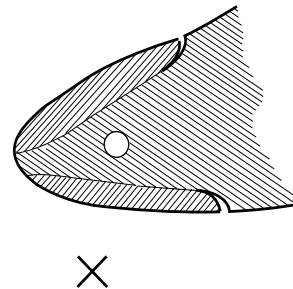
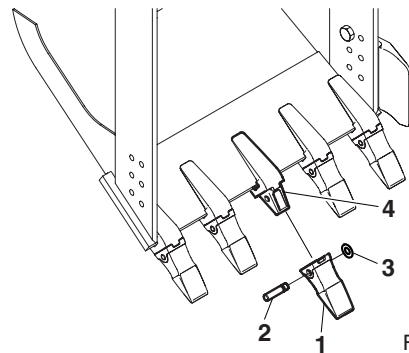

Figure 140



HAOC680L

1. On a routine basis, inspect bucket teeth to make sure that tooth wear or breakage has not developed. Do not allow replaceable bucket teeth to wear down to a point that bucket adapter is exposed. See Figure 140.
2. To replace a tooth (1, Figure 141), use a hammer and punch to drive locking pin (2) and lock washer (3) out of tooth adapter (4).
3. Once worn tooth has been removed, use a putty knife to scrape adapter as clean as possible.
4. Slide new tooth into position and insert lock washer.
5. Insert locking pin into tooth and with a hammer, drive pin in until lock washer seats in locking groove.



FG000346

Figure 141

# Bucket O-ring Replacement

## **WARNING!**

Due to possibility of flying metal objects, always wear safety helmet, protective gloves and eye protection when changing pins.

1. Inspect bucket O-rings on a routine basis. If worn or damaged, replacement is necessary.

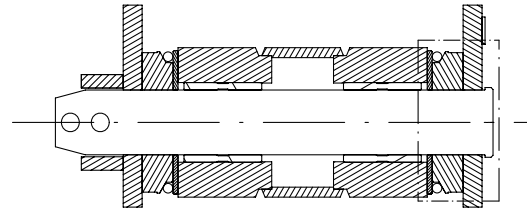

FG006427

**Figure 142**

2. Roll old O-ring (1, Figure 143) onto boss (2) around bucket pin (3). Remove bucket pin and move arm or bucket link (4) out of way.

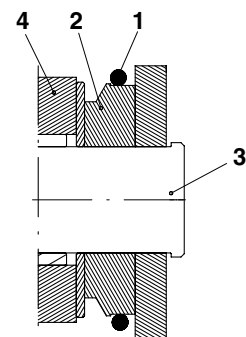

FG006428

**Figure 143**

3. Remove old O-ring and temporarily install new O-ring (1, Figure 144) onto bucket boss (2). Make sure that O-ring groove on both bucket link (4) and boss have been cleaned.
4. Realign arm or link with bucket pin hole and insert bucket pin (3, Figure 143).

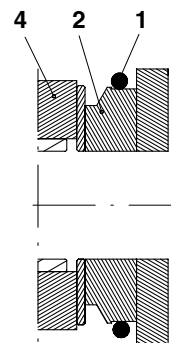

FG006429

**Figure 144**

5. Roll new O-ring (1, Figure 145) into O-ring groove.

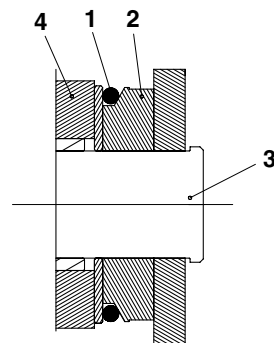

FG006430

Figure 145

# ELECTRICAL SYSTEM

**NOTE:** *Never disassemble electrical or electronic parts. Consult with a DOOSAN distributor or sales agency before servicing.*

## Battery

---



### **WARNING!**

---

Battery electrolyte contains sulfuric acid and can quickly burn the skin and eat holes in clothing. If you spill acid on yourself, immediately flush the area with water.

Battery acid could cause blindness if splashed into the eyes. If acid gets into the eyes, flush them immediately with large quantities of water and see a doctor at once.

If you accidentally drink acid, drink a large quantity of water or milk, beaten egg or vegetable oil. Call a doctor or poison prevention center immediately.

When working with batteries, always wear safety glasses or goggles.

Battery generates hydrogen gas, so there is danger of an explosion. Do not bring lighted cigarettes near the battery, or do anything that will cause sparks.

Before working with batteries, shut down engine and turn the starter switch to the "O" (OFF) position.

Avoid short circuiting the battery terminals through accidental contact with metallic objects, such as tool.

When removing or installing, check which is the positive (+) terminal and negative (-) terminal.

When removing the battery, first disconnect the negative (-) terminal. When installing the battery, first connect the positive (+) terminal.

If the terminals are loose, there is danger that the defective contact may generate sparks that will cause an explosion. When installing the terminals, install them tightly.

---

### **Batteries in Cold Weather**

In colder weather a greater drain is placed on the batteries when they are used for the preheat cycle and when starting a cold engine. Battery performance decreases as the temperature gets lower.

In extremely cold weather, remove the batteries at night and move them to a warm location. This will help to keep them at a higher power level.

## Inspection of Battery Electrolyte Level

This machine has two maintenance free batteries. They never require the addition to water.

When the charge indicator becomes transparency, it means low electrolyte state because of the leakage or charging system error. Determine the cause of problem and replace the batteries immediately.

## Check Charging State

Check charging state through the charging indicator.

- GREEN: Sufficiently charged.
- BLACK: Insufficient charged.
- TRANSPARENT: Replace battery.

## Check the Battery Terminals

Be certain that the battery is held securely in its compartment. Clean the battery terminals and the battery cable connectors. A solution of baking soda and water will neutralize acid on the battery surface, terminals, and cable connectors. Petroleum jelly or grease can be applied to the connectors to help prevent corrosion.

## Battery Replacement

When the charging indicator indicates transparency state, replace the battery. The batteries should always be replaced in pairs.

Using an old battery with a new one will shorten the life span of the new battery.

## Fuses

1. The fuses in the fuse box are used to protect the various electrical circuits and their components from being damaged. See Figure 148. The fuses used are standard automotive type fuses.
2. The section on "Fuse Identification" on page 4-78, lists the circuits and the fuse amperage required for each circuit. If a fuse blows, determine the cause and repair any faults or failures.
3. Do not insert a higher amperage fuse into a lower amperage slot. Serious damage to the electrical components or fire can result.

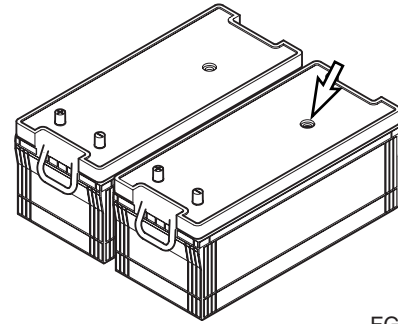

FG000347

Figure 146

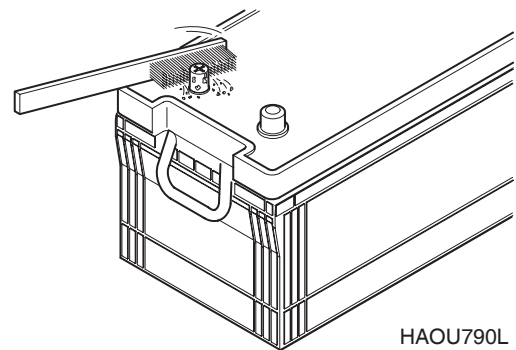

HAOU790L

Figure 147

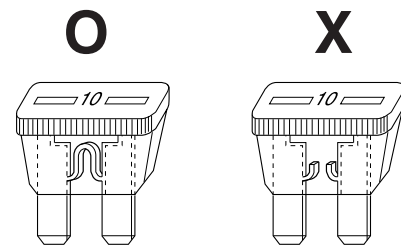

HAOC670L

Figure 148

---

**⚠ CAUTION!**

---

**Before replacing a fuse, be sure to turn starter switch to "O" (OFF) position.**

---

**Fuse Boxes**

There are two fuse boxes (Figure 149) on the left side of the heater box. The fuses prevent electrical devices from overloading or shorting.

A decal attached to the inside of the fuse box's cover indicates the function and amperage of each fuse.

Spare fuses are mounted on the inside of fuse box's cover. (One each of a 10A, 15A, 20A and 30A.)

Change a fuse if the element separates. If the element of a new fuse separates, check the circuit and repair the circuit.

---

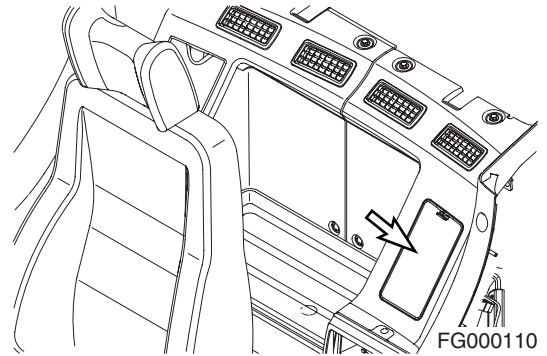

**Figure 149**

---

**⚠ CAUTION!**

---

**Always replace fuses with the same type and capacity fuse that was removed. Otherwise, electrical damage could result.**

---

## Fuse Identification

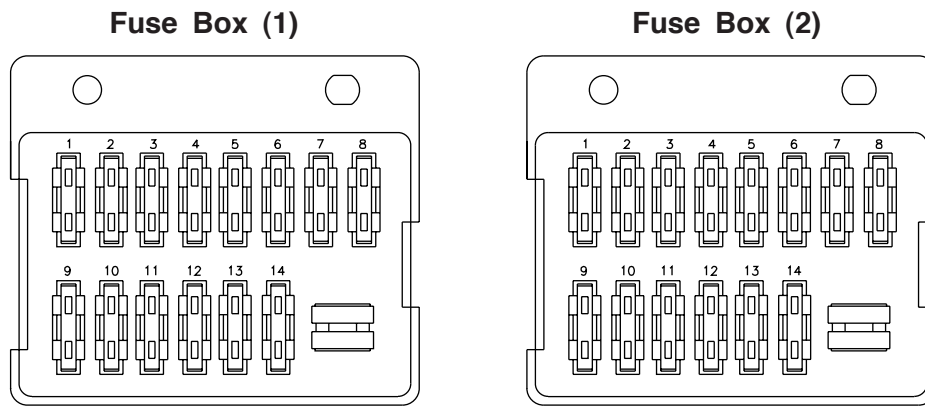

FG009158

Figure 146

No.	Fuse Box (1)	
	Name	Capacity
1	Transmission Lever	10A
2	Reverse Solenoid	10A
3	Forward/Cruise Solenoid	10A
4	Pilot Cut Off/Ram Lock/ Inching/Hi/Low Solenoid	10A
5	Forward/Reverse/Cruise Switch	10A
6	Beacon (Option) 12v Power Socket	10A
7	Room Lamp/Hazard/Position Lamp/Turn Signal Lamp	10A
8	Starter Switch/Hour Meter	10A
9	Head Lamp	30A
10	Airconditioner/Heater	20A
11	Fuel Heater	20A
12	Seat Heater (Option)/ Air Suspension (Option)	15A
13	Window Washer/Low Wiper (Option)	15A
14	Fuel Pump/Stereo/Memory Backup	15A

No.	Fuse Box (2)	
	Name	Capacity
1	Gauge Panel/Press. Sensor	10A
2	Aux. Mode Switch/Check Connector	10A
3	Working Lamp	10A
4	Stop Lamp	10A
5	Quick Clamp (Option)/ Breaker (Option)	10A
6	Horn	10A
7	Position Lamp (LH)	10A
8	Position Lamp (RH)	10A
9	Cabin Lamp (Option)	30A
10	Spare	20A
11	e-EPOS Controller	20A
12	Swing Priority Sol./Outrigger	15A
13	Power Max/Cigar Lighter	15A
14	ECU	15A

# ENGINE COOLING SYSTEM

## General

Keeping an engine's cooling system in peak operating condition, can have many benefits to keeping a machine in good operating condition. A properly functioning cooling system will; improve fuel efficiency, reduce engine wear, and extend component life.

Always use distilled water in the radiator. Contaminants in tap water neutralize the corrosion inhibitor components. If tap water must be used, it should not exceed 300 ppm hardness, or contain more than 100 ppm of either chloride or sulfate. Water that has been treated with a water softener also contains salt that will cause corrosion of components. Water from creeks and stagnant pools usually contains dirt, minerals and/or organic material that are deposited in the cooling system and impair cooling efficiency. Distilled water is the best.

Engine overheating is often caused by bent or clogged radiator fins. The spaces between the fins can be cleaned by use of air or water under pressure. When straightening bent fins, use care not to damage the tubes or break the bond between the fins and the tubes.



## **WARNING!**

---

**Pressure at air nozzle must not exceed 30 PSI (2.1 kg/cm<sup>2</sup>).  
Always wear goggles when using compressed air.**

**Do not pour cold water into radiator when engine is very hot and water level is below the top of the tubes. Such action could result in damage to engine cylinder heads.**

---

Heavy duty diesel engines require a balanced mixture of water and antifreeze. Drain and replace the mixture every year or 2,000 hours of operation, whichever ever comes first. This will eliminate buildup of harmful chemicals.

Antifreeze is essential in any climate. It broadens the operating temperature range by lowering the coolant's freezing point and by raising its boiling point. Do not use more than 50% antifreeze in the mixture unless additional freeze protection is required. Never use more than 68% antifreeze under any condition.

## Types of Antifreeze

There are two main classifications of antifreeze available on the market today.

1. Ethylene Glycol - Standard Life Antifreeze
2. Propylene Glycol - Extended Life Antifreeze

Ethylene glycol (standard life antifreeze) has been on the market for many years. Its chemical properties do not provide the improved corrosion resistance that propylene glycol (extended life antifreeze) does. Ethylene glycol is also very hazardous to the environment, people and animals. *DOOSAN* recommends that ethylene glycol be replaced with propylene glycol.

The newer propylene glycol antifreeze comes in many different colors. Some of the colors are pink, red, orange and yellow. There are even some that come in a blue-green color. The blue-green color makes it very difficult to tell the difference of what type of antifreeze is in a cooling system. The colors are only a dye added to the clear antifreeze. Do not rely on color. Keep careful machine records of what brand and type of antifreeze is used in the unit. If you are unsure of what type of antifreeze is in the system, drain and flush the system.

**NOTE:** *Do not mix ethylene glycol and propylene glycol antifreeze together. If the two are mixed, the protection level will be reduced to the level of the ethylene glycol.*

## Antifreeze Concentration Tables

Ethylene Glycol - Standard Life Antifreeze (1,000 Hour / 6 Months)		
Ambient Temperature	Cooling Water	Antifreeze
-10°C (14°F)	80%	20%
-15°C (5°F)	73%	27%
-20°C (-4°F)	67%	33%
-25°C (-13°F)	60%	40%
-30°C (-22°F)	56%	44%
-40°C (-40°F)	50%	50%

Propylene Glycol - Extended Life Antifreeze (2,000 Hour / Yearly)		
Ambient Temperature	Cooling Water	Antifreeze
-10°C (14°F)	78%	22%
-15°C (5°F)	71%	29%
-20°C (-4°F)	65%	35%
-25°C (-13°F)	59%	41%
-30°C (-22°F)	55%	45%
-40°C (-40°F)	48%	52%

# FUEL TRANSFER PUMP (OPTION)

---

## **WARNING!**

---

Do not dry operate fuel pump for more than fifteen seconds.

- Cooling and lubrication of pump is achieved by fuel passing through pump. If pump is dry operated, heat generated by moving parts will cause damage to pump rotors, vanes and seals. To prevent unnecessary wear and/or damage to pump do not dry operate fuel pump for more than fifteen seconds.

Do not operate pump for more than fifteen minutes at a time.

- Continuous usage of pump over recommended time interval will cause overheating of motor and will result in causing motor damage.

Do not use refueling pump for other types of fuel or fluids.  
(Use only for diesel fuel.)

- Do not use refueling pump for other types of fuel which have a low flash point.
- Do not use refueling pump for fuel contaminated with water or high humidity. Moisture in pump mechanism can cause rust and can create pump failure.

Always operate pump using strainer installed on inlet hose. This will prevent any foreign materials from being introduced into pump. Always maintain pump and all of its components in a clean condition.

- If dirt or other foreign materials enter pump, it can become lodged between the rotor and/or vanes and generate heat which can cause pump damage.
- Do not remove strainer or use a strainer with larger mesh to increase flow of fuel.

Be careful not to overfill or spill fuel.

Make sure direction of check valve is in line with flow direction of fuel.

If any pump parts or components become lost, damaged or inoperable, immediately replace it with a new ones.

---

# IMPORTANT

If there are any sign of leakage while operating transfer pump, inspect the following components to prevent any fires or hazardous fuel spills.

- Check all hoses leading to and from the transfer pump.
- Check all hose clamps.
- Check transfer pump inlet port.

The transfer pump is used to transfer fuel from a refueling source to the fuel tank. A check valve is installed in the inlet hose to prevent fuel from flowing back from fuel tank to source. A strainer is installed in inlet hose to prevent any foreign material from being introduced into transfer pump or fuel tank.

A thermal limiter, built into the motor, will automatically shut off power if motor is overheating to protect it from being damaged.

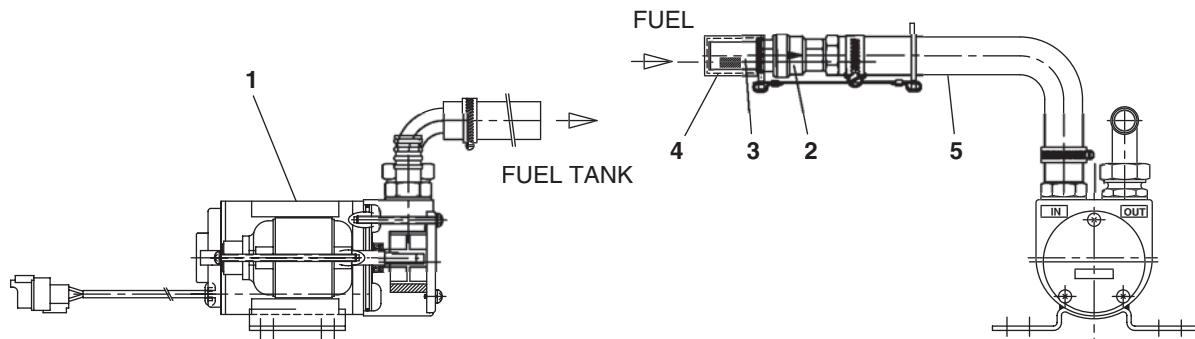

FG000161

Figure 151

Reference Number	Description
1	Body
2	Check Valve
3	Strainer

Reference Number	Description
4	Strainer Cap
5	Inlet Hose

1. Remove strainer cap (4, Figure 151) from strainer (3) on end of inlet hose (5).

**NOTE:** *Keep strainer cap (4, Figure 151) in a safe location to reseal strainer (3) after refueling is complete.*

2. Insert inlet hose (5, Figure 151) into refueling tank.
3. Turn fuel pump switch (Figure 152) inside of battery box on front side to "I" (ON) position.

**NOTE:** *Transfer pump rate of flow is approximately 35 liters/minute (9.24 U.S. gpm). Use extra care not to overfill fuel tank so that fuel does not overflow.*

4. Once fuel transfer is completed, immediately turn switch to "O" (OFF) position to stop pump.
5. Lift inlet hose (5, Figure 151) from fueling source and turn switch to "I" (ON) position for two - three seconds to drain remaining fuel from hose to fuel tank.
6. Install strainer cap (4, Figure 151) on inlet strainer (3) and return hose (5) to storage position.

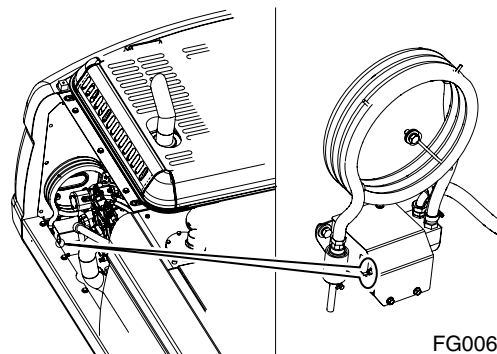

**Figure 152**

FG006783

# HANDLING OF ACCUMULATOR

---

## **WARNING!**

Even though the engine or pump is stopped, the hydraulic accumulators for the pilot and brake system are still charged. Do not disconnect any pilot and brake system hoses until accumulator pressure has been released from the circuit. To release pressure, turn the starter switch to the "I" (ON) position and operate all hydraulic control levers and press the service brake pedal. Even though the engine is shutdown hydraulic actuated components may move while releasing pilot pressure and emergency brake is applied during pressing service brake pedal. Keep all personnel away from excavator while performing this operation.

- Set safety lever and stand on "LOCK" position after stopping engine.
- DO NOT mishandle accumulator(s). They are very dangerous because they contain high-pressure nitrogen gas.
- DO NOT punch a hole or apply heat or fire to an accumulator.
- DO NOT weld on accumulator, or try attaching anything to it.
- When replacing an accumulator, contact a *DOOSAN* distributor or sales agency so the gas can be properly released.
- Wear safety goggles and protective gloves when working on an accumulator. Hydraulic oil under pressure can penetrate the skin and cause serious injuries.

---

## Pilot Accumulator

Release pilot accumulator pressure using the following procedure;

1. Position the machine on firm, level ground. Lower the front attachment to the ground and shut down engine.
2. Set safety lever and stand on "RELEASED" position.
3. Turn starter switch to the "I" (ON) position.
4. Fully stroke work in all directions.
5. Set safety lever and stand on "LOCK" position.
6. Turn key to "O" (OFF) position and remove from starter switch.
7. Remove accumulator by unscrewing it slowly.

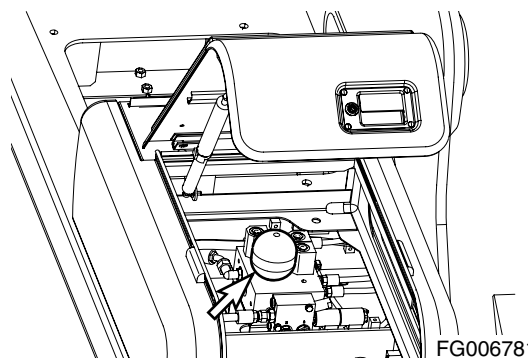

Figure 153

FG006781

# Brake Accumulator

## Release Brake Accumulator Pressure

Using the following procedure;

1. Position the machine on firm, level ground.  
Lower the front attachment to the ground.
2. Set parking brake switch to the "I" position.  
This will ensure that the parking brake is "APPLIED".
3. Set safety lever and stand on "LOCK" position.
4. Shut down engine.
5. Wheel chock is installed under the tires to secure the machine.
6. Release the brake line pressure by stepping on the service brake pedal several times.
7. Open the left door of the machine.
8. Remove accumulator by unscrewing it slowly.

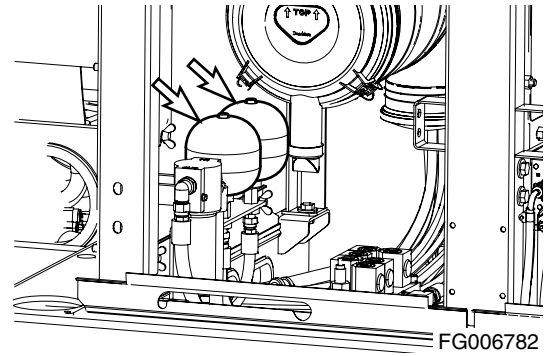

**Figure 154**

# TIRES AND WHEELS

Properly inflated tire (2, Figure 155) is an important factor in determining tire performance and tire life. A tire that is under inflated (1, Figure 155) does not properly support machine, and will wear out quickly. Overinflated tires (3, Figure 155) have poor traction and puncture easily.

Use a pressure gauge to measure tire pressure. Always measure tire pressure before machine has been working, when tires are cold. Use table below to determine correct pressure for front or rear tires when driving machine, or when working machine.

Check tires for damage and embedded objects. Check valve stems for damage.

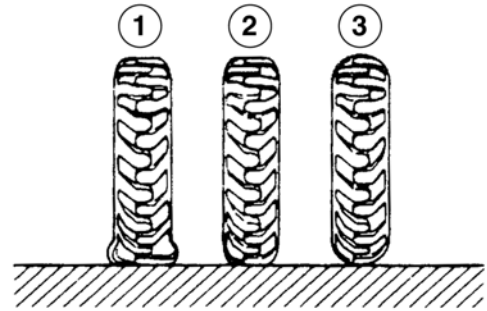

Figure 155

HCB3049S

Tire Dimension	Working Pressure		Remarks
	Front Tire	Rear Tire	
10.00-20-14PR	6.75 - 7.0 kg/cm <sup>2</sup> (96 - 100 psi)	6.75 - 7.0 kg/cm <sup>2</sup> (96 - 100 psi)	Standard

## Check Tire for Damage

---

### **WARNING!**

Improper servicing or changing tires and rims can cause explosion resulting in serious injury or death.

Do not service or change tires and rims unless properly trained and equipped.

Contact your nearest *DOOSAN* loader dealer or tire manufacturer's local dealer for tire servicing or changing.

---

### **WARNING!**

Overheated tire may explode causing serious injury or death.

If overheated tire is suspected, do not approach tire to distance of less than 15 m (50 ft).

Stay away until tire and rim cool down.

---

If the following defects are found in tires, for safety reasons the tires should be replaced with new tires.

For the replacement contact *DOOSAN* loader dealer or a tire manufacturer's local dealer.

- Bead wire is broken or bent, or the tire is greatly deformed.
- Wear is excessive and the carcass ply (including breaker) is exposed for more than 1/4 of the circumference.
- Damage to the carcass exceeds 1/3 of the tire width.
- Tire layers are separated.
- Radial cracks reach the carcass.
- Deformation or damage which makes the tire unsuitable for use.

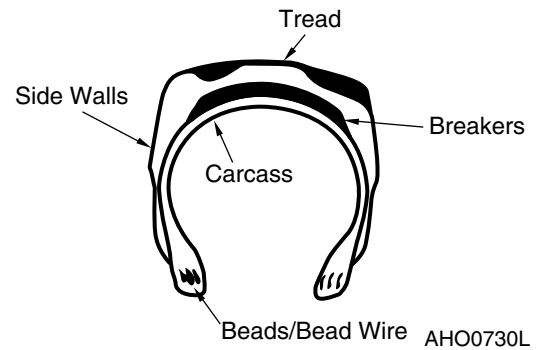

Figure 156

AH00730L

## Tire Changing Procedure



1. Before changing tires, move pilot cutoff switch to "LOCKED" position. Place a warning tag on controls so that no one begins to operate machine while tires are being changed.
2. Lower outriggers (if so equipped) and secure machine.
3. Secure other tires not being changed by using wheel chocks.

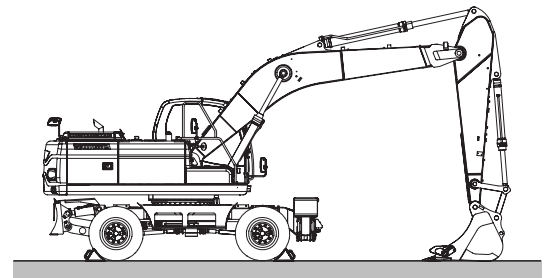

Figure 157

FG006784

When mounting tires, be certain that tires are mounted with direction of rotation mark facing in proper direction. If no rotation direction arrow is visible, examine tread marks and position them to face the front of machine for proper traction and wear.

**NOTE:** *Unmatched tires will cause uneven wear and put unnecessary load on the final drive. Use recommended, matched tires for proper wear and performance.*



Figure 158

HAOM290L

1. Park machine on secure and level ground able to support weight of machine.
2. Using a jack rated for weight of machine, raise machine to a height so that tires have enough clearance. Place appropriate stands under frame to support machine.
3. Lower bucket to ground.

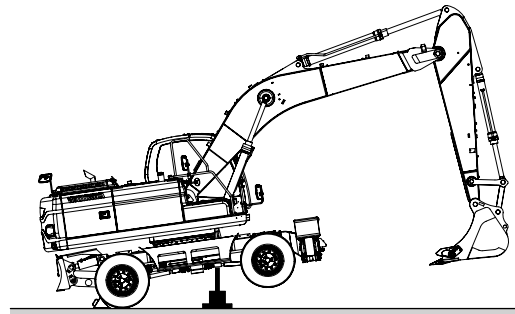

FG006785

Figure 159

4. Tire assembly cross section view

**NOTE:** Rubber spacer protrusion part shall face inner tire rim side.

Reference Number	Description
1	Wheel Nut
2	Outer Tire Rim
3	Rubber Spacer
4	Inner Tire Rim
5	Outer and Inner Tire Assembly Bolt
6	Outer and Inner Tire Assembly Nut
7	Outer and Inner Tire Assembly Washer

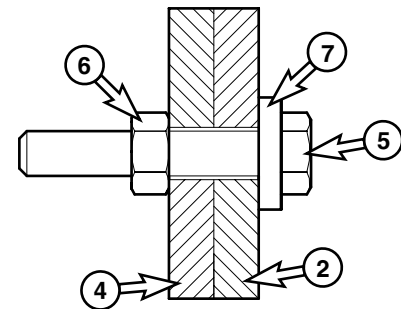
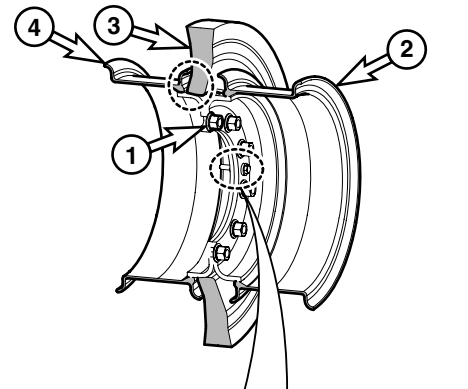

## CAUTION!

When assembling tire, you should only assemble after checking the assembling direction position of each assembling bolt, nut and washer.

FG003431

Figure 160

5. Remove tire set (outer and inner tires) (2) out of axle hub (3) after releasing wheel nut (1) by means of wheel wrench.

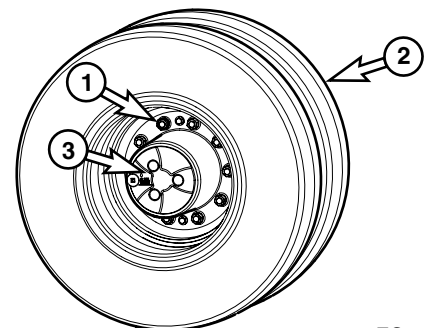

FG003432

Figure 161

- Place the tire set (outer and inner tires) on flat ground surface and remove outer and inner tire assembly bolts(4).

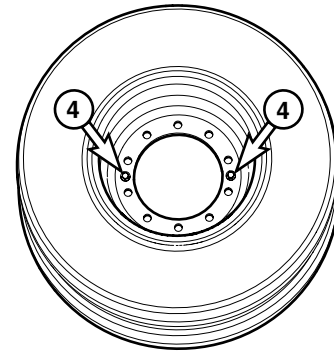

FG003433

Figure 162

- Remove rubber spacer (5) and check any damage of all parts so as to replace part to a new one if there are wear and damage.

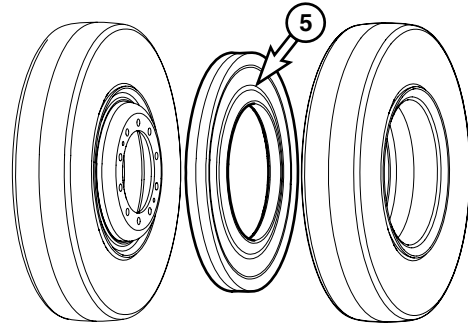

FG003434

Figure 163

- As for sequential order of assembling the tire, firstly place inner tire on flat ground surface, and then lay it so that rubber spacer come to central part of inner tire upon inner tire ring.

**NOTE:** Assemble so that rubber spacer protrusion part shall face inner tire rim side.

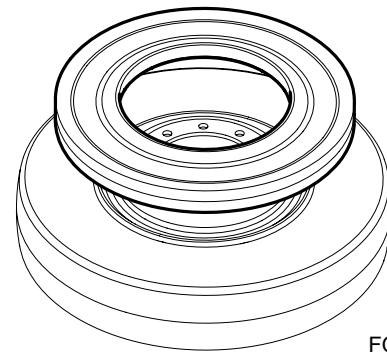

FG003435

Figure 164

- Place outer tire on rubber spacer while taking heed to outer and inner tire assembly bolt holes; and then fasten tire assembly bolt (4) (tightening torque of 11 Kg•m).



## CAUTION!

Assemble after checking the assembling direction position of each assembling bolt, nut and washer.

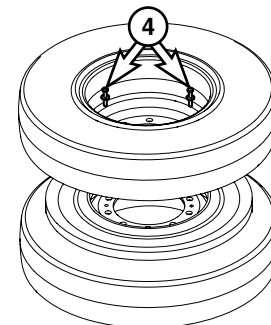

FG003436

Figure 165

10. Assemble tire set (outer and inner tires) to axle hub (3) while taking heed to assembly bolt holes (6). Whence take care so that tire assembly bolt (4) may not be damaged by axle hub (3).

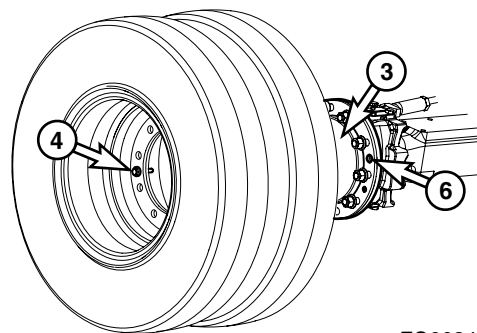

FG003437

**Figure 166**

11. Follow tightening pattern (Figure 167) when tightening wheel nuts. Tighten to specified torque. (Tightening torque 55 - 60 kg•m).

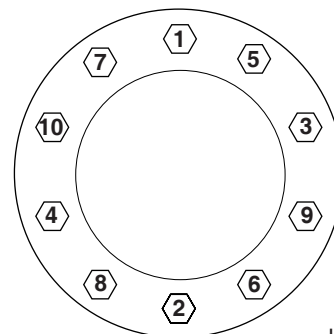

HAOM310L

**Figure 167**

12. Run machine forward and backward several times to ensure proper assembly and seating of the washers. Retighten wheel nuts to ensure proper torque. (torque 55 ~ 60 Kg•m).
13. Once again tighten tire assembly bolts (4) (tightening torque 11 Kg•m) after completion of wheel nut tightening.

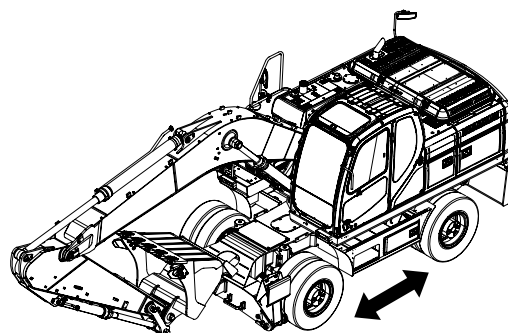

FG006786

**Figure 168**

# VENTING AND PRIMING HYDRAULIC SYSTEM

## Main System Pump

**NOTE:** *If pump is run without sufficient oil in the main hydraulic pump, damage can occur. Always vent pump of air after draining hydraulic system.*

1. With the engine stopped, remove vent plug (Figure 169) to see if any oil is present.
2. If oil is not present, fill pump with oil through port (Figure 169).
3. Install vent plug (Figure 169) first.
4. Start engine and run it for several minutes at low idle engine speed. This will pressurize the hydraulic oil tank and system.
5. Slowly loosen vent plug (Figure 169) several turns, until hydraulic oil flows out of plug. This shows that air has been released.
6. Tighten the plug (Figure 169).

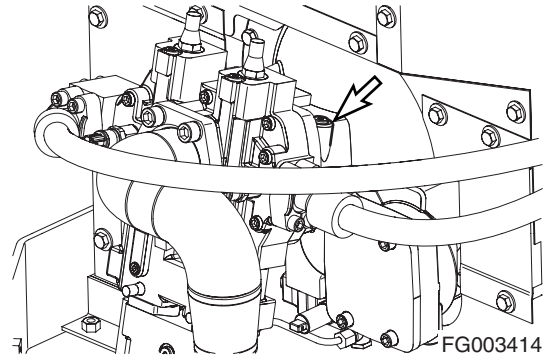

**Figure 169**

## Hydraulic Cylinders

---

### IMPORTANT

---

**If cylinders are operated in high idle after the hydraulic system has been drained or the cylinder has been rebuilt, damage to piston packing and seals may occur. Always vent air from cylinders at low idle and at a slow speed.**

---

1. Run engine at low idle. Extend and retract each cylinder to within 100 mm (4 in) of fully stroking it 4 - 5 times.
2. Operate fully extend and retract each cylinder 3- 4 times.
3. Repeat procedure until cylinders extend and retract smoothly.

## Swing Motor

---

### IMPORTANT

---

If the air is not vented from the system, it will cause damage to the swing motor and bearings.

---

**NOTE:** Perform this only when oil has been drained from swing motor.

1. Shut down engine.
2. Disconnect drain hose and fill swing motor case with hydraulic oil.
3. Connect the drain hose.
4. Start engine and set throttle at "LOW IDLE" and swing upper structure slowly two full revolutions to the left and right.

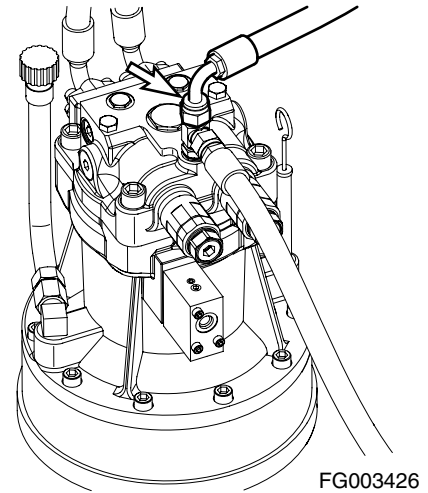

Figure 170

## Air Ejection of Transmission

---

### IMPORTANT

---

Use a transparent vinyl hose for air ejection.

---

1. Run the engine at low rpm.
2. Shift the driving speed switch to the 3rd gear of high speed.
3. Open breeders A and B for about 20 seconds at the same time.
4. Close both breeders.
5. Shift the driving speed switch to the 2nd gear of low speed.
6. Open breeder B for about 20 seconds. Do not open breeder C.
7. Close breeder B.
8. Repeat steps 2 through 7 until hydraulic oil contains no bubble which means that air is ejected completely. If hydraulic still contains bubbles, repeat steps 2 through 7.

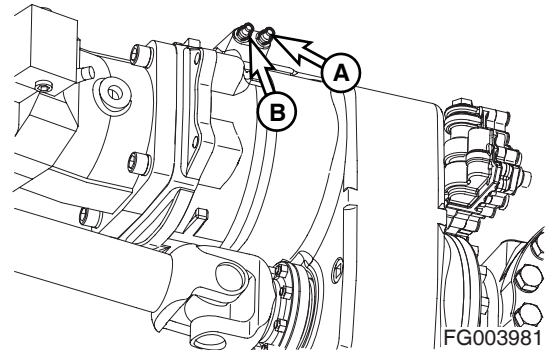

Figure 171

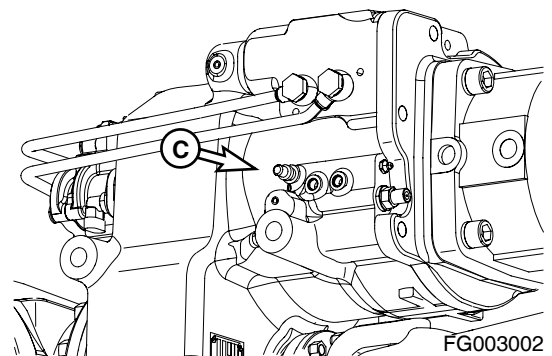

Figure 172

## Air Ejection of Brake Line

---

### IMPORTANT

---

Use a transparent vinyl hose for air ejection.

Do not push the brake pedal fully after opening the breeder.

---

1. Run the engine at low rpm.
2. Open the brake breeder at axle.
3. Push the brake pedal slowly to drain hydraulic oil.
4. Close the breeder.
5. Repeat steps 2 through 4 until hydraulic oil contains no bubble which means that air is ejected completely. If hydraulic still contains bubbles, repeat steps 2 through 4.
6. Use the same steps to eject air of other brake lines.

### General Venting

1. After venting air from all components, shut the engine down and check the hydraulic oil level. Fill hydraulic oil tank to "H" mark on sight gauge.
2. Start engine and operate all controls again, run engine for five minutes to ensure all systems have been vent and purged of air. Set engine speed to "LOW IDLE," and check hydraulic oil level again. Add oil as necessary.
3. Check for oil leaks and clean all fill and venting locations.

Front Axle

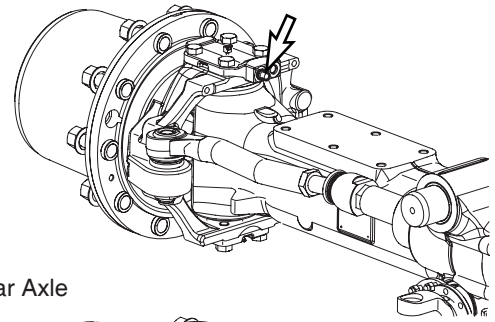

Rear Axle

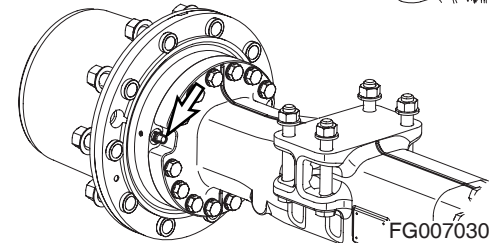

Figure 173

# MAINTENANCE IN SPECIAL CONDITIONS

Conditions	Maintenance Required
Operating in mud, water or rain.	Perform a walk around inspection to check for any loose fittings, obvious damage to the machine or any fluid leakage.
	After completing operations, clean mud, rocks or debris from the machine. Inspect for damage, cracked welds or loosened parts.
	Perform all daily lubrication and service.
	If the operations were in salt water or other corrosive materials, make sure to flush the affected equipment with fresh water.
Operating in an extremely dusty or hot environment.	Clean the air intake filters on a more frequent basis.
	Clean the radiator and oil cooler fins to remove embedded dirt and dust.
	Clean the fuel system intake strainer and fuel filter more frequently.
	Inspect and clean as required the starter and alternator.
Operating in rocky terrain.	Check the undercarriage and track assemblies for damage or excessive wear.
	Inspect for loose or damaged fittings or bolts.
	Relax track tension.
	On a more frequent basis, inspect the front end attachments for damage or excessive wear.
	Install a top guard and front guard as required for protection against falling rock.
Operating in extreme cold.	Use the proper fuel for the temperature conditions.
	Using a hydrometer, check the antifreeze to make sure that it is providing the proper cold weather freeze protection.
	Verify the condition of the batteries. In extremely cold weather remove the batteries at night and store them in a warmer area.
	Remove mud buildup as soon as possible to prevent it from freezing to the undercarriage and causing damage.

# LONG TERM STORAGE

Perform the following if storing the excavator for more than one month.

Conditions	Maintenance Required
Cleaning	Pressure wash the undercarriage and track assemblies. Inspect for damage or loose or missing parts.
Lubrication	Perform all daily lubrication procedures.
	Apply a coating of light oil to the exposed plated metal surfaces, such as hydraulic cylinder rods, etc.
	Apply a coating of light oil to all of the control linkages and control cylinders (control valve spools, etc.).
Battery	Remove the battery from the excavator or remove the battery leads from the battery to fully charge and store.
Cooling System	Inspect the coolant recovery tank to make sure that the antifreeze level in the system is at the correct level.
	Every 90 days, use a hydrometer to measure the protection level of the coolant. Refer to the antifreeze/coolant protection chart to determine the amount of protection the cooling system requires. Add coolant as required.
Hydraulic System	Once a month, start the engine and follow the "Hydraulic Oil Warm-up" procedures listed in this manual.



# Transportation

Obey all local, state or federal regulations for the transportation of the excavator. If unsure of regulations check with local authorities.

Check the intended route for road width, overhead clearances, weight restrictions, and traffic control regulations. Special approval or permits may be required.

---

## DANGER!

---

**DOOSAN** warns any user, that the removal of the counterweight from the machine, front attachment or any other part, may affect the stability of the machine. This could cause unexpected movement, resulting in death or serious injuries. **DOOSAN** is not liable for any misuse.

Never remove the counterweight or front attachment unless the upper structure is in-line with the lower structure.

Never rotate the upper structure once the counterweight or front attachment has been removed.

---



---

## WARNING!

---

1. Loading or unloading the machine can be a dangerous operation. Make sure to run the engine at the lowest speed setting, and travel at the slowest speed possible.
  2. Make sure that the ramp being used is capable of handling the weight of the machine. If required, add blocking under the ramp for additional support.
  3. Make sure that the ramp surface is free of grease or mud that could cause the machine to slip or slide.
  4. Make sure that the trailer is parked on firm, level ground before attempting to load/ unload the excavator.
  5. If required to turn the machine while it is on the trailer, make sure to do this at the slowest engine and travel speeds possible.
  6. Make sure that the swing lock pin is inserted before transporting to prevent the machine from accidental swinging.
  7. Make sure to secure the excavator onto the trailer as required by local transportation laws.
- 

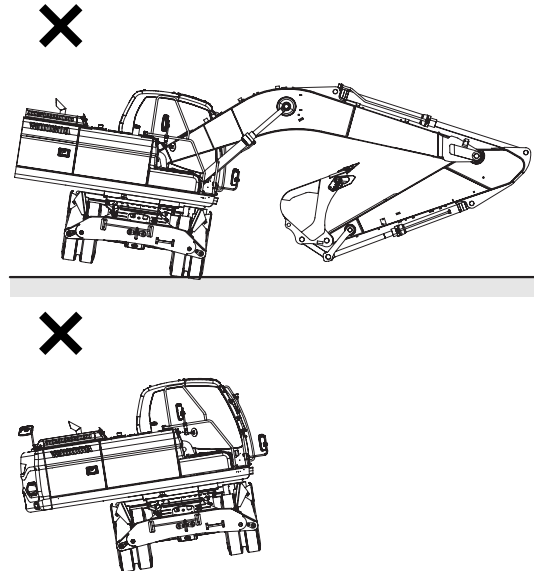

Figure 1

FG008674

# SHORT DISTANCE SELF-POWERED TRAVEL

1. Follow the Travel Instructions in Section 3 of this manual.
2. Make sure to engage the Swing Lock pin to secure the upper frame assembly before traveling more than a very short distance. (See “Swing Lock Pin and Mechanism” on page 2-76.)
3. If you have to travel across a bridge, make sure that its capacity is rated for the weight of the machine and that it is wide enough. Add extra bracing as required.

# TRAILER LOADING/UNLOADING PROCEDURES

1. Make sure that the trailer is parked on a firm and level surface. (See Figure 2.)
2. Make sure that the ramps that are being used are designed to handle the weight of the excavator. If required, add blocking under the ramp to provide additional support.
3. The ramp angle should not exceed a 15° grade. Ramps steeper than this may cause a problem when loading or unloading.

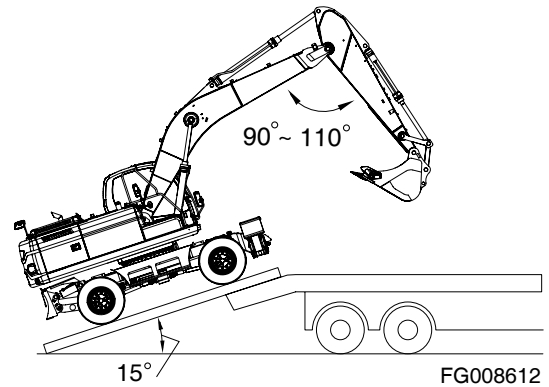

Figure 2

FG008612

4. Set the travel speed selector switch to "I" position and step on the accelerator pedal slowly.

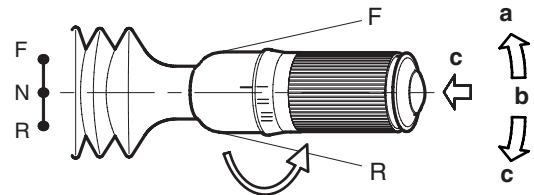

Figure 3

FG002185

5. The unit does not require disassembly for normal over the road transportation. If the boom and arm need to be removed, the counterweight will place more weight to the rear of the machine. Make sure to back the excavator onto the trailer so that the counterweight end of the excavator is positioned on the ramp first. (Figure 5)

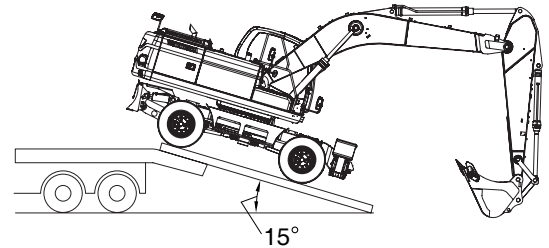

Figure 4

FG008675

6. Store the front attachment in the "Transport position" and set the Function Lock in the "TRANSPORT" position. (See Figure 6~Figure 8.)

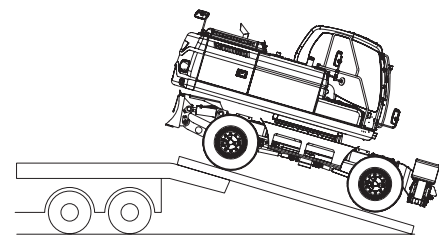
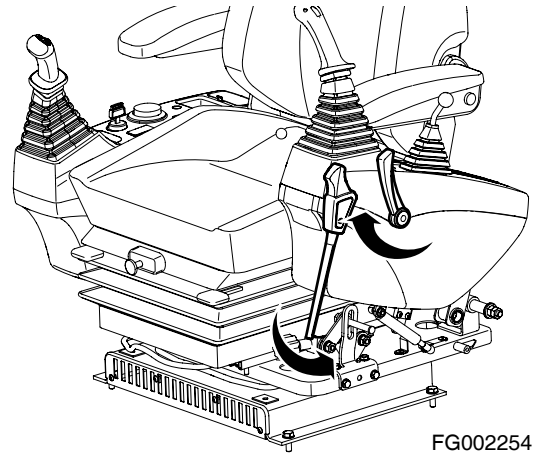

Figure 5

FG008676

7. Set safety lever and stand on "LOCK" position. Set parking brake switch to the "I" position and ram Cylinder toggle switch in the "LOCK" position.



**Figure 6**

FG002254

8. Shut down engine by turning key to "O"(OFF) position (Figure 5).
9. Remove key from starter switch.

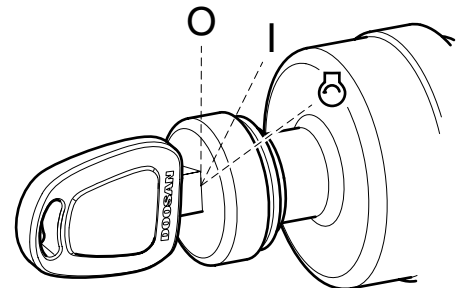

**Figure 7**

FG000175

10. Before transporting the excavator, make sure that the swing lock pin has been engaged. (See "Swing Lock Pin and Mechanism" on page 2-76.) This will prevent the excavator from accidentally rotating during transportation.
11. Make sure to secure the excavator onto the trailer before transporting. Use chains or cable tie-downs as required by local transportation laws. Use the wheel chocks supplied with the machine to secure machine. (See "Wheel Chocks" on page 2-76.)

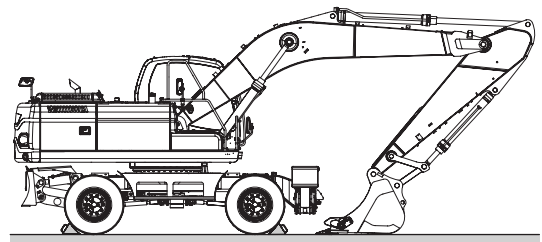

**Figure 8**

FG008670

12. Refer to the Dimensions for Transportation table for overall machine height and width measurements. (See Figure 8.) Make sure to position the excavator as shown. If not transported in this position, the height measurements may be different.

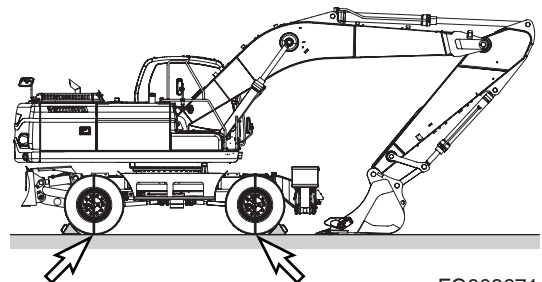

**Figure 9**

FG008671

# Troubleshooting

In all cases if a system malfunction is discovered, measures must be taken to correct the problem and the cause. Check for the cause of the problem and take preventive measures in advance through proper maintenance and repair. Since the cause of a problem at times may be due to multiple malfunctions a systematic approach must be taken to correct the problem. If a problem occurs, use the following troubleshooting table to isolate the cause and take necessary measure(s) for adjustment and repair. If the cause of the problem cannot be isolated, consult with your nearest *DOOSAN* service center for assistance. Never attempt to perform an adjustment, disassembly or repair on hydraulic, electric and electronic systems without first contacting your service center.

## ENGINE

Problem	Cause	Remedy
Starter does not operate	Low battery power.	Charge battery.
	Poor terminal contact.	Clean and tighten connections.
	Starter switch failure.	Replace switch.
	Starter relay failure.	Replace relay.
	Starter control failure.	Replace controller.
	Wiring harness faulty.	Replace harness.
	Battery relay failure.	Replace relay.
	Blown fuse.	Replace fuse.
Starter engages, engine does not start	Fuel gelled due to cold weather.	Replace fuel.
	Fuel filters clogged.	Replace filters.
	Water or dirt in fuel system.	Clean system and add new fuel.
	Air in fuel system.	Purge air from system.
	Engine stop control failure.	Contact your <i>DOOSAN</i> dealer.
	Engine stop relay failure.	Replace relay.
	Blown fuse.	Replace fuse.

<b>Problem</b>	<b>Cause</b>	<b>Remedy</b>
Engine starts, runs only at low speed or shuts down.	Engine oil viscosity incorrect.	Change oil.
	Clogged or dirty fuel injectors.	Clean injectors.
	Fuel filters clogged.	Replace filters.
Engine knocks, runs unevenly or surges.	Low engine oil.	Refill.
	Clogged air intake system.	Clean system and replace filter.
	Injection pump out of adjustment.	Contact your <i>DOOSAN</i> dealer.
	Clogged fuel filter.	Replace fuel filter.
	Water or dirt in fuel system.	Clean system and add new fuel.
	Clogged or dirty fuel injectors.	Clean injectors.
Engine has poor power	Clogged air intake system.	Clean system and replace filter.
	Clogged or dirty fuel injectors.	Clean injectors.
	Fuel filters clogged.	Replace filters.
	Engine speed control cable out of adjustment.	Readjust.
	Injection pump out of adjustment.	Contact your <i>DOOSAN</i> dealer.
	Valve backlash faulty.	Adjust backlash.
Engine runs hot	Low coolant level.	Add coolant.
	Thermostat faulty.	Replace thermostat.
	Radiator cap faulty.	Replace radiator cap.
	Radiator core plugged.	Clean radiator.
	Oil cooler core plugged.	Clean oil cooler.
	Fan belt loose or damaged.	Tighten or replace as required.
	Temperature sensor faulty.	Replace sensor.

# HYDRAULIC SYSTEM

Problem	Cause	Remedy
None of the controls function (loud noise from pumps)	Hydraulic pump failure.	Contact your <i>DOOSAN</i> dealer.
	Low hydraulic oil level.	Add hydraulic oil as required.
	Suction line clogged or damaged.	Clean or replace as required.
None of the controls function (no noise from pumps)	Pilot pump failure.	Contact your <i>DOOSAN</i> dealer.
	Cut off solenoid valve failure.	Replace solenoid.
	Safety limit switch is "ON."	Adjust limit switch clearance.
	"WORK/TRAVEL" selector switch is "TRAVEL" mode.	Select "Work Mode"
All actuators have low power	Low hydraulic oil level.	Add hydraulic oil as required.
	Suction filter clogged.	Clean filter.
	Hydraulic pumps faulty.	Contact your <i>DOOSAN</i> dealer.
	Main relief pressure too low.	Contact your <i>DOOSAN</i> dealer.
	Hydraulic pumps excavating.	Bleed air from hydraulic pumps.
Only one or two actions have little or no power	Overload relief pressure too low.	Reset pressure.
	Makeup check valve leaking.	Clean or replace as required.
	Control valve spool faulty.	Replace valve spool.
	Dirt in valve spool.	Clean or replace as required.
	Actuator failure.	Repair or replace as required.
	Cylinder seal failure.	Repair or replace as required.
	Cylinder rod damaged.	Repair or replace as required.
	Remote control valve failure.	Replace control valve.
	Wrong pilot line connection.	Reconnect pilot lines.
Oil temperature too high	Oil cooler faulty.	Contact your <i>DOOSAN</i> dealer.
	Fan belt loose.	Tighten fan belting as required.

# SWING SYSTEM

Problem	Cause	Remedy
No swinging motion	Swing brake valve faulty.	Replace brake valve.
	Hydraulic timer faulty.	Replace timer.
	Low brake release pressure.	Adjust pressures.
	Swing motor failed.	Replace swing motor.
	Remote control valve failed.	Replace control valve.
	Wrong pilot line connection.	Reconnect pilot lines.
Swing motion jerky	Swing gear worn.	Replace swing gear.
	Swing bearing damaged.	Replace bearing.
	Improper lubrication.	Add grease.

# ELECTRICAL SYSTEM

Problem	Cause	Remedy
Battery will not hold a charge	Low battery power.	Replace batteries.
	Alternator belt loose or bad.	Tighten or replace belt.
	Loose or corroded terminals.	Tighten or replace as required.
	Alternator faulty.	Repair or replace as required.
Low battery power	Internal battery short.	Replace battery.
	Short circuit in wiring.	Repair as required.
Engine speed is not controllable	Speed control dial failure.	Replace control dial.
	Throttle controller failure.	Replace controller.
	Speed control motor failure.	Repair or replace as required.
	Blown fuse.	Replace fuse.
	Wiring harness damaged.	Repair or replace as required.
	Connector failure.	Repair or replace as required.
Power mode selector does not work	Blown fuse.	Replace fuse.
	Instrument panel failed.	Replace instrument panel.
	Connector failure.	Replace connector.
	Wiring harness damaged.	Repair or replace as required.
	e-EPOS controller failure.	Repair or replace as required

<b>Problem</b>	<b>Cause</b>	<b>Remedy</b>
Working mode selector does not work	Blown fuse.	Replace fuse.
	Connector failure.	Replace connector.
	Wiring harness damaged.	Repair or replace as required.
	e-EPOS controller failure.	Replace as required.

## TRAVEL SYSTEM

<b>Problem</b>	<b>Cause</b>	<b>Remedy</b>
Travel motion does not function	Axle failure	Repair
	Activate the emergency actuation	Deactivate the emergency actuation
	Electric accelerator pedal failure	Repair or exchange
	Transmission control valve failure	Repair or exchange
	Transmission failure	Repair
	Center joint leaking	Repair or exchange
	Brake will not release	Repair
	Travel motor failure	Repair
	Hydraulic accelerator valve failure	Repair
	Wrong pilot line connection	Repair
	Transmission control pressure set too low	Repair
	Forward, reverse solenoid valve failure	Repair or exchange
Travel speed is too low	Control valve set pressure too low	Reset
	Travel motor relief set pressure low	Reset
	Brake is slightly engaged	Repair
Noise from transmission	Low gear oil	Refill
	Deterioration of gear oil	Replace
	Internal parts worn	Repair or exchange
	Gear or bearing damaged	Repair or exchange

<b>Problem</b>	<b>Cause</b>	<b>Remedy</b>
Gear will not change	Bent or unbalanced drive shaft	Repair or exchange
	Loose universal joint	Tighten
	Substantial wear of spline	Exchange
	Spider bearing worn	Exchange
	Lack of grease	Lubricate
Noise from axle	Excessive gear wear	Exchange
	Damage to gear	Exchange
	Lack of gear oil	Refill
	Deterioration of gear oil	Replace
	Worn bearing	Exchange
	Rattling at shaft spline	Exchange
Cruise control not functioning	Cruise switch failure	Repair
	Cruise solenoid valve failure	Repair or exchange
	Electric system damage	Repair
Cruise control will not release when brake pedal is pressed	Stop light pressure switch failure	Repair or exchange
	Cruise solenoid valve failure	Repair or exchange
	Electric system damage	Repair

## STEERING

<b>Problem</b>	<b>Cause</b>	<b>Remedy</b>
Steering wheel difficult to turn	Steering pump failure	Repair or exchange
	Steering priority valve failure	Repair or exchange
	Steering valve failure	Repair or exchange
	Steering cylinder failure	Repair or exchange
	Relief valve set pressure low	Reset
	Tire air pressure low	Adjust
Vibration of steering wheel	Rattling of hub bearing	Repair or exchange
	Wheel misalignment	Adjust
	King pin parts worn	Exchange
	Unbalanced right and left tires	Adjust or exchange

# BRAKES

<b>Problem</b>	<b>Cause</b>	<b>Remedy</b>
Brakes not working	Brake pressure is too low	Repair or exchange
	Brake pump failure	Repair or exchange
	Brake disks worn	Exchange or adjust clearance
	Burned out brake disks	Exchange
	Accumulator gas leaking	Refill N <sub>2</sub> gas or exchange
	Air in brake lines	Bleed air
	Brake oil leakage	Repair
Brakes dragging	Burned out brake disks	Exchange
	Broken or weak brake return springs	Exchange
Noise when brakes are applied	Lack of gear oil in hub	Refill
	Deterioration of gear oil in hub	Exchange



# Specification

## SPECIFICATION

### One-Piece Boom (5.2 m Boom, 2.6 m Arm, Front Dozer, Rear Outrigger)

Component				Specification	
				Metric	English
Equipment Weight				18.8 metric tons	20.7 tons
Bucket	CECE			0.70 m <sup>3</sup>	0.92 yd <sup>3</sup>
	PCSA			0.80 m <sup>3</sup>	1.05 yd <sup>3</sup>
Engine	Model			DL06	
	Type			Water Cooled - 6 Cylinders	
	Rated Output			158 ps @ 1,900 rpm	158 ps @ 1,900 rpm
	Maximum Torque			70 kg·m @ 1,400 rpm	506 ft lb @ 1,400 rpm
	Fuel Tank Capacity			310 liters	81.9 U.S. gal.
Hydraulic Pump	Type			Axial Piston	
	Discharging Pressure			350 kg/cm <sup>2</sup>	5,000 psi
	Maximum Discharge Quantity			2 x 200 liters/min	2 x 52.8 U.S. gpm
	Hydraulic Oil Capacity	Tank Level		116 liters	30.6 U.S. gal.
System		205 liters	54.2 U.S. gal.		
Performance	Travel Speed	Froward	Creep (I)	0 ~ 3.7 km/h	0 ~ 2.3 MPH
			Low (II)	0 ~ 9.2 km/h	0 ~ 5.7 MPH
			High (III)	0 ~ 36.9 km/h	0 ~ 22.9 MPH
		Reverse	Creep (I)	0 ~ 3.7 km/h	0 ~ 2.3 MPH
			Low (II)	0 ~ 9.2 km/h	0 ~ 5.7 MPH
			High (III)	0 ~ 36.9 km/h	0 ~ 22.9 MPH
	Digging Capability	Bucket		12.4 metric tons	13.7 tons
		Arm		8.9 metric tons	9.8 tons
	Swing Speed			10.9 rpm	
	Gradeability			35° (70% Slope)	
Minimum Swing Radius			7.0 m	23'	
Travel System	Drive System			Hydraulic Drive / Forward, Reverse 3 Speed	
	Tire Size			10.00 - 20 - 14PR	
	Brake Type			Full Hydraulic Wet Disk Brake Type	

**Two-Piece Boom (5.36 m Boom, 2.6 m Arm, Front Dozer, Rear Outrigger)**

Component				Specification	
				Metric	English
Equipment Weight				19.3 metric tons	21.3 tons
Bucket	CECE			0.70 m <sup>3</sup>	0.92 yd <sup>3</sup>
	PCSA			0.80 m <sup>3</sup>	1.05 yd <sup>3</sup>
Engine	Model			DL06	
	Type			Water Cooled - 6 Cylinders	
	Rated Output			158 ps @ 1,900 rpm	158 ps @ 1,900 rpm
	Maximum Torque			70 kg·m @ 1,400 rpm	506 ft lb @ 1,400 rpm
	Fuel Tank Capacity			310 liters	81.9 U.S. gal.
Hydraulic Pump	Type			Axial Piston	
	Discharging Pressure			350 kg/cm <sup>2</sup>	5,000 psi
	Maximum Discharge Quantity			2 x 200 liters/min	2 x 52.8 U.S. gpm
	Hydraulic Oil Capacity	Tank Level		116 liters	30.6 U.S. gal.
System		205 liters	54.2 U.S. gal.		
Performance	Travel Speed	Foward	Creep (I)	0 ~ 3.7 km/h	0 ~ 2.3 MPH
			Low (II)	0 ~ 9.2 km/h	0 ~ 5.7 MPH
			High (III)	0 ~ 36.9 km/h	0 ~ 22.9 MPH
		Reverse	Creep (I)	0 ~ 3.7 km/h	0 ~ 2.3 MPH
			Low (II)	0 ~ 9.2 km/h	0 ~ 5.7 MPH
			High (III)	0 ~ 36.9 km/h	0 ~ 22.9 MPH
	Digging Capability	Bucket		12.4 metric tons	13.7 tons
		Arm		8.9 metric tons	9.8 tons
	Swing Speed			10.9 rpm	
	Gradeability			35° (00% Slope)	
Minimum Swing Radius			7.0 m	23'	
Travel System	Drive System			Hydraulic Drive / Forward, Reverse 3 Speed	
	Tire Size			10.00 - 20 - 14PR	
	Brake Type			Full Hydraulic Wet Disk Brake Type	

# OVERALL DIMENSIONS

## One-Piece Boom

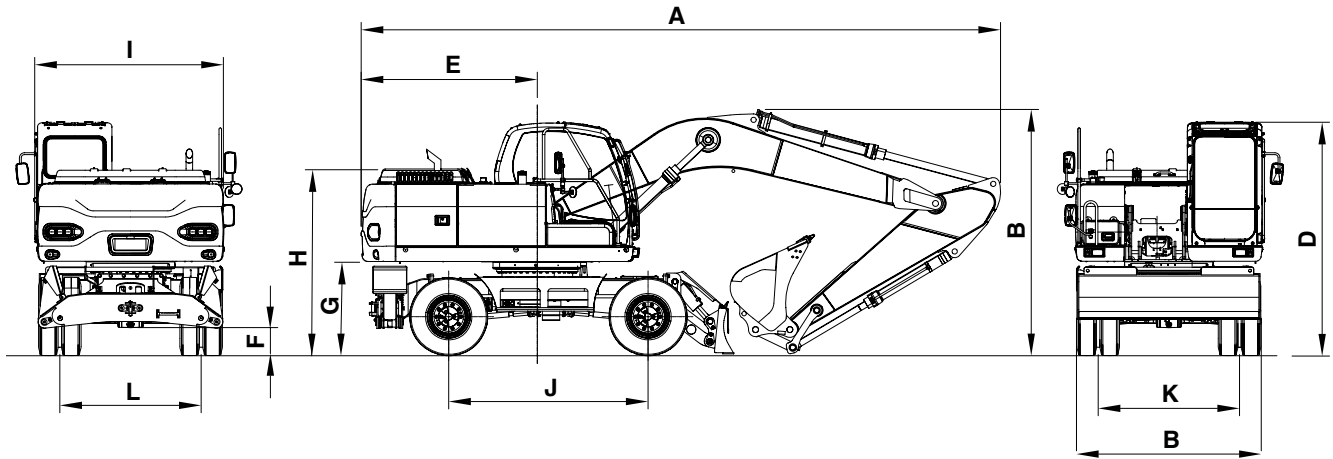

FG008699

Figure 1

Reference	Description	Dimension					
		5.2 m (17' 1") One-Piece Boom					
		2.2 m (7' 3") Arm		2.6 m (8' 6") Arm		3.1 m (10' 2") Arm	
A	Shipping Length	8,715 mm	28' 7"	8,659 mm	28' 5"	8,507 mm	27' 10"
B	Shipping Width	2,496 mm	8' 2"	2,496 mm	8' 2"	2,496 mm	8' 2"
C	Shipping Height (Boom)	3,212 mm	10' 6"	3,310 mm	10' 1"	3,772 mm	12' 5"
D	Height Over Cab	3,135 mm	10' 3"	3,135 mm	10' 3"	3,135 mm	10' 3"
E	Counter Weight Swing Clearance	2,450 mm	8'	2,450 mm	8'	2,450 mm	8'
F	Ground Clearance	350 mm	1' 1"	350 mm	1' 1"	350 mm	1' 1"
G	CounterWeight Clearance	1,249 mm	4' 1"	1,249 mm	4' 1"	1,249 mm	4' 1"
H	Engine Cover Height	2,530 mm	8' 3"	2,530 mm	8' 3"	2,530 mm	8' 3"
I	Upper Housing Width	2,494 mm	8' 2"	2,494 mm	8' 2"	2,494 mm	8' 2"
J	Wheel Base	2,700 mm	8' 10"	2,700 mm	8' 10"	2,700 mm	8' 10"
K,L	Tread Width	1,944 mm	6' 5"	1,944 mm	6' 5"	1,944 mm	6' 5"

## Two-Piece Boom

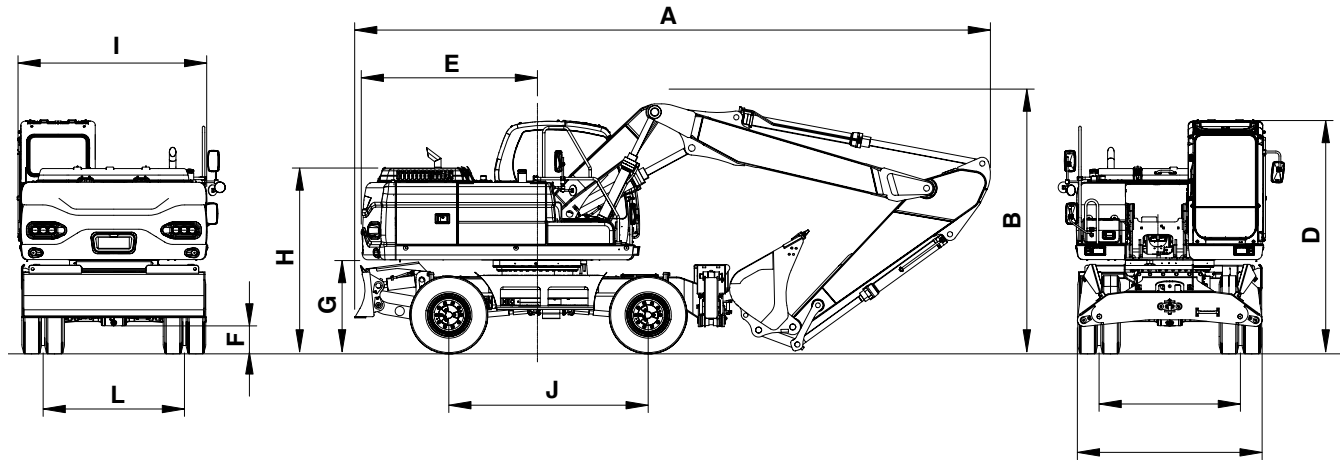

FG008700

Figure 2

Reference	Description	Dimension			
		5.36 m (17' 7") Two-Piece Boom			
		2.3 m (7' 7") Arm		2.6 m (8' 6") Arm	
A	Shipping Length	8,860 mm	29' 1"	8,610 mm	28' 3"
B	Shipping Width	2,496 mm	8' 2"	2,496 mm	8' 2"
C	Shipping Height (Boom)	3,140 mm	10' 4"	3,360 mm	11'
D	Height Over Cab	3,135 mm	10' 3"	3,135 mm	10' 3"
E	Counter Weight Swing Clearance	2,450 mm	8'	2,450 mm	8'
F	Ground Clearance	350 mm	1' 1"	350 mm	1' 1"
G	CounterWeight Clearance	1,249 mm	4' 1"	1,249 mm	4' 1"
H	Engine Cover Height	2,530 mm	8' 3"	2,530 mm	8' 3"
I	Upper Housing Width	2,494 mm	8' 2"	2,494 mm	8' 2"
J	Wheel Base	2,700 mm	8' 10"	2,700 mm	8' 10"
K,L	Tread Width	1,944 mm	6' 5"	1,944 mm	6' 5"

# WORKING RANGE

## One-Piece Boom

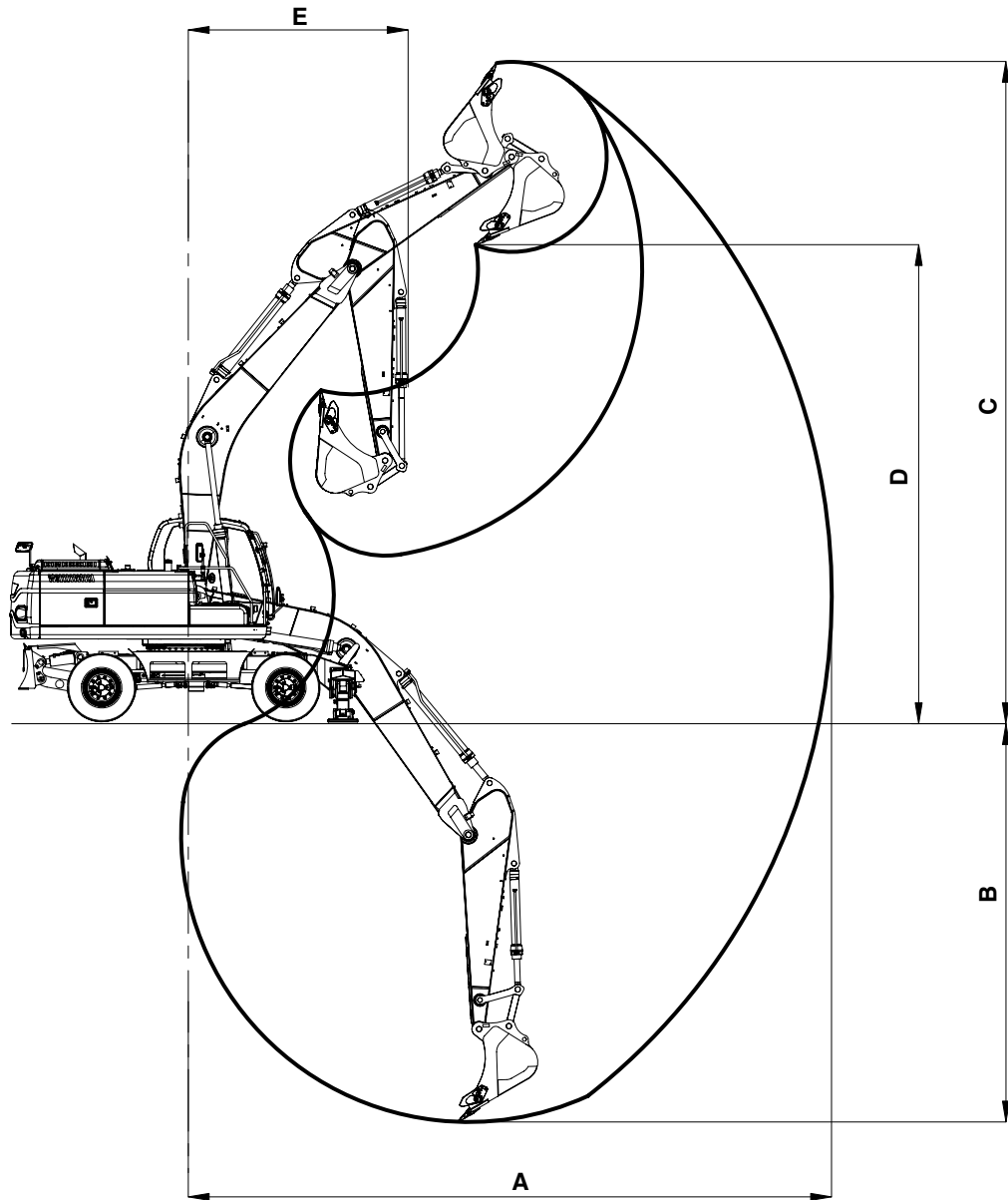

FG008672

Figure 3

Reference	Description	Dimension					
		5.2 m (17' 1") One-Piece Boom					
		2.2 m (7' 3") Arm		2.6 m (8' 6") Arm		3.1 m (10' 2") Arm	
A	Max. Digging Reach	8,830 mm	28' 11"	9,200 mm	30' 2"	9,560 mm	31' 4"
B	Max. Digging Depth	5,560 mm	18' 3"	5,965 mm	19' 7"	6,465 mm	21' 3"
C	Max. Digging Height	9,115 mm	29' 11"	9,340 mm	30' 8"	9,270 mm	30' 5"
D	Max. Dump Height	6,420 mm	21' 1"	6,650 mm	22'	6,645 mm	22'
E	Min. Swing Radius	3,195 mm	10' 6"	3,200 mm	10' 6"	3,185 mm	10' 5"

## Two-Piece Boom

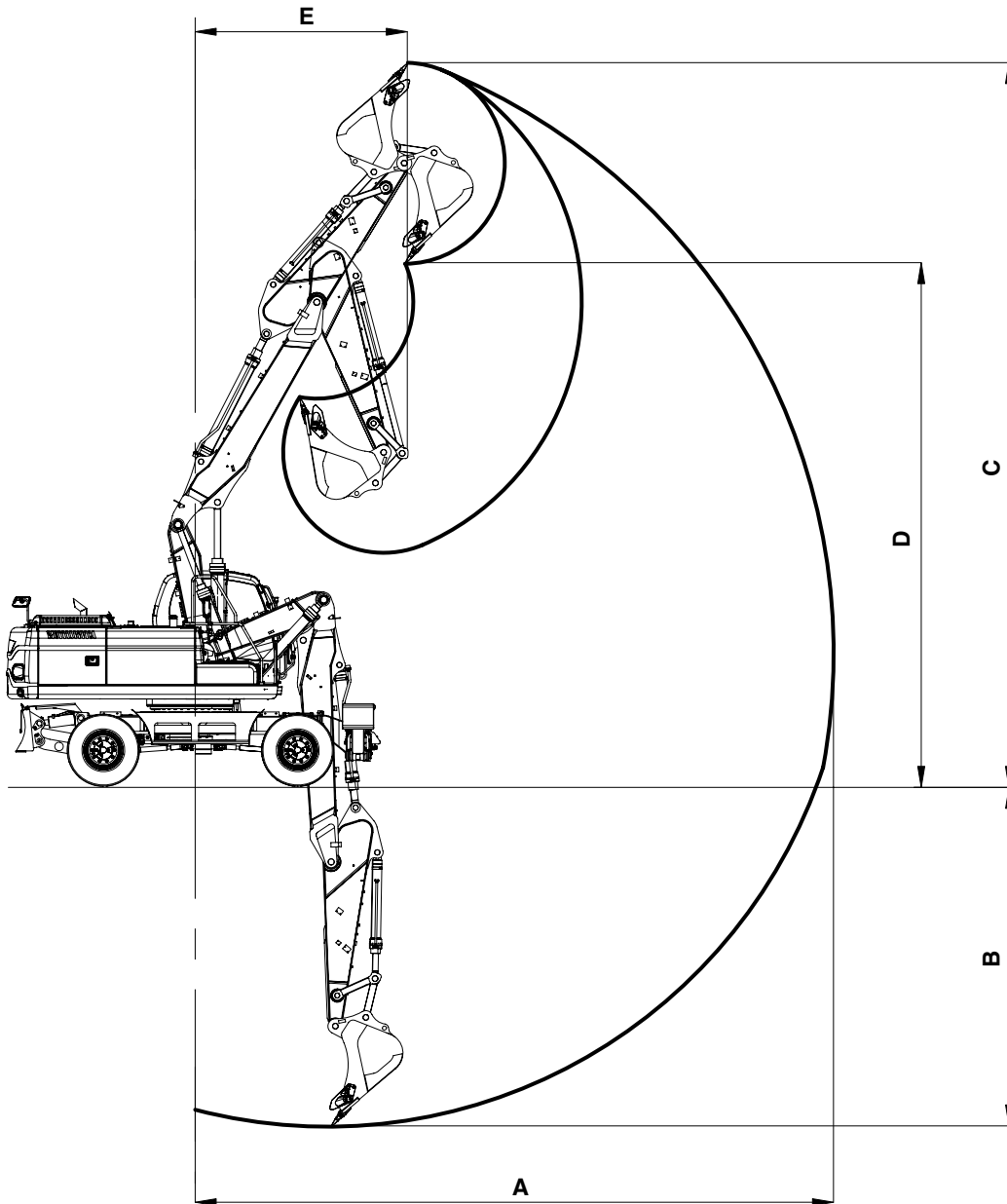

Figure 4

FG008673

Reference	Description	Dimension			
		5.36 m (17' 7") Two-Piece Boom			
		2.3 m (7' 7") Arm		2.6 m (8' 6") Arm	
A	Max. Digging Reach	9,230 mm	30' 3"	9,530 mm	31' 3"
B	Max. Digging Depth	5,600 mm	18' 4"	5,900 mm	19' 4"
C	Max. Digging Height	10,260 mm	33' 8"	10,510 mm	34' 6"
D	Max. Dump Height	7,415 mm	24' 4"	7,660 mm	25' 2"
E	Min. Swing Radius	2,965 mm	9' 9"	3,160 mm	10' 4"

# INDEX

## Numerics

- 1,000 Hour / 6 Month Service 4-46
- 10 Hour / Daily Service 4-15
- 12,000 Hour / Six Year Service 4-62
- 2,000 Hour / Yearly Service 4-53
- 250 Hour Service 4-29
- 4,000 Hour / Biennial Service 4-61
- 50 Hour / Weekly Service 4-25
- 500 Hour / 3 Month Service 4-35

## A

- Abnormal State Warning Symbols 2-34
- Accelerator Pedal 3-24
- Adjust Valve Clearance 4-60
- Adjusting the Pump Flow 3-43
- Air Ejection of Break Line 4-93
- Air Ejection of Transmission 4-92
- Air Intake System 4-23
  - Outer Element of Air Cleaner 4-41
  - Replace Outer Air Cleaner Element 4-54
- Alternator and Starter 4-60
- Antifreeze Concentration Tables 4-80
- Antivibration Shock Mounts 4-60
- Ashtray 2-71
- Audio Control Panel 2-12
- Auto Idle Mode 3-26
- Auto Idle Selector Button 2-39
- Auxiliary Mode Switch 2-11

## B

- Battery 4-75
  - Box Door 2-74
  - Electrolyte Level 4-76
  - Terminals 4-76
  - Voltage 2-33
- Boom, Arm and Front Attachment Pins 4-25
- Boost Mode 3-26
- Booster Button 2-19
- Booster Cable 3-8
- Brake Accumulator 4-85
- Brakes 6-7
  - Pedal 3-24
- Breaker Selection 2-51
- Bucket 4-72
  - O-ring 4-73
  - Teeth and Side Cutters 4-22
  - Tooth 4-72

## C

- Cabin Light 2-61
- Cabin Storage Compartments 2-71
- Cabin Work Light Switch 2-15
- Ceiling Cover 2-67
- Change Breaker Filter Element (Optional) 4-33
- Charge Warning Light 2-30
- Check and Confirmation After Stopping Engine 3-13
- Cigarette Lighter 2-16
- Circuit Breaker 2-61
- Clock 2-29, 2-43
- Cold Weather Hydraulic System Warm-up 3-11
- Cold Weather Starting 3-6
- Communication
  - Error Warning 2-33
  - Indicator 2-32
- Component Locations 2-4
- Coolant Temperature Warning Light 2-30
- Cooling System
  - Clean Radiator, Oil Cooler and Air Conditioner Condenser Coil 4-39
  - Engine 4-79
  - Engine Coolant Temperature Warning Light 2-30
  - Oil Cooler Dust Net 4-21
  - Radiator Coolant 4-55
  - Refill Cooling System 4-21
- Cracks and Faulty Welds 4-23
- Cruise Control 3-22
- Cup Holder 2-73
- Cycle Time Tests 4-60

## D

- Description of Lubrication and Service Chart 4-9
- Digital Clock 2-29
- Display Selection 2-42
- Display Selector Button 2-41
- Door Side Latch 2-70
- Door Window Holder 2-73
- Down Arrow Button 2-41
- Dozer / Outrigger Selector Switch 2-18
- Dozer Cylinder Protection Cover 2-75

## E

- Electrical System 4-75, 6-4
- Engine 6-1
  - Adjust Valve Clearance 4-60

- Check and Adjust Engine 4-52
- Check Warning Light 2-31
- Coolant Temperature Gauge 2-28
- Coolant Temperature Warning Light 2-30
- Cover 2-74
- Emergency Stop Switch 2-11
- Fan Belt 4-31, 4-32
- Head Bolt Torques 4-60
- Oil and Filter 4-28, 4-36
- Oil Level 4-16
- Oil Pressure Warning Light 2-30
- Shutdown 3-12
- Speed 2-33
- Speed Control Dial 2-10
- Start 3-4
- Start and Stop 3-2
- ESC Button 2-42
- Excavator Rated Lift Capacity Tables 1-45

## F

- Fan Belt 4-28
- Filter / Oil Info 2-44
- Filter State 2-34
- Flow Control 2-49
- Flow Control Button 2-39
- Front
  - Axle Case 4-58
  - Bottom Window 2-69
  - Drive Shaft 4-40
  - Hydraulic Pump Pressure 2-34
  - Upper Windows 2-68
  - Windows 2-68

## Fuel

- Filter 4-44
- Gauge 2-27
- Heater Switch 2-17
- Level 4-18
- System 4-44
  - Transfer Pump 4-81
- Tank Drain Valve 4-28
- Transfer Pump 4-81

## Fuse

- Boxes 2-62, 4-77
- Fuses 4-76
- Fusible Link 2-62
- Identification 4-78

## G

### Gauges

- Engine Coolant Temperature Gauge 2-28
- Fuel Gauge 2-27
- Hour Meter 2-29
- Hydraulic Oil Temperature 2-28
- Multifunction Gauge 2-29, 2-32

- General Venting 4-93
- Grease Arm and Front Attachment Pins 4-29
- Grease Dozer Blade Pins 4-15
- Grease Outrigger Pins 4-15

## H

- Handling a New Excavator 3-1
- Handling of Accumulator 4-84
- Hanger 2-72, 2-73
- Hazard Warning Light 2-25
- Hazard Warning Light Switch 2-25
- Head Bolt Torques 4-60
- Heater and Air Conditioner 2-53
  - Additional Operating Instruction 2-58
  - Control Panel 2-16, 2-54
  - Filter 4-37, 4-50
  - Location of Controls and Vents 2-53
  - Memory Function of Used Mode 2-58
  - Refrigerant 4-51
  - System 4-63

- Horn Button 2-19

- Hour Meter 2-29

- Hub Reduction Gear 4-59

- Hydraulic Oil System

- Breaker Operation 3-38

- Full Flow Filter Replacement 4-33

- Hydraulic System 6-3

- Flow Control 2-49

- Front Hydraulic Pump Pressure 2-34

- General Venting 4-93

- Hydraulic Breaker

- Oil and Filter 3-42

- Hydraulic Cylinders 4-91

- Hydraulic Oil Exchange 4-56

- Hydraulic Oil Return Filter 4-47

- Hydraulic Oil Tank 4-16

- Hydraulic Oil Temperature Gauge 2-28

- Leaks in the Hydraulic System 4-18

- Main System Pump 4-91

- Oil Exchange 4-56

- Rear Hydraulic Pump Pressure 2-34

- Swing Motor 4-92

- Warm-up 3-10

## I

- Indicator

- Communication Indicator 2-32

- Indicator Lights

- Charge Warning Light 2-30

- Coolant Temperature Warning Light 2-30

- Engine Check Warning 2-31

- Engine Oil Pressure Warning Light 2-30

- Preheating Indicator Light 2-31

- Inspect All Tires for Correct Tire Pressure and Signs

of Damage or Abnormal Wear 4-15  
Inspecting Engine Before Starting 3-2  
Inspection, Maintenance and Adjustment 4-1  
Instrument Panel 2-20, 2-26

## **L**

Language 2-43  
Leaks in the Fuel System 4-19  
Leaks in the Hydraulic System 4-18  
Levers  
    Adjusting Reclining 2-64  
    Adjusting the Seat Forward 2-63  
    Adjusting the Seat's Angle 2-63  
    Angle Adjustment of Armrest 2-64  
    Safety Lever 2-20  
Lifting 3-46  
Lights  
    Cabin 2-61  
Locations of Safety Labels 1-5  
Long Term Storage 4-95  
Lubrication and filters 3-2  
Lubrication and Service Chart 4-8

## **M**

Magnetic Clutch 4-63  
Main Menu 2-40  
Maintenance in Special Conditions 4-94  
Maintenance Intervals 4-12  
Miscellaneous Access Doors 2-74  
Mode Selection 3-25  
Mode Selector Buttons 2-38  
Multifunction Gauge 2-29, 2-32

## **O**

Oil Cooler Dust Net 4-21  
Opening the Window 2-68  
Operating  
    Controls 2-1  
    Precautions 3-30  
    Techniques 3-46  
Operation 3-1  
Operation In  
    Extreme Cold 3-48  
    Extreme Heat 3-49  
    High Altitudes 3-51  
    Rainy or Humid Conditions 3-50  
    Salt Water Areas 3-51  
Operation of All Switches 4-23  
Operation Selection Display 2-51  
Operation Under Unusual Conditions 3-48  
Operational Checks Before Starting Engine 3-3  
Operational Controls and Panels 2-8  
Operator's Area 2-6  
Operator's Compartment Light 2-61

Outer Air Cleaner Element 4-54  
Outer Element of Air Cleaner 4-41  
Overall Dimensions 7-3  
Overload Alarm Selection 2-52  
Overload Warning Switch (Optional) 2-17

## **P**

Panels  
    Air Conditioner Control Panel 2-16  
    Audio Control 2-12  
    Heater and Air Conditioner 2-53  
    Heater and Air Conditioner Control Panel 2-54  
    Instrument 2-20  
    Instrument Panel 2-26  
Parking Excavator 3-35  
Password  
    Activated 2-27  
    Set Password 2-47  
Password Activated 2-27  
Photo Sensor 2-21  
Pilot Accumulator 4-84  
Pilot Cutoff Switch 2-61  
Pilot Filter 4-33, 4-48  
Power Boost Selection 2-51  
Power Mode 3-25  
Power Mode Selector Button 2-38  
Power Socket 2-16  
Preheating Light 2-31  
Preliminary Work Machine Setup for Maintenance 4-4  
Preventive Maintenance 4-1  
Pump Pressure  
    Front Pump 2-34  
    Rear Pump 2-34

## **Q**

Quick Clamp Operation Selection 2-52  
Quick Clamp Switch (Optional) 2-11

## **R**

Radiator Coolant 4-55  
Rear Axle Case 4-59  
Rear Hydraulic Pump Pressure 2-34  
Refill Cooling System 4-21  
Right Turn Signal Light 2-25  
Rotating Buttons 2-19

## **S**

Safety 1-1  
Safety Lever 2-20, 3-14  
Safety Precautions 4-3  
Seat 2-63  
Seat Adjustment

- Adjusting Reclining 2-64
- Adjusting the Seat Forward 2-63
- Adjusting the Seat's Angle 2-63
- Adjustment of Lumbar Support 2-64
- Air Suspension Seat 2-66
- Angle Adjustment of Armrest 2-64
- Headrest 2-64
- Left and Right Control Stand Location 2-65
- Left and Right Control Stand Elevation Height 2-65
- Seat Belt 2-64, 4-23
- Seat Warmer Switch (Optional) 2-18
- Selection Button 2-41
- Selection of
  - Breaker 2-51
  - Overload Alarm 2-52
  - Power Boost Selection 2-51
  - Quick Clamp Operation 2-52
  - Shear 2-51
- Self-powered Travel 5-2
- Serial Numbers 4-2
- Set Password 2-47
- Setting Clock 2-43
- Shear Buttons 2-20
- Shear Selection 2-51
- Shutdown
  - Check and Confirmation After Stopping Engine 3-13
  - Engine Shutdown 3-12
  - Parking Excavator 3-35
- Side Door 2-74
- Specification 7-1
- Standard Specification 7-1
- Starter Switch 2-10
- Starting Engine Using a Booster Battery 3-8
- Start-up
  - Cold Weather Hydraulic System Warm-up 3-11
  - Cold Weather Starting 3-6
  - Engine Start 3-4
  - Hydraulic System Warm-up 3-10
  - Inspection Before Starting Engine 3-2
  - Operational Checks Before Starting Engine 3-3
  - Starting Engine Using a Booster Battery 3-8
- Steering 6-6
  - Knuckle 4-41
  - Wheel 3-24
- Stereo 2-59
  - Audio Control Panel 2-12
- Structural Damage 4-60
- Suction Strainer 4-56
- Sun Visor 2-72
- Swing
  - Bearing 4-26
  - Gear and Pinion 4-35
  - Lock 2-76

- Motor 4-92
- Reduction Device 4-19, 4-46, 4-53
- Reduction Device Oil 4-33
- System 6-4
- Switches
  - Auto Idle Selector Button 2-39
  - Automatic Travel Speed Control 3-38
  - Auxiliary Mode 2-11
  - Booster Button 2-19
  - Cabin Work Light Switch 2-15
  - Cigar Lighter 2-16
  - Display Selector Button 2-41
  - Down Arrow Button 2-41
  - Engine Emergency Stop 2-11
  - Engine Speed Control 3-23
  - Engine Speed Control Dial 2-10
  - ESC Button 2-42
  - Flow Control Button 2-39
  - Fuel Heater 2-17
  - Horn Button 2-19
  - Overload Warning (Optional) 2-17
  - Pilot Cutoff Switch 2-61
  - Power Mode Selector Button 2-38
  - Power Socket 2-16
  - Quick Clamp (Optional) 2-11
  - Rotating Buttons 2-19
  - Seat Warmer (Optional) 2-18
  - Selection Button 2-41
  - Shear Buttons 2-20
  - Starter Switch 2-10
  - Travel Speed Selector Switch 2-14
  - Trenching Mode Selector Button 2-38
  - Up Arrow Button 2-40
  - Warning Light 2-17
  - Wiper Switch (Lower) 2-15
- Symbols
  - Air Cleaner Clogged Warning 2-36
  - Overload Warning (Optional) 2-37
  - Pilot Filter Clogged Warning 2-35
  - Return Filter Clogged Warning 2-36

**T**

- Table of Recommended Lubricants 4-6
- Tire Changing Procedure 4-87
- Tire Damage 4-86
- Tires and Wheels 4-86
- Towing Procedure 3-36
- Transmission
  - Fluid 4-58
- Transportation 5-1
- Travel 3-15
  - Problems 3-22
  - Speed Selector Switch 2-14
- Travel System 6-5

Trenching Mode Selector Button 2-38  
Troubleshooting 6-1

## **U**

Up Arrow Button 2-40

## **V**

Venting and Priming Hydraulic System 4-91  
    General Venting 4-93  
    Hydraulic Cylinders 4-91  
    Main System Pump 4-91  
    Swing Motor 4-92

## **W**

Warning Light Switch 2-17  
Water Separator 4-19  
Wheel Chocks 2-76  
Window Washer Liquid 4-22  
Windows  
    Door Window Holder 2-73  
    Front 2-68  
    Front Bottom 2-69  
    Front Upper 2-68  
    Opening 2-68  
    Sun Visor 2-72  
Wiper Switch (Lower) 2-15  
Work Mode 3-25